

**NO JOB IS SO IMPORTANT
AND NO SERVICE SO URGENT
That We Cannot Take The Time
TO PERFORM OUR WORK SAFELY**

TERMINAL SUPERINTENDENTS

I. M. COMMER..... Roseville
E. A. VOTAW..... Ogden

SR. ASST. TERMINAL SUPERINTENDENT
C. R. URBICK..... Roseville

ASST. TERMINAL SUPERINTENDENTS

B. L. CHATELAIN..... Roseville
P. E. BRISTOL..... Roseville
R. L. STUBBS..... Roseville
E. R. LAW..... Roseville
R. S. HATFIELD..... Sacramento
D. J. KOLIBABA..... Ogden
W. B. ECKHARDT..... Ogden

TRAINMASTERS

W. HEFFNER..... Roseville
T. B. BIRD..... Roseville
A. C. DAVIS..... Roseville
J. E. CODY..... Sparks
W. P. FISHER..... Carlin
H. L. McDOWELL..... Redding
H. H. MARSH..... Stockton
H. L. JOHNSON..... Tracy

ASSISTANT TRAINMASTERS

S. G. GUTIERREZ..... Roseville
R. L. PODAWILTZ..... Roseville
J. A. BIANCHINI..... Roseville
R. N. PETERSON..... Roseville
V. E. BELL..... Ogden

ROAD FOREMEN OF ENGINES

D. E. GREEN..... Roseville
R. M. RIDGEWAY..... Roseville
D. J. LEGG..... Roseville
D. J. KLOCK..... Sparks
J. A. WILLENER..... Carlin
D. R. CLOW..... Ogden
J. S. STORMENT..... Tracy

ASSISTANT ROAD FOREMAN OF ENGINES

M. J. LENZ..... Roseville

CHIEF TRAIN DISPATCHERS

C. L. KENNEDY..... Roseville
H. JAY..... Roseville

GENERAL YARDMASTERS

R. D. ERRECART..... Roseville
R. J. PENDERGAST..... Sacramento

**Southern Pacific
Transportation Company**



**SACRAMENTO
DIVISION
TIMETABLE**

8

**EFFECTIVE SUNDAY, OCTOBER 30, 1977
AT 12:01 A. M.
PACIFIC STANDARD TIME
FOR THE GOVERNMENT AND INFORMATION
OF EMPLOYEES ONLY**

R. L. KING,
Vice President - Operations
J. D. RAMSEY,
General Manager
C. T. BABERS,
W. J. LACY,
Assistant General Managers
J. J. WILLIS,
Asst. Vice President - Transportation.
J. W. BREEN,
Manager Operations Planning & Control.
L. G. SIMPSON,
Superintendent.
R. D. BREDEBERG,
H. J. KERINS,
C. H. PARKER,
Assistant Superintendents.

SACRAMENTO DIVISION TIMETABLE No. 8, OCTOBER 30, 1977

2

OGDEN SUBDIVISION

EAST-WARD	Mile Post Location	STATIONS SIDING CAPACITIES AND FACILITIES	Station Number	Distance from Ogden	WEST-WARD
FIRST CLASS					FIRST CLASS
6					5
Passenger					Passenger
Leave Daily					Arrive Daily
AM 12.57	534.5	Yd. Lmts. TO-R CARLIN (WP Conn.) BKYPQ	12129	248.6	AM 1.55
	554.3	19.8 WEST ELKO (WP Conn.)		228.8	
s 1.23	556.2	5430 TO ELKO P	12120	226.9	s 1.30
	576.7	7600 HALLECK	12112	206.4	1.06
	589.6	4650 DEETH	12109	193.5	
	591.1	1.5 WPRR Connection	12107	192.0	
2.10	603.6	12.5 ALAZON (WP Conn.) CTO	12101	179.5	12.43 AM
	607.5	E-6145 3.9 PY W-5080 WELLS DT	10190	175.6	
	616.4	E-6680 8.9 MOOR CTO	10185	166.7	
	624.6	9480 8.2 HOLBORN CTO	10180	158.5	
	632.5	9700 7.9 PEQUOP CTO	10172	150.6	
	640.6	W-9715 8.1 VALLEY PASS Double Track	10164	142.5	
	644.8	4.2 COBRE Double Track	10160	138.3	
	661.9	E-8670 Yd. Lmts. 17.1 P W-6180 MONTELLO P	10149	121.2	
	679.8	E-5830 17.9E-18.7W P W-8130 LUCIN P	10131	102.5	
	685.1	9580 5.3 PIGEON Centralized Traffic Control	10125	97.2	
	693.7	9630 8.6 JACKSON Centralized Traffic Control	10116	88.6	
	702.1	9590 8.4 P LEMAY Centralized Traffic Control	10108	80.2	
	711.1	9650 9.0 GROOME Centralized Traffic Control	10099	71.2	
	720.7	9670 9.6 HOGUP Centralized Traffic Control	10089	61.6	
	729.5	9575 8.8 STRONGKNOB Centralized Traffic Control	10078	52.8	
	734.6	5.1 P LAKESIDE Centralized Traffic Control	10072	47.7	
	739.7	5.1 TRESEND No. 1 Track	10067	42.6	
	745.2	9620 5.5 13.2 ↑ MIDLAKE No. 2 Track	10061	37.1	
	752.9	7.8 ↓ BRIDGE No. 2 Track	10053	29.4	
	755.2	2.3 SALINE Double Track	10050	27.1	
	767.2	M-6240 12.0 LITTLE MOUNTAIN Double Track	10039	15.1	
	776.3	9.1 WEST WEBER Double Track	10037	6.0	
s 6.15 AM	782.3	Yd. Lmts. TO-R OGDEN BKIYPQ	10000	0.0	9.50 PM
Arrive Daily		(247.8 Eastward) (248.6 Westward)			Leave Daily
6					5

ADDITIONAL STATIONS			
Capacity and Direction of entry into Spurs	Mile Post	NAME	Station Number
2350E ..	544.7	Moleen	12124
..	564.8	Osino	12118
..	568.4	Ryndon	12117
..	573.1	Elburz (W. P. Conn.)	12116
..	758.5	Promontory Pt.	10045
Eastward Track			
600E ..	669.3	Tecoma	10142

RULE 5. Ogden. Time applies for No. 5 and No. 6 at Amtrak passenger station and for other trains at yard limit board MP 780.21.

Time shown for eastward first class trains at Carlin and Elko for information only. See Western Pacific Railroad timetable for eastward train movements between Carlin and Alazon.

SPARKS SUBDIVISION

EAST-WARD FIRST CLASS 6 Passenger Leave Daily	Mile Post Location	STATIONS SIDING CAPACITIES AND FACILITIES		Station Number	Distance from Carlin	WEST-WARD FIRST CLASS 5 Passenger Arrive Daily
		Yd. Lmts. TO-R	BKYPQ			
PM 8.34	246.2	SPARKS		16105	288.3	AM 6.37
	249.1	VISTA	P	16055	285.4	6.21
	253.1	5990 HAFED	P	16049	281.4	
	257.3	5875 PATRICK	P	16043	277.2	
	262.1	5745 CLARK	P	16035	272.4	
	266.2	9600 THISBE	P	16030	268.3	
	276.1	10100 FERNLEY	YPQ	16020	258.4	
	284.5	9400 DARWIN	P	16010	250.0	
	288.1	6500 HAZEN	P	14160	246.4	
	292.5	6185 MASSIE		14157	242.0	
	302.0	10700 UPSAL		14148	232.5	
	311.7	9600 PARRAN		14137	222.8	
	320.0	9860 OCALA		14129	214.5	
	328.4	9670 TOY		14121	206.1	
	336.8	9940 GRANITE POINT		14110	197.7	
	340.5	PERTH		14090	194.0	
	344.3	W-6450 E-6075 LOVELOCK	P	14082	190.2	
	357.8	OREANA		14067	176.7	
	366.0	M-6200 RYE PATCH		14059	168.5	
	377.0	HUMBOLDT		14048	157.3	
	384.1	IMLAY		14041	150.2	
	388.7	MILL CITY		14035	145.6	
	397.0	COSGRAVE		14027	137.3	
	406.6	ROSE CREEK		14016	127.7	
	406.8					
S 11.11 PM 11.14	417.3	6756 WINNEMUCCA	PQ	14005	117.2	S 3.55
	420.9	WESO (WP Conn.)	IP	12198	113.6	3.48
	422.8	TULE		12194	111.7	
	439.3	PREBLE		12185	95.2	
	448.1	6050 IRON POINT		12180	86.4	3.24
	466.3	7550 MOTE		12171	68.2	3.08
	475.8	6500 TO BATTLE MOUNTAIN	PQ	12162	58.7	3.00
	492.9	7580 MOSEL		12156	41.6	2.44
	508.2	7100 TO BEOWAWE (WP Conn.)	P	12145	26.3	2.31
	520.3	BARTH (WP Conn.)	P	12137	14.2	2.18
S 12.52 AM	534.5	Yd. Lmts. TO-R CARLIN (WP Conn.)	BKYPQ	12129	0.0	2.00 AM
Arrive Daily		(288.3)				Leave Daily
6						5

EAST-WARD Mile Post Location	STATIONS SIDING CAPACITIES AND FACILITIES	Station Number	WEST-WARD Distance
358.7	Yd. Lmts. TO-R WENDEL	08398	22.3
349.8	8.9 HERLONG	08510	13.4
336.4	ABS 13.4 FLANIGAN IP	08540	0.0

Oregon Division stations Herlong and Wendel shown for information only.

Mina Branch			
288.1	Yd. Lmts. HAZEN	14160	128.9
307.0	3070 18.9 APPIAN	14320	110.0
328.0	4025 21.0 WABUSKA	14341	89.0
354.2	3130 26.2 SCHURZ	14367	62.8
384.4	2200 30.2 THORNE	14370	32.6
408.2	23.8 LUNING	14380	8.8
417.0	Yd. Lmts. TO-R MINA	14395	0.0

Fallon Branch			
288.1	R Yd. Lmts. HAZEN	14160	15.8
303.9	15.8 FALLON	14210	0.0

ADDITIONAL STATIONS			
Capacity and Direction of entry into Spurs	Mile Post	NAME	Station Number
1715W P	260.2	Wunotoo . (Spur)	16038
4210 ..	348.7	Kodak	14077
2550E } P	350.1	Colado . . (Spur)	14075
980W		" "	
1325W		" "	
1640E ..	434.0	Golconda . (Spur)	12189
245E ..	461.3	Valmy . . (Spur)	12175
3185E ..	487.7	Argenta . (Spur)	12159
245E ..	517.0	Harney . . (Spur)	12141
2790E P	525.7	Palisade . (Spur)	12134
Mina Branch			
615 ..	313.8	Weeks	14327
2630 ..	330.8	Fort Churchill .	14343
.. ..	331.9	Lux	14345
.. ..	347.7	Reservation . . .	14361

Time shown for eastward first class trains at Weso and Carlin for information only. See Western Pacific Railroad timetable for eastward train movements between Weso and Carlin.

SACRAMENTO DIVISION TIMETABLE No. 8, OCTOBER 30, 1977

4

ROSEVILLE SUBDIVISION

EASTWARD				No. 2 Track				WESTWARD							
FIRST CLASS	Mile Post Location	Station Number	Distance from Sacramento	STATIONS				STATIONS							
6				SIDING CAPACITIES AND FACILITIES				SIDING CAPACITIES AND FACILITIES							
Passenger															
Leave Daily															
PM 3.50	89.0	23050	0.0	Double Track TO-R SACRAMENTO BKIYPQ 1.1 P SACRAMENTO (15th St.) 1.8 IYPQ ELVAS 3.1 P BENALI 7.9 BKIPQ ANTELOPE 3.8 BKIYPQ TO-R ROSEVILLE 4.0 P ROCKLIN Yd. Lmts. 9.6 P NEWCASTLE 4.0 P AUBURN, NEVADA ST. E-4200 4.9 P BOWMAN E-6400 Yd. Lmts. 12.6 BKYPQ TO COLFAX 4.4 P CAPE HORN E-6400 6.2 P GOLD RUN 8.5 P MIDAS 4.8 P BLUE CANON M-5400 Yd. Lmts. 4.8 IYPQ EMIGRANT GAP 7.6 IP SHED 10 1.3 P CISCO 5.2 P TROY E-6336 6.5 BKIYPQ TO NORDEN 5.3 IP SHED 47 E-4850 Yd. Lmts. 9.3 BKIYPQ TO TRUCKEE 14.4 P FLORISTON 9.4 P VERDI 11.1 P RENO Yd. Lmts. 3.3 BKYPQ TO-R SPARKS (154.9)											
	88.9	23040	1.1												
	90.0	23037	2.9												
	91.8	23021	6.0												
	94.9	23008	13.9												
4.08	102.8	23000	17.7												
4.15	106.6	16480	21.7												
	110.6	16450	31.3												
4.31	120.2	16440	35.3												
4.36	124.2	16425	40.2												
4.42	129.1	16300	52.8												
s 5.00	141.7	16270	57.2												
	146.1	16259	63.4												
5.09	146.0	16242	71.9												
5.21	152.2	16234	76.7												
5.38	160.7	16229	81.5												
	165.5	16220	89.1												
5.48	166.6	16217	90.4												
	166.6	16211	95.6												
6.39	192.0	16190	102.1												
	197.3	16175	107.4												
	198.7	16160	116.7												
s 7.14	208.0	16148	131.1												
	222.4	16133	140.5												
7.35	231.8	16110	140.5												
	231.8	16110	151.6												
s 8.05	242.9	16105	154.9												
	242.9	16105	154.9												
s 8.14 PM	246.2	16105	154.9												
Arrive Daily															
6															

ADDITIONAL STATIONS				
Capacity and Direction of entry into Spurs	Mile Post	NAME	Station Number	
Roseville-Sparks No. 2 Track				
540 W	126.5	Foothill..... (Spur)	16430	
..	148.5	Magra.....	16265	
..	156.8	Towle.....	16247	
..	177.9	Crystal Lake.....	16221	
..	197.7	Eder.....	16176	
..	200.9	Andover.....	16172	
..	216.3	Boea.....	16154	
..	238.0	Lawton.....	16125	
..	241.0	West Reno.....	16122	

ADDITIONAL STATIONS				
Capacity and Direction of entry into Spurs	Mile Post	NAME	Station Number	
Sparks-Roseville No. 1 Track				
490E	241.0	West Reno..... (Spur)	16122	
1125E	238.0	Lawton..... (Spur)	16125	
835W	216.2	Boea..... (Spur)	16154	
..	200.9	Andover.....	16172	
..	197.7	Eder.....	16176	
880E	193.4	Summit..... (Spur)	16181	
..	177.9	Crystal Lake.....	16221	
880E	157.2	Towle..... (Spur)	16247	
..	148.9	Magra.....	16265	

RULE 5: Time applies at station signs between Sparks and Sacramento.

ROSEVILLE SUBDIVISION

EAST-WARD	Mile Post Location	STATIONS SIDING CAPACITIES AND FACILITIES	Station Number	WEST-WARD	Distance
		Walnut Grove Branch			
89.0	88.7	Yd. Lmts. BKIYPQ TO-R SACRAMENTO	23050		16.8
	97.5	8.8 FREEPORT	23214		8.0
	104.6	8.0 HOOD JCT.	23226		0.0
(33.2)					

ADDITIONAL STATIONS

Capacity and Direction of entry into spurs	Mile Post	NAME	Station Number
.. ..	91.8	Walnut Grove Branch Baths.....	23204
.. ..	94.2	Del Rio.....	23208

STOCKTON SUBDIVISION

EAST-WARD	Mile Post Location	STATIONS SIDING CAPACITIES AND FACILITIES	Station Number	WEST-WARD	Distance
		Placerville Branch			
94.7		Yd. Lmts. BRIGHTON IP	23110		55.0
96.4		1.7 PERKINS	23117		53.3
98.9		2.5 MAYHEW	23122		50.8
101.6		2.7 MILLS	23127		48.1
104.4		Yd. Lmts. 2.8 CITRUS	23131		45.3
110.1		5.7 NATOMA	23141		39.6
111.1		Yd. Lmts. 1.0 FOLSOM JCT. Y	23143		38.6
118.0		6.9 WHITE ROCK	23158		31.7
142.7		24.7 EL DORADO	23184		7.0
145.0		2.3 DIAMOND SPRINGS	23186		4.7
149.7		Yd. Lmts. 4.7 PLACERVILLE	23190		0.0
(55.0)					

STOCKTON SUBDIVISION

EAST-WARD	Mile Post Location	West Side Line	Station Number	WEST-WARD	Distance from Fresno Yard
STATIONS SIDING CAPACITIES AND FACILITIES					
71.5	82.9	TO-R TRACY BKIYPQ	25300		126.4
	84.9	2.0 LYOTH IP	25310		124.4
	100.4	5040 Yd. Lmts. 15.5 WESTLEY P	25343		108.9
	107.4	2540 Yd. Lmts. 7.0 PATTERSON P	25352		101.9
	119.5	2690 Yd. Lmts. 12.1 TO NEWMAN PQ	25368		89.8
	123.5	2450 Yd. Lmts. 4.0 GUSTINE P	25373		85.8
	140.4	4500 Yd. Lmts. 16.9 LOS BANOS P	25395		68.9
	153.0	2100 Yd. Lmts. 12.6 DOS PALOS P	25410		56.3
	166.2	Yd. Lmts. 5040 13.2 FIREBAUGH P	25426		43.1
	174.5	4360 8.3 TO MENDOTA YPQ	25440		34.8
	181.9	1910 Yd. Lmts. 7.4 R INGLE P	27100		27.4
	193.0	5390 Yd. Lmts. 11.1 KERNAN P	27220		16.3
	202.5	Yd. Lmts. 9.5 PRATTON P	27236		6.8
209.3	201.8	6.8 TO-R FRESNO YARD BKYPQ JD	27325		0.0
(126.4)					

Biola Branch

208.6	Yd. Lmts. R	BIOLA JCT. P	27300	0.0
200.5		BIOLA	27315	8.1

(8.1)

Riverdale Branch

181.9	Yd. Lmts. R	1910 INGLE P	27100	32.7
199.0		2730 HELM	27122	15.6
214.6		730 15.6 RIVERDALE	27145	0.0

(32.7)

ADDITIONAL STATIONS

Capacity and Direction of entry into Spurs	Mile Post	NAME	Station Number
450E ..	92.6	Vernalis.....	25336
490E P	94.9	Solyo.....	25338
2450 Yd. Lmts. P	113.2	Crows Landing.....	25359
980 P	129.3	Ingomar.....	25379
490E Yd. Lmts. ..	135.6	Volta.....	25387
290E P	159.8	Oxalis.....	25419
390W P	169.0	Benito.....	25431
1960 Yd. Lmts. P	170.8	Cromir.....	25435
830 P	205.3	Crayold.....	27240
Biola Branch			
190E ..	208.2	Rayland..... (Spur)	27306
190W ..	202.5	Raco..... (Spur)	27312
Riverdale Branch			
580 ..	187.2	Tranquility.....	27107
1560 ..	191.7	San Joaquin.....	27114
.. ..	206.2	Burrell.....	27131
Placerville Branch			
1520W ..	97.5	Manlove..... (Spur)	23119
635W ..	107.4	Nimbus..... (Spur)	23138
245 ..	131.4	Dugan.....	23175
735 ..	131.7	Bullard.....	23177
245W ..	147.7	Apex..... (Spur)	23189

SACRAMENTO DIVISION TIMETABLE No. 8, OCTOBER 30, 1977

6

STOCKTON SUBDIVISION

WEST- WARD	East Side Line	Station Number	EAST- WARD
Mile Post Location	STATIONS SIDING CAPACITIES AND FACILITIES		Distance
136.2	W-4350 ELVAS IYPQ	23037	64.7
133.2	7400 BRIGHTON IP	23110	61.7
132.0	1.2 POLK IP	23113	60.5
129.0	3.0 FLORIN P	26014	57.5
122.9	8350 6.1 ELK GROVE P	26022	51.4
115.5	8350 7.4 NEED P	26032	44.0
111.7	R 3.8 GALT P	26038	40.2
106.2	8350 5.5 ACAMPO P	26211	34.7
103.3	6070 2.9 LODI BKYPQ	26220	31.8
93.9	9.4 AKERS P	26415	22.4
92.7		1.2 EL FINAL P	26417
90.9	Yd. Lmts. 1.8 STOCKTON BKIYPQ	26420	19.4
81.5	W-3870 9.4 LATHROP YP	26620	10.0
(64.7)			
EAST- WARD		WEST- WARD	
71.5	Yd. Lmts. TO-R TRACY BKIYPQ	25300	0.0
81.5	W-3870 10.0 LATHROP YP	26620	0.0
81.5	LATHROP YP	26620	108.9
92.9	8350 6.5 CALLA YP	26723	102.4
99.4	8350 8.6 COVELL P	26739	93.8
108.0	5.1 MODESTO BKYPQ	26750	88.7
113.1	8350 4.3 CERES P	26775	84.4
117.4	8.8 TURLOCK PQ	26790	75.6
126.2	8350 3.4 ALCANT P	26805	72.2
129.6	8350 10.2 ARENA P	26822	62.0
139.8	8350 7.6 FERGUS P	26834	54.4
147.4	3.1 MERCED BPQ	26840	51.3
150.5	8350 6.1 LINGARD P	26867	45.2
156.6	8300 11.6 CHOWCHILLA P	27005	33.6
168.2	8410 11.0 NOTARB P	27019	22.6
179.2	4.7 MADERA PQ	27025	17.9
183.9	8350 6.3 IRRIGOSA P	27033	11.6
190.2	R 10090 9.0 BIOLA JCT. P	27300	2.6
199.2	Yd. Lmts. TO-R FRESNO YARD BKYPQ	27325	0.0
201.8			
(108.9)			

EAST- WARD	STATIONS	Station Number	WEST- WARD
Mile Post Location	SIDING CAPACITIES AND FACILITIES		Distance from End
Oakdale Branch			
90.9	Yd. Lmts. R STOCKTON BKIYPQ	26420	35.4
122.4	2450 31.5 OAKDALE P	26550	3.9
126.3	3.9 CLARIBEL	26580	0.0
(35.4)			
Kentucky House Branch			
103.5	Yd. Lmts. R LODI BKYPQ	26220	39.1
107.1	R 3.6 VICTOR	26309	35.5
142.6	35.5 KENTUCKY HOUSE	26355	0.0
(39.1)			
Woodbridge Branch			
103.4	Yd. Lmts. R LODI BKYPQ	26220	2.4
105.8	Yd. Lmts. R 2.4 WOODBRIDGE	26230	0.0
(2.4)			
Ione Branch			
111.7	R 1370 GALT P	26038	27.1
138.8	27.1 IONE	26140	0.0
(27.1)			

ADDITIONAL STATIONS			
Capacity and Direction of entry into Spurs	Mile Post	NAME	Station Number
1510E	P	Urgon..... (Spur)	26213
290E	P	Tomsbur..... (Spur)	26408
980W	..	Castle..... (Spur)	26411
1710	P	French Camp.....	26610
8250	P	Manteca.....	26720
3250	P	Ripon.....	26729
..	..	Salida.....	26734
..	..	West Modesto.....	26745
12100	P	Keyes..... (Spur)	26779
290W	..	Delhi..... (Spur)	26810
980W	..	Livingston..... (Spur)	26815
5800E	P	Atwater.....	26829
8800	P	Creegan.....	26861
..	P	Athlone.....	26872
..	P	Berenda.....	27015
2450	P	Borden..... (Spur)	27039
1220W	P		
Oakdale Branch			
..	..	Walshall.....	26513
..	..	Peters.....	26521
880W	..	Adela..... (Spur)	26542
Kentucky House Branch			
..	..	Brandywine.....	26305
880	..	Lockeford.....	26314
..	..	Clements.....	26321
340	..	Valley Spring.....	26339
530	..	Toyon.....	26345
Ione Branch			
930	..	Clay.....	26112
4800E	..	Rancho Seco.. (Spur)	26114
1860	..	Carbondale.....	26124
1070	..	Indian Hill.....	26127
1370W	..	Edwin..... (Spur)	26129
680W	..	Dagon..... (Spur)	26137

EAST VALLEY SUBDIVISION

EAST-WARD	East Valley Line	Station Number	WEST-WARD
Mile Post Location	STATIONS SIDING CAPACITIES AND FACILITIES		Distance
106.6	TO-R ROSEVILLE BKYPQ	23000	105.1
112.8	8370 SUNSET-6.2 P WHITNEY RANCH	22579	98.9
117.0	4.2 P LINCOLN	22574	94.7
122.1	8260 5.1 P BROCK	22567	89.6
134.2	8350 12.1 P OSTROM	22547	77.5
139.8	5.6 P DANTONI JCT.	22531	71.9
140.8	1.0 BKYPQ R MARYSVILLE	22500	70.9
141.8	1.0 IYP BINNEY JCT.	22404	69.9
144.7	8450 2.9 P BERG	22249	67.0
155.9	8420 11.2 P FAGAN	22235	55.8
158.0	2.1 P GRIDLEY	22232	53.7
167.4	8185 9.4 P RICHVALE	22220	44.3
178.1	10.7 P DURHAM	22207	33.6
184.2	8540 6.1 KYPQ CHICO	22030	27.5
193.6	8378 9.4 P ANITA	22019	18.1
203.0	8200 9.4 P VINA	22011	8.7
211.7	8.7 YP TEHAMA	20195	0.0
	(105.1)		

Automatic Block Signal System

Centralized Traffic Control

EAST-WARD	STATIONS SIDING CAPACITIES AND FACILITIES	Station Number	WEST-WARD
Mile Post Location			Distance
Stirling City Branch			
184.2	Yd. Lmts. CHICO BKYPQ	22030	31.2
215.4	31.2 Y STIRLING CITY	22140	0.0
(31.2)			
Yuba City Branch			
144.7	8450 P	22249	3.84
144.4	BERG		
147.6	3.2 YUBA CITY	22304	0.64
148.24	0.64 END OF BRANCH		0.0
(3.84)			
Oroville Branch			
Via WPRR See WP Timetable Special Instructions and Rules for movement between Binney Jct. and Oroville.			
122.7	IP BINNEY JCT.	22404	25.2
147.9	25.2 (Via WPRR) OROVILLE	22430	0.0
(25.2)			

ADDITIONAL STATIONS			
Capacity and Direction of entry into Spurs	Mile Post	NAME	Station Number
1420E ..	188.3	Stirling City Branch	22105
930 ..	198.2	Butte Creek..... (Spur)	22116
		Paradise.....	

ADDITIONAL STATIONS			
Capacity & Direction of entry into spurs	Mile Post	NAME	Station Number
East Valley Line			
2450	P 118.4	Clayton	22572
2745	.. 121.0	Ewing	22569
..	P 131.2	Erle	22551
..	.. 138.9	Rupert	22541
685E	.. 149.8	Sunset	22242
..	.. 151.5	Live Oak	22239
2400	P 161.4	Biggs	22228
295E	.. 164.1	Riceton	22224
..	P 191.3	Nord	22023
1370	P 209.7	Los Molinos	22003

SACRAMENTO DIVISION TIMETABLE No. 8, OCTOBER 30, 1977

8

WEST VALLEY SUBDIVISION

EAST- WARD FIRST CLASS	Mile Post Location	West Valley Line		Station Number	Distance from Dunsmuir	WEST- WARD FIRST CLASS	11 Passenger	Arrive Daily	EAST- WARD	Mile Post Location	Colusa Branch		Station Number	WEST- WARD Distance
		STATIONS SIDING CAPACITIES AND FACILITIES									STATIONS SIDING CAPACITIES AND FACILITIES			
14 Passenger Leave Daily														
PM 10.36	75.6	N-3351 Yd. Lmts. TO-R	DAVIS	23323	214.0						5360 R	HARRINGTON	21305	25.2
10.42	80.7	4985	MERRITT	21510	208.9			AM 5.57			Yd. Lmts. 12.5	GRIMES	21171	12.7
10.47	84.9	Yd. Lmts. 4.2 TO-R	WOODLAND	21340	204.7			5.45			12.2	COLUSA	21156	0.5
	89.9	1910	YOLO	21330	199.7			5.41			0.5	END OF BRANCH		0.0
10.57	95.8	5235	ZAMORA	21320	193.8						(25.2)			
11.09	108.3	5360 R	HARRINGTON	21305	181.3			5.30			Hamilton Branch			
11.23	124.2		WILLIAMS	21255	165.6			5.18			1535 Yd. Lmts. R	WYO	21030	18.7
11.27	129.1	5065	CORTENA	21248	160.7			5.04			2855 Yd. Lmts. P	HAMILTON	21113	8.3
11.34	138.3	5015	DELAVAN	21237	151.5			4.59			8.3	END OF BRANCH		0.0
PM 11.46	149.9	5495 Yd. Lmts. TO-R	WILLOWS	21222	139.9			4.50			(30.0)			
AM 12.04	165.4	Yd. Lmts. 15.5 TO-R	ORLAND	21204	124.4			4.38			Knights Landing Branch			
12.06	167.0	1535 R	WYO	21030	122.8			4.21			4895 Yd. Lmts. TO-R	WOODLAND	21340	3.3
12.17	178.5	2015	CORNING	21025	111.3			4.16			2.8	SUGARFIELD	21404	2.2
12.24	186.3		TEHAMA	20195	103.5			4.04			0.5	END OF BRANCH		0.0
	211.7		GERBER	20190	101.4			3.57			(3.3)			
	213.8		RAWSON	20178	96.3						Matheson Branch			
	218.9	TO-R	RED BLUFF	20173	91.8						Yd. Lmts. R	REDDING	20110	10.7
	223.4	8345	BLUNT	20165	86.3						2.8	MIDDLE CREEK	20120	7.9
	228.9	8200	DRAPER	20160	78.7						2.2	KETT	20125	5.7
	236.5	8445	CULP	20152	71.0						5.7	MATHESON	20130	0.0
	244.2	9245	GIRVAN	20140	61.7						(10.7)			
s 1.17	258.2	10820 TO-R	REDDING	20110	57.0			3.07						
	263.0	5290	SILVERTHORN	20067	52.2									
	266.3	5095	CENTRAL VALLEY	20063	48.9									
	270.4	9350	GRAY ROCKS	20058	44.8									
	277.6	6120	OBRIEN	20055	37.6									
	281.2	5095	MEAD	20051	34.0									
	285.7	8300	LAKEHEAD	20045	29.5									
	289.8	5255	DELTA	20033	25.4									
	296.7	5570	LAMOINE	20029	21.9									
	300.2	4970	GIBSON	20025	18.1									
	304.0	8300	SIMS	20019	12.7									
	309.4	5385	CONANT	20014	9.0									
	313.1	5805	CASTLE CRAG	20005	3.8									
	318.3		DUNSMUIR YARD	07255	0.9									
s 3.09 AM	322.1	TO	DUNSMUIR	07250	0.0			1.19 AM						
Arrive Daily			(214.0)					Leave Daily						
14								11						

ADDITIONAL STATIONS			
Capacity and Direction of entry into Spurs	Mile Post	NAME	Station Number
West Valley Line			
1175W ..	92.1	Dufour..... (Spur)	21325
835W P	103.2	Dunnigan..... (Spur)	21312
1125E ..	106.4	Hershey..... (Spur)	21308
1470E ..	113.5	Arbuckle..... (Spur)	21266
1470E ..	117.6	Genevra..... (Spur)	21261
..	126.8	Delphos.....	21251
1370E ..	133.0	Maxwell..... (Spur)	21243
3235E ..	156.8	Artois..... (Spur)	21214
..	162.0	Greenwood.....	21208
390E ..	181.6	Richfield..... (Spur)	21020
..	215.8	Proberta.....	20182
..	224.5	Glade.....	20170
1960 ..	240.4	Cottonwood.....	20157
2645 ..	247.1	Anderson.....	20148
Colusa Branch			
930E ..	162.1	Ordbend..... (Spur)	21123
1960 ..	178.6	Cory.....	21103

RULE 5. Davis: Time applies at station sign except time applies for No. 14 at east switch north siding.
Tehama: Time applies at junction switch.

DEFINITIONS

Holidays:

New Year's Day, January 1,
 Washington's Birthday, third Monday in February,
 Decoration Day, last Monday in May,
 Independence Day, July 4,
 Labor Day, first Monday in September,
 Veteran's Day, November 11,
 Thanksgiving Day, fourth Thursday in November,
 Christmas Day, December 25.

Speeds: Restricted Speed is revised to read:

A speed that will permit stopping within one-half the range of vision short of train, engine, car, stop signal, derail or switch not properly lined and looking out for broken rail, but not exceeding 20 MPH.

Note. ADD:

Flammable Compressed Gas (FCG): also applies to Flammable Gas (FG).

RULE A. Current Rules and Regulations of the Transportation Department were effective October 31, 1976.

RULE C. First paragraph will not become effective until further notice.

RULE 1. Employee charged with the duty of maintaining standard clock with correct time may obtain standard time by telephone from San Francisco extension 22462.

RULE 3. Conductors, engineers, train order and/or interlocking operators who go on duty at locations where there is no standard clock may obtain standard time by telephone from San Francisco extension 22462.

RULE 17-D. First paragraph is revised to read:

Oscillating white light on engines, when leading end is so equipped, must be operated both day and night when moving, except it may be extinguished when meeting trains, passing trains, or during switching operations provided movement does not involve crossing at grade. The same requirements apply when leading end of engine or top of lead unit is equipped with an amber or white light which flashes or rotates.

RULE 21. Trains handling loads of excess dimensions covered by train order must be identified within CTC, Interlocking limits and on double track.

RULE S-72. Westward trains are superior to trains of the same class in the opposite direction.

RULE 81-A. Item (f) is revised to read:

(f) View of track for entire length of block to be occupied and to end of adjoining block in both directions.

RULE 81-A. Where electric or mechanical switch locks are installed, be governed by instructions posted in telephone booths, on doors or on housings of electric or mechanical switch lock.

RULE 93. Is revised to read:

Within yard limits, ENGINES, after complying with provision of Rules 81 or 81-A, may use main track without train-order authority, clearing the time approaching first-class trains are due to leave the last preceding station where time is shown. Flag protection against trains and engines is not required.

All trains and engines must move at RESTRICTED SPEED on main track within yard limits, except where movements are governed by block signal indication.

RULE 98. At interlocked railroad crossings at grade, cars or engines must not be cut off nor left within interlocking limits in such a way as to foul any part of the crossing frogs.

RULE 99. FLAG PROTECTION OUTSIDE OF BLOCK SYSTEM LIMITS: Is revised to read:

When a train is moving on main track at less than half the maximum authorized timetable speed for any train at that location, flagman must drop single lighted fuses at intervals that do not exceed the burning time of the fusee, and continue observation from rear of train. If train is seen approaching, stop signals must be promptly displayed. If necessary, and speed of train and conditions will safely permit, flagman must detrain immediately placing torpedoes and proceed toward approaching train displaying stop signals.

When a train is moving on main track at or more than half the maximum authorized timetable speed for any train at that location, under circumstances in which it may be overtaken, flagman must consider grade, track curvature, weather conditions, sight distance, and speed of the train relative to following trains, when deciding if lighted fuses should be dropped.

When a train stops on main track under circumstances in which it may be overtaken by another train, the engineer will orally or by whistle signal promptly instruct the flagman to protect the rear. Unless recalled, flagman must go back immediately to insure full protection against a train moving at MAXIMUM AUTHORIZED SPEED, for any trains at that location, placing torpedoes on rail one mile behind train. He must then continue to a point two miles behind train where he will place additional torpedoes on rail and place a lighted fusee.

Flagman will then return toward rear of his train, remaining a sufficient distance but not less than one mile from rear, to enable him to stop a following train.

When providing the prescribed protection, if a flagman reaches a point within yard limits, he will place torpedoes on rail at yard limit board and it will not be necessary to go any additional distance. Until such time as flagman is recalled, he will remain at that point or at a point not less than one mile from rear of train, whichever is applicable.

When train is ready to proceed, engineer will recall the flagman orally or by whistle signal. When recalled and SAFETY OF TRAIN WILL PERMIT, he must place torpedoes on rail if none have previously been placed. He must leave a lighted fusee and thereafter return to his train, leaving additional lighted fusees at intervals that do not exceed the burning time of the fusee. Torpedoes which have been placed will be left on rail when flagman is recalled. When flagman arrives at rear of train and train commences moving, he must leave a lighted fusee, and drop single lighted fusees at intervals that do not exceed the burning time of the fusee until train attains a speed not less than half the maximum authorized timetable speed for any train at that location.

If a train is seen or heard approaching AT ANY TIME while train is standing, flagman must immediately place torpedoes on rail if they have not been previously placed. He must then proceed toward approaching train displaying stop signals. When safety of train will permit, flagman may return to his train.

The front of the train must be protected in the same manner when necessary by the brakeman or by another crew member if brakeman not available, except flagman must not return toward his train under any circumstances until recalled.

The train must be protected in the same manner before fouling main track when protection by flagman is required as prescribed by Rule 81, except within yard limits protection will be provided in direction(s) necessary a sufficient distance beyond switch where movement is to enter main track, to be able to stop any train or engine which may approach. When recalled, and if conditions warrant, flagman will leave a lighted fusee.

Before a train makes a reverse movement on main track, necessary additional protection must be provided.

Flag protection is not required when relieved from doing so by train order.

When rear of train is standing within interlocking, A-PB or yard limits, flag protection to the rear is not required.

During stops on main track where flag protection is not required, member of crew of train carrying passengers must take a position on ground at rear vestibule of rear car.

SPECIAL INSTRUCTIONS—ALL SUBDIVISIONS

Note: SUFFICIENT DISTANCE. A distance from train where a flagman will place or give signals to engineer of an approaching train to permit engineer to take immediate action consistent with good train handling techniques, without emergency brake application, where he can stop his train short of train, equipment, or obstruction being protected. In making decision as to distance required, flagman is expected to exercise good judgment, taking into consideration the following:

- (a) Maximum authorized speed in territory.
- (b) Grade conditions.
- (c) Weather conditions.
- (d) Visibility.
- (e) Curvature of track.

RULE 102. Should a passenger train break in two or an emergency application of brakes occur while in motion on grade, head brakeman will immediately go toward rear, close angle cock at opening if train has parted, apply hand brakes, and turn up retaining valves on detached portion. After train is coupled air must be applied from engine before hand brakes and retaining valves are released.

If necessary to leave detached portion on main track, rear truck of detached portion on ascending grade or lead truck of detached portion on descending grade must be blocked or chained in such manner as to derail car should there be an uncontrolled movement.

RULE 103. Except as otherwise provided in this rule or by other Special Instructions or timetable bulletins, a public grade crossing which is blocked by a stopped train, other than a passenger train, must be opened within ten minutes, unless no vehicle or pedestrian is waiting at the crossing. Such a cleared crossing must be left open until it is known that train is ready to depart. When recoupling at public crossings trains shall be moved promptly consistent with safety.

Switching movements over public grade crossings should be avoided whenever reasonably possible. If not reasonably possible, such crossings must be cleared frequently to allow a vehicle or pedestrian to pass and must not be occupied continuously for longer than ten minutes unless no vehicle or pedestrian is waiting at the crossing.

In the event of any uncontrolled blockage involving more than one grade crossing and a peace officer is on the scene, primary consideration shall be given to the clearing of that crossing which, in the peace officer's judgment, will result in minimum delay to vehicular traffic.

Train or yard crew member of a train blocking a public crossing shall immediately take all reasonable steps, consistent with the safe operation of such train, to clear the crossing upon receiving information from a peace officer, member of any fire department, or operator of an emergency vehicle, that emergency circumstances require the clearing of the crossing.

In the event of any uncontrolled blocking not otherwise provided for in this rule, crossing shall be cleared with reasonable dispatch.

RULE 104-D. Running switches will be made only when in the judgment of the conductor it is necessary and with his personal supervision.

RULES 201 and 221-A. Train orders will be issued by authority and over initials of Chief Train Dispatcher C. L. Kennedy and OK'd clearances must bear initials of Chief Train Dispatcher C. L. Kennedy.

RULE S-244. At locations where movement of extra trains or engines are authorized by use of train register, all lines of each page of the train register must be used and filled in before turning and starting a new page.

AUTOMATIC BLOCK SIGNAL SYSTEM

RULE 505. Where signal protection is provided for movements from an adjacent track to main track, push buttons and lights are installed in box near each of the two signals, with time-release feature, to clear signals on one track when the control circuit on the other track is occupied.

Train on main track to let train on siding pass may clear signal on siding by pressing button bearing number of signal on siding. Train on siding to let train on main track pass should not pass APPROACH CIRCUIT sign, but when necessary to do so, may clear signal on main track by pressing button bearing number of signal on main track.

Further instructions posted inside push-button box.

RULE 508. Is revised to read:

Except as provided in Rules 509, 663 or 744, when an automatic block signal governing movement ON SINGLE TRACK WITHIN YARD LIMITS displays stop indication, train or engine, after stopping, may proceed at RESTRICTED SPEED under one of the following conditions:

- (a) When a preceding train is seen in the block and intervening track is seen to be clear.
- (b) When view of track is clear to end of second block.
- (c) When no movement is seen or heard approaching, train or engine must be moved forward until leading wheels are past insulated joints at the signal and wait five minutes at that point.

RESTRICTED SPEED must not be exceeded until rear of train or engine has passed out of block.

LETTER-TYPE INDICATORS

RULE 705. For information concerning letter-type indicators in connection with Hot Box Detectors and their appurtenances refer to Rule 827, All Subdivisions.

GENERAL REGULATIONS

RULE 812. Section entitled "Safety Rules," pages II-1 through II-12, and portion of section entitled "Emergency Procedures" on pages III-4 through III-6, contained in Amtrak's Manual of Instructions for Conductors and Trainmen in Amtrak Service, do not apply to employees of Southern Pacific Transportation Company.

RULE 822. Second paragraph is revised to read:

If uncoupling lever on one side fails to work, lever on other side must be used. When necessary to raise lock pins or change alignment of couplers on cars or engines, THEY MUST BE SEPARATED NOT LESS THAN 50 FEET AND STOPPED. Under no circumstances may feet be used to make adjustments.

RULE 825. At terminals where instructions require application of hand brakes on freight trains, outgoing crews must not release hand brakes until road engine is coupled, air test completed and blue sign removed.

Many new cars are equipped with truck-mounted brakes. The hand brake is effective on these cars on "B" end only. It will be necessary to check "B" end of these cars to determine if hand brake has been released.

Rail skids are hung on posts at locations listed under subdivisions. When using rail skid it must be placed on rail and leading wheel of first car in descending direction run onto rail skid and hand brakes applied, if brakes are operative, before engine is detached. Train crews picking up cars from these locations must remove rail skid, return to proper location and lock in place where lock is provided.

RULE 827. Engines running light on descending grade without dynamic brake in operation must stop a sufficient length of time to permit wheel heat radiation if there is INDICATION OF OVERHEATING.

When trains are stopped by hot box detectors, dragging and/or derailed equipment detectors at locations where bridges, trestles, etc. are not provided with walkways train may be moved slowly ahead a sufficient distance to permit inspection.

DRAGGING AND/OR DERAILED EQUIPMENT DETECTORS

Where dragging and/or derailed equipment detectors are installed as listed under subdivisions, revolving red beacon will be mounted on hot box detector house, on post or relay case adjacent to detector and will be normally dark. When dragging and/or derailed equipment detector is activated, the revolving red light will be displayed.

Unless otherwise provided revolving red beacon will apply to trains in both directions, and when activated enginemen or trainmen must stop train promptly in accordance with Air Brake Rule 5. Sec. D. and make inspection of train and track, advising train dispatcher of conditions found.

LOOSE WHEEL DETECTORS

If indication is for loose wheel, all wheels and journals must be inspected on car indicated as well as on the car ahead and the car behind.

ROLLER BEARINGS LOOSE OR MISSING CAP SCREWS

During inspection by trainmen, if any roller bearing is found with one cap screw loose or missing and hot box detector has not been activated and check with tempilstick reveals no overheated condition, train may proceed to the next terminal where car must be set out.

Under the same circumstances, when two or more roller bearing cap screws are found loose or missing, train may proceed with caution to the first available track where car must be set out.

HOT BOX DETECTORS

Four basic types of Hot Box Detectors are utilized. Crew members are to be familiar with the types and locations of these detectors.

Hot box detector scanner sites have a white light continuously displayed on track side of instrument house, except when a hot bearing is detected, at which time light will start flashing. Crew members must be alert for the light and, when flashing, conductor and engineer must immediately orally compare observation when means of communication is available.

Absence of white light must be promptly reported to train dispatcher and does not require train inspection.

TYPE A. LETTER "H" INDICATOR (RULE 705.) WITH DIGITAL READ-OUT.

When letter "H" is illuminated or it is known hot bearing has been detected by crew member observing the flashing white light at scanner site, train must be brought to immediate stop and inspection made to determine that it is safe to proceed. Where possible, inspection must be made before passing over switches or structures. After inspection, train must not exceed 15 MPH from point of inspection until stop is made at location of readout locator and be governed by instructions posted inside case.

Member of crew must make a physical count of axles from rear of train to axle indicated by digital readout and when hot bearing is not located then all journals of car indicated by detector as well as five cars on either side of the car involved must be inspected.

Unless entire train has previously been inspected after stopping for detector, all journals of train must be inspected when "H" is illuminated provided any of the following conditions exist:

1. No count shown on readout locator.
2. Red light below readout mark "Locator Out of Service" is illuminated.
3. Digital readout locator displays erroneous indication such as a duplication of numbers.
4. Numbers displayed exceed the number of axles in train.

After inspection has been completed train dispatcher must be notified of condition found. When it is safe to proceed, member of crew must push button below indicator panel to cancel numbers on the indicator. Case door must be closed and secured with switch lock.

When letter "W" is displayed it is an indication that preceding train has stopped due to a hot bearing indication but has not cancelled out system. Following trains must stop and not proceed until light is extinguished or permission is obtained from train dispatcher. After stopping, speed of 10 MPH or more should be obtained if possible before passing over detector provided restrictions permit.

TYPE B. LIGHT INDICATOR ARRAY & WHEEL SPRAY.

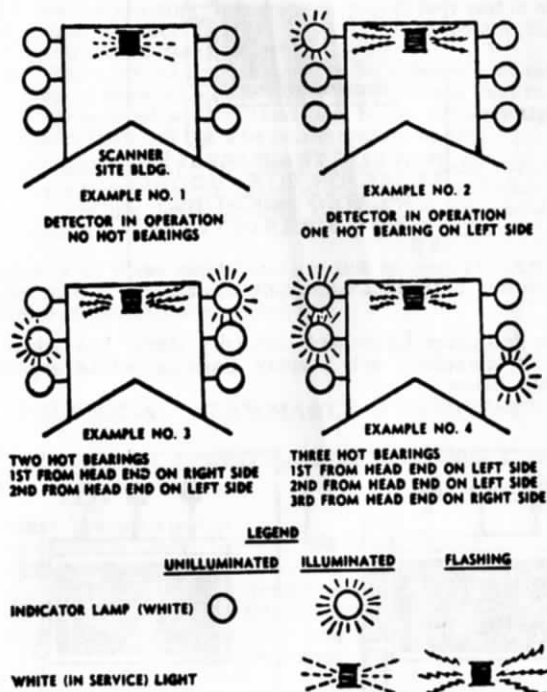

Detector instrument house is equipped with indicator array consisting of white lights as shown in diagram.

White light at top center of indicator array will be continuously displayed except when a hot bearing has been detected, at which time light will start flashing. Absence of white light must be promptly reported to train dispatcher.

Three vertical white lights are located on each side of indicator array. Lights on right side will be displayed for hot bearings on right side of train, and lights on left side will indicate hot bearings on left side of train, in direction of movement. Top light indicates first hot bearing, second light indicates second hot bearing, and third light indicates third hot bearing. Lights will indicate a maximum of three hot bearings on each train.

Truck of car with hot bearing will be sprayed with fluorescent dye marker for identification.

Crew members must be alert when passing these locations, and if hot bearing is detected, train must be stopped promptly, and inspection made to locate car with hot bearing.

All bearings on car marked, as well as car ahead, must be inspected.

When indicator array indicates hot bearings on train, and no dye marker is observed, all bearings of train must be inspected.

SPECIAL INSTRUCTIONS—ALL SUBDIVISIONS

TYPE C. MONITOR DISPLAY BOARD WITH INDICATOR LIGHTS.

A Monitor Display Board and hot box indicator lights, as shown in diagram, are mounted on a signal mast at side of track. The display board is illuminated as train passes and will display zeros in the absence of a hot bearing. Two seconds after the train passes the detector, the display board will display numerals indicating the accumulated axle count from the hot bearing to the rear of the train.

Absence of any numerical display after passage of a train must be promptly reported to train dispatcher.

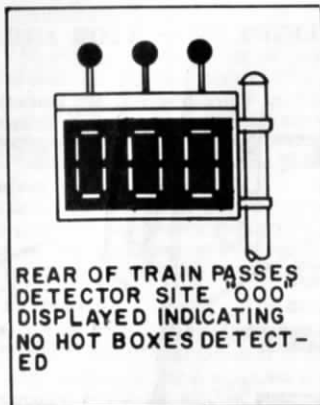

The indicator lights are normally dark, but when hot bearing is detected, will display flashing white aspect as illustrated below:

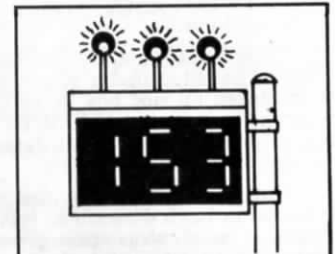
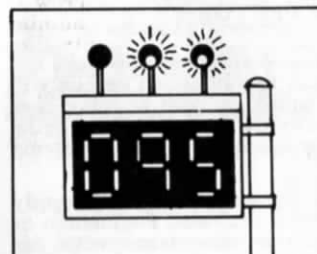
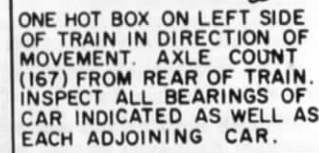
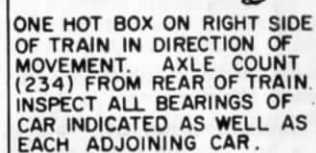
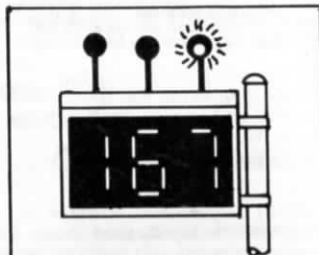
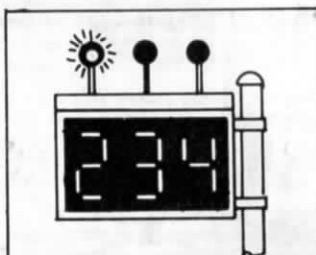

LEGEND

UNILLUMINATED

FLASHING

INDICATOR LAMP



As the train passes the detector, the right or left hot box indicator light on top of the board starts to flash immediately upon detection of a hot journal, indicating the side of the train having the overheated journal.

A flashing indicator light in the center indicates that another hot bearing (or bearings) was detected subsequent to the hot bearing which is numerically indicated on the display board.

When any indicator light displays flashing white aspect, train must be stopped promptly and inspection made to locate car with hot bearing.

Lights and illuminated numerals will automatically cancel out 90 seconds after entire train passes detector.

When hot bearing is not located then all journals of car indicated by detector as well as five cars on either side of the car involved must be inspected.

When it is known hot bearing has been detected by crew member observing the flashing white light displayed on track side of instrument house, and a numerical readout is not displayed on the display board, then train must be stopped promptly and all bearings of train must be inspected.

TYPE D. REMOTE READOUT BY RECORDER AT TERMINAL.

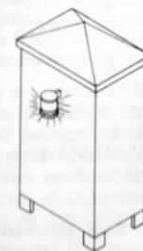

Instrument House

Readout is by recorder located at nearby terminal as shown under Rule 827 on each subdivision.

When white light is flashing on instrument house, train must be stopped promptly and when means of communication is available, crew member must contact personnel at location of recorder to determine location of hot bearing. If location of hot bearing cannot be determined by personnel at recorder, inspection must be made of all bearings.

Terminal personnel at recorder will advise train crew of location of overheated journal, location will be given as number of cars from caboose and location of journals from trailing end of car right or left: 1, 2, 3, 4 such as "R-3."

If lead truck of lead locomotive does not appear on tape, train crew is to be advised to carefully hand feel this truck.

If location of journal is furnished by personnel at recorder, but defect cannot be found, inspect all bearings of indicated car as well as all bearings of five cars on either side.

CHECKING FOR JOURNALS SUSPECTED OF OVERHEATING

Whenever an overheated journal is suspected due to hot box detector activation, rolling inspection or visual symptoms, a walking inspection must be made to find the exact car and journal and to observe for other physical defects on the train.

For roller bearing cars, special attention must be given to proper use of tempilstiks, loose or missing cap screws, temperature sensitive cap screws and loose or leaking seals.

For plain bearing cars, look for low oil; brass, pad or wedge defective or out of place, or water in journal box.

REPORTING OF HOT BOXES

When hot box detectors are actuated the following information is to be reported at next terminal in telegraph message form identified by symbol HB addressed jointly to Superintendent, Division Engineer, Signal Supervisor, and Chief Train Dispatcher, also General Manager—Amtrak, San Francisco when an Amtrak passenger train is involved.

1. Date and time stopped and M.P. location.
2. Train identification.
3. Car number and location in train (whether or not defect found).
4. Box location (1, 2, 3 or 4 from hand brake end of car, right or left side facing hand brake).
5. Disposition of car: If set out, state where. If inspection shows that it was not necessary to set out even though bearing was warm enough to activate the detector, advise what corrective action was taken to permit movement of car. If roller bearing equipped, so state.

NOTE: Report all cases where train passes over the detector without an indication having been displayed, but develops a hot bearing between detector and a point 20 miles beyond detector.

Whenever a roller bearing car experiences two successive hot box detector actuations and overheated journal or other cause of actuation cannot be found after required inspections were made and five cars checked either side, car may be continued in train with provision that conductor must report same at next terminal and inspection is made by qualified maintenance personnel.

Train dispatcher to notify terminal of mandatory inspection when brought to his attention.

If a roller bearing car experiences three successive hot box detector actuations, it must be set out.

Train dispatcher must:

1. Notify Car Department of cars set out.
2. Notify Car Department of cars which are known to have had two successive hot box detector actuations.
3. Submit CS-7159A "Preliminary Report of Overheated Journals" whenever hot box is experienced except if on actuation of type "D" yard approach hot box detector.

Connecting crews, if any, must be notified by incoming crew of failure to locate hot bearing if indication is received on any hot box detector system and car is not set out.

CONTINUOUS WELDED RAIL (CWR) TRAINS

Continuous welded rail trains consist of a tiedown car and a number of roller-rack cars and may contain other cars, such as threader cars and elevator cars to accompany movement. A steel-end box car, refrigerator car, or high-side gondola car must be positioned on each end of CWR train as a buffer car during all movements except preparatory to and during unloading.

In addition to other requirements of this rule, when a CWR train is stopped for any reason, inspection must immediately be made of as much of train as practicable and the following items checked if train is carrying a full or partial load:

- a. Check for undesired movement of rail. The tops of rails are painted adjacent to the tiedown rack on the tiedown car which is located near center of train. Paint marks on each tier of rail must be in line; otherwise, this is an indication of an undesired movement of rail.
- b. Check each rail end to make certain it overhangs the last supporting roller by at least 12 feet and is no closer than 12 feet from the next empty roller. Rails are marked 12 feet from each end.
- c. When a load contains continuous lengths of rail made up of more than one piece, check to see that rail joints are secured with at least four bolts, properly tightened, and that rail ends have not pulled apart.
- d. Check coupler operating levers to make certain they are in position to prevent uncoupling and that coupler operating lever locking devices are in position and locked.

When any of these conditions are not as required, train must not be moved until train dispatcher has been contacted and further instructions are received.

RULE 827-A. FLAMMABLE COMPRESSED GAS.

Following are shipping names of Flammable Compressed Gas:

Standard Transportation Classification Code	Shipping Name
4905705 . . .	Butadiene, inhibited (butadiene from alcohol)
4905704 . . .	Butadiene, inhibited (butadiene from petroleum)
4905703 . . .	Butadiene, inhibited (butadiene, impure, for further refining)
4905706 . . .	Butane
4905706 . . .	Liquefied petroleum gas (butane)
4905702 . . .	Butane (butane, impure, for further refining)
4905702 . . .	Liquefied petroleum gas (butane, impure, for further refining)
4905727 . . .	Compressed gases, n.o.s. (dispersant gases, nec. flammable)
4905748 . . .	Compressed gases, n.o.s. (iso-butene)
4905775 . . .	Compressed gases, n.o.s. (refrigerants, nec. liquid, flammable)
4905713 . . .	Cyclopropane
4905716 . . .	Difluoroethane
4905719 . . .	Difluoromonochloroethane
4905510 . . .	Dimethylamine, anhydrous
4905725 . . .	Dimethyl ether
4905734 . . .	Ethylene
4905749 . . .	Hydrocarbon gas, liquefied
4905749 . . .	Liquefied hydrocarbon gas
4905746 . . .	Hydrogen
4905745 . . .	Hydrogen, liquefied
4905410 . . .	Hydrogen sulfide
4905747 . . .	Isobutane
4905747 . . .	Liquefied petroleum gas (isobutane)
4905750 . . .	Isobutane (isobutane for further refinery processing)
4905750 . . .	Liquefied petroleum gas (isobutane for further refinery processing)
4905752 . . .	Liquefied petroleum gas
4905707 . . .	Liquefied petroleum gas (butene gas, liquefied)
4905711 . . .	Liquefied petroleum gas (butylene, impure for further refining)

SPECIAL INSTRUCTIONS—ALL SUBDIVISIONS

Standard Transportation Classification Code	Shipping Name
4905780	Liquefied petroleum gas (pintsch gas)
4905758	Methylacetylene—propadiene, stabilized
4905761	Methyl chloride
4905764	Methyl chloride—methylene chloride mixture
4905520	Methyl mercaptan
4905530	Monomethylamine, anhydrous
4905781	Propane
4905781	Liquefied petroleum gas (propane)
4905785	Trifluorochloroethylene
4905540	Trimethylamine, anhydrous
4905792	Vinyl chloride
4905795	Vinyl methyl ether, inhibited

When necessary to provide helper engine for trains handling tank cars containing Flammable Compressed Gas, helper engine must be placed in accordance with helper service instructions and there must be a proper separation of the helper engine from tank cars containing Flammable Compressed Gas.

Unless specifically authorized by Superintendent, trains or cuts of cars containing Flammable Compressed Gas must not exceed 8,000 feet.

RULE 829. In addition to other train inspection requirements, when a train stops to be met or passed by a continuous welded rail train, the CWR train must also be inspected to determine rails are in position in the roller racks, that ends of continuous rails are not closer than 12 feet from the next empty roller and that they overhang the last supporting roller by at least 12 feet, and to see that cars are properly coupled with locking devices in place.

RULE 834. Loaded multi-level cars in other than solid trains must be entrained at least four cars behind working locomotives in road movement; also loaded multi-level cars must not be entrained next to hopper, gondola or tank cars loaded with stone, gravel, sand, lime, coal, soda ash, chemicals, etc., subject to wind, vapor, or fume action on adjacent cars, nor placed next to empty cars previously loaded with such commodities. Loaded multi-level cars must not be entrained next to open-top loads of lumber, poles, steel, etc., when lading extends beyond top of car.

Open-top cars with lading height exceeding 15 feet six inches, except cars transporting highway trucks or trailers, multi-level freight cars either loaded or unloaded, and automobile underframe cars, shall be entrained at least five cars distance from engine or caboose if length of train permits on train operating in or through the States of California, Nevada and Arizona.

Additionally, in California, wood chip cars transporting wood chips when loaded and covered in such a manner so as to preclude any material from being dislodged enroute, are exempted from restrictions above.

RULE 874. Forward brakeman on freight trains will ride the lead unit when a seat is available.

RAILROAD RADIO RULES GENERAL

RULES 950, 950-A, 950-B, 951, 952, 953, 954, 955, 956, 957, 958, 959, 960, 961, 963, 964, 965, 966, and 967 are cancelled and following new radio rules are in effect:

RULE 950. Following rules and requirements cover use of railroad radio systems and govern employes using such systems.

RULE 950-A. A railroad radio communication system is one employing radio for the transmission of intelligence between moving equipment, between moving equipment and a fixed point, or between fixed points.

RULE 950-B. Radio communications systems are under the jurisdiction of the Federal Communications Commission. The Railroad Company and its employes are governed by the Commission's operating rules including those incorporated herein. Violation is a Federal offense for which severe penalties are provided.

RULE 950-C. The locations of radio base and wayside stations, times such stations are attended, and assigned channels will be designated by timetable or other instructions.

RULE 950-D. When radios are manned, they must be turned on to the appropriate channel with volume adjusted to receive communications. When radios are not manned or when employes are not in position to receive radio calls, battery-operated radios must be turned off.

RULE 951. Only employes specifically authorized to do so by the FCC are permitted to make any internal adjustments to a railroad radio. Authorized employes must carry their FCC operator license or verification card when on duty. If it appears that a radio transmitter is not operating properly its use shall be discontinued and the designated official notified as soon as possible.

The designated railroad official will be named in notice posted in cab of engine, in caboose or in the base station.

RULE 952. No employe shall knowingly transmit any false emergency communication, any unnecessary, irrelevant or unidentified communication, nor utter any obscene, indecent, or profane language via radio.

RULE 953. No employe shall divulge or publish the existence, contents, purport, effect or meaning of any communication (emergency communications excluded) except to the person for whom the communication is intended or to another employe of the railroad whose duties may require knowledge of the communication. The above applies either to communications received directly or to any that may be intercepted.

RULE 954. Before transmitting, any employe operating a radio transmitting set shall listen a sufficient interval to be sure that the circuit is not already in use, particularly for emergency traffic.

When a train order is being transmitted to a train by radio, employes not addressed shall not use the radio, except in case of emergency, until the train order has been completed.

RULE 955. An emergency call must be preceded by the word "Emergency" repeated three times. Such calls must be used only to cover initial reports of derailments, collisions, storms, washouts, fires, obstructions to track, or other matters which would cause serious delay to traffic, damage to property, injury to employes or the traveling public, and contain as complete information thereon as possible. All employes must give absolute priority to emergency calls from another station and, except in answering or aiding a station during an emergency, must refrain from sending any communication until there is assurance that no interference will result to the station initiating emergency calls.

RULE 956. The railroad company is required to answer an official notice of violation of the terms of the Communications Act of 1934, as amended, within ten days from receipt of notice and any employe receiving inquiry concerning any violation shall answer such inquiry within 48 hours after receipt of notice.

RULE 957. Employes must permit inspection of the radio equipment in their charge and all FCC documents pertaining thereto, by a duly accredited representative of the Federal Communications Commission at any reasonable time.

RULE 958. An employe transmitting or acknowledging a radio communication must begin with positive identification which must include the following in the order listed:

- (a) Base or wayside stations.
 1. Name or initials of the railroad.
 2. Name of office or other unique designation and the name and location of the station.
- (b) Mobile units.
 1. Name or initials of the railroad.
 2. Train name (number), engine number, location, or words that identify the precise mobile unit.

EXAMPLE: "SP Caboose Train Second 802 calling SP Engine Second 802, over" and to answer a call, announce, for example: "This is SP Engine, Train Second 802, over."

In all yard operations, after initial positive identification is established, short identification may be used.

Station identification must be repeated at the end of any transmission exceeding three minutes in length. If an exchange of communication continues without substantial interruption, positive identification must be repeated each 15 minutes.

In radio transmissions, if necessary for clarity when using letters, words or numerals, be governed by Rule 206 for spelling or pronunciation.

RULE 959. In certain cases at crossings, junctions or paralleling tracks some interference may develop with another railroad. In such cases special care in making identification shall be used and the employes concerned shall co-operate in handling their business by alternating calls and being as brief as possible.

RULE 960. If any communication from a station other than another railroad radio station interferes with railroad radio service, the railroad employe will endeavor to ascertain the identity of such station. Employe will report the occurrence as soon as possible through authorized channels to the designated railroad official, giving the exact time, nature of communication and identity of the station, if possible.

Internationally, the word "Mayday" indicates a distress message, the word "Pan," an urgent message and the word "Security," a safety message. Railroad employes may hear such messages sent by aircraft or, by boats in coastal areas. Railroad employes hearing such messages must report them immediately through authorized channels to the designated railroad official in addition to taking such appropriate action to relieve the distress as may be possible.

RULE 961. The radio must be used only in connection with railroad business and in compliance with the operating rules.

Except for emergency situations, radio transmitter must not be used within 500 feet of a Hot Box Detector scanner site.

RULE 963. RADIO COMMUNICATION, IF DISTINCT, MAY BE USED THE SAME AS ANY OTHER MEANS OF COMMUNICATION, including usage as follows:

- (a) Operator communicating direct with member of crew, after assured train is stopped, may authorize train to pass an interlocking signal displaying stop indication, as prescribed by Rule 663(b).
- (b) Operator communicating direct with member of crew may authorize train to make reverse or forward movement within interlocking limits as prescribed by Rule 670 when no interlocking signal is provided to authorize movement.
- (c) Operator communicating direct with engineer may authorize train to proceed under provisions of Rule 211.
- (d) Train dispatcher communicating direct with member of crew after assured train is stopped, may authorize train to pass an absolute signal displaying stop indication within CTC limits as prescribed by Rule 776. **EXCEPTION:** Refer to Rule 783.
- (e) Train dispatcher communicating direct with member of crew may designate work limits and clock time limit as prescribed by Rules 765 and 767.

RULE 964. Radio communication, if distinct, may be used to transmit and receive track car time and movement limits under provisions of Rule 766-A, or line-up of trains for track car operators. Radio communication, when distinct, may also be used by MofW&S foremen to receive and release work limits and clock time limit under provisions of Rules 766 and 767.

RULE 965. Radio communication, when distinct, may also be used as herein provided:

- (a) Train dispatcher may transmit train order to train-order operator as prescribed by Rule 206-A.
- (b) Train-order operator may relay train order as prescribed by Rule 206-C.
- (c) After assured train is stopped, train order may be transmitted to conductor or engineer or designated employe promoted to conductor or engineer as prescribed by Rule 208-B.

The information contained in train orders shall not be acted upon by other than those to whom the train orders are addressed.

Except as provided in paragraph (c) and in Rule 211, train dispatcher and train-order operator must not use radio to inform enginemen or trainmen as to the contents of any train order. Operator may advise approaching train when he holds restricting order addressed to that train.

RULE 967. Enginemen or trainmen must not request train-order operator to advise indication of train-order signal. Train-order operator must not furnish this information.

RULE 968. An employe receiving a radio call must not delay acknowledgment unless it would interfere with duties relating to safety.

RULE 969. An employe who receives a transmission must repeat it to the transmitting party except when the communication:

- (a) Relates to yard switching operations;
- (b) Is a recorded message from an automatic alarm device; or
- (c) Is general in nature and does not contain any information, instruction or advice which could affect the safety of a railroad operation.

RULE 970. To indicate that a transmission is ended and that a response is expected, the transmitting employe must say "over." To indicate that a transmission is ended and that no response is expected, the transmitting employe must state his identification and say "out."

RULE 971. Radios used in train operation outside yards must be tested at the point where the train is originally made up.

During each tour of duty, engineers and conductors must check to see that engine and caboose radios are working.

Radio check must consist of an exchange of voice communication with another radio, determining quality and readability of transmission.

A malfunctioning radio must not be used and each crew member and the train dispatcher or other designated employe must be so notified as soon as practicable.

RULE 972. Except between members of the same crew, no information may be given by radio to a train or engine crew about the aspect of a fixed signal.

Unless specifically authorized by operating rules, radio must not be used to convey instructions which would override the indication of a fixed signal.

RULE 973. The use of citizen band radios for railroad operating purposes is prohibited.

RULE 974. When radio is used to transmit train orders, rules for movement by train order and the following instructions apply:

- (a) When a train order is to be transmitted directly to a train by radio, the train dispatcher will call the train and state this fact. The crew members who are to copy the order must state their names, positive identification and exact location and that they understand a train order is to be transmitted and that they are prepared to receive it.

SPECIAL INSTRUCTIONS—ALL SUBDIVISIONS

- (b) Train orders transmitted shall be copied in the prescribed form by the employe receiving order. After the conductor and engineer have both made or received written copy of the train order and, unless copied in manifold, have repeated it to each other, employe who received order from train dispatcher or operator shall then repeat order to dispatcher or operator.
- (c) "Complete" must not be given to a radio-transmitted train order until it has been repeated and dispatcher has verified the accuracy of the repetition. Dispatcher will then state "Complete," the time, and the initials of the Chief Train Dispatcher. Crew members copying the order must then acknowledge by repeating "Complete" and the time.
- (d) "Complete" and time must not be given to a radio-transmitted train order for an inferior train until response "Complete" and time have been acknowledged by the superior train.
- (e) Train orders transmitted by radio directly to two or more trains must be transmitted simultaneously to as many of them as practicable.
- (f) Radio communication must not be used to inform a train of the contents of a train order not yet transmitted to or received by that train.

AIR BRAKE RULES

RULE 3. A full independent brake application on road engine classes EP636, GF628, EF630, EF636, EF642, GF630, GF633, and EF623 results in a brake cylinder pressure of 72 lbs. This brake cylinder pressure must be maintained to provide required braking power at very low speeds or when stopped. Under no circumstances must self-lapping portion of independent brake valve be changed except to obtain brake cylinder pressure of 72 lbs. from a full independent brake application.

RULE 9. The following series of cars are equipped with ABEL brake system which has automatic change-over feature to provide proper brake function when car is loaded and when empty:

SSW 75700-75799	Gondolas
SSW 78500-78599	Hoppers (Open Top)
SP 333500-334399	Gondolas
SP 337500-337599	Gondolas
SP 345000-345669	Gondolas
SP 354000-354749	Gondolas
SP 463500-464899	Hoppers (Open Top)
SP 467500-467549	Hoppers (Open Top)
SP 480000-480193	Hoppers (Open Top)
SP 491000-491059	Hoppers (Covered)
SP 492000-492039	Hoppers (Covered)
SP 500604	Flat Car
SP 590000-590099	Flat Cars

The following series of cars are equipped with ABDEL brake system, which has automatic change-over feature to provide proper brake function when car is loaded and when empty. This feature is fully automatic on these series and requires no action on part of engineer:

SP 337600-337699	Gondolas
SP 354750-355299	Gondolas
SP 463337-463486	Hoppers (Open Top)
SP 464000-465699	Hoppers (Open Top)
SP 590100-590131	Flat Cars (Anode)
SP 595500-595624	Cradle Flats

RULE 17. When dynamic brakes are not used on helper engine(s), tonnage of such engine(s) must be added to that of train in determining the number of retaining valves required.

RULE 26. When temperature is 32 degrees or less, running test may be made (Rule 25-A) in lieu of last paragraph of Air Brake Rule 26.

If unable to obtain proper air brake test while running, train must be stopped and air brake hose on head end blown out as prescribed in last paragraph Air Brake Rule 26.

RULE 27. First paragraph is revised to read:

Refer to Rule 102 of the Rules and Regulations of the Transportation Department regarding procedures when a train or engine with a cut of cars, in motion, on main track or siding has an emergency application of air brakes.

RULE 33. Following trains RVOGP, RVNPP, FRRVP and BKRVP containing not less than 90 percent mechanical refrigerator cars or any restricted cars, not exceeding 120 cars and/or 90 tons per operative brake may be authorized by train order to operate at Column 1 speeds not exceeding 65 MPH unless otherwise restricted.

When speed is to be restricted to 45 MPH by Air Brake Rule 33 account tonnage exceeding 80 tons per operative brake, the following trains: UPSFF, UPSFT, LABRT, LABRF, BRLAT, BROAT, OABRT, OAOGF when consisting of not more than 50% multi-level equipment may be authorized, by train order, to operate at maximum speed otherwise allowed but not exceeding speed shown in following table:

Number of cars	TONS PER OPERATIVE BRAKE	
	between 80 and 85	between 85 and 90
1 to 50	70 MPH	65 MPH
51 to 60	65 MPH	65 MPH
61 to 65	65 MPH	55 MPH
65 to 70	60 MPH
71 to 80	50 MPH

In all other cases not covered in the above table Air Brake Rule 33 will apply.

Speed restrictions in grade territories in excess of 1.8% designated by Superintendent under subdivisions must be complied with.

MISCELLANEOUS

1. HELPER SERVICE:

The following covers engine tractive effort in pounds:

Engine Model	Classification	Starting Tractive Effort
C 415	AS415	62,750
RS 11	AS418-1 to 6	65,000
RS 32	AS420	63,750
C 630	AS600-1	102,000
RSD 15	AS624-1	92,500
C 628	AS628-2	97,750
C 630	AS630-1	101,000
GP 9	EF418-1 to 9; EF418C-1-2; EF418E-1-2-3	64,200
GP 20	EF420-1-2; EF420C-1-2	65,100
GP 30	EF423-1; EF423C-1	66,100
GP 35	EF425-1 to 4; EF425C-1-2-3	66,000
GP 40	EF430C-1	67,560
SD 9	EF618-1 to 5; EF618E-1-2	89,700
SD 39	EF623-1-2	104,150
SD 35	EF625-1	95,540
SD 40	EF630-1-2	102,750
SD 40-2	EF630-3-4	102,100
SD 45	EF636-1 to 6; EF636C-1 to 5	103,470
SD 45-2	EF636-7 to 10-12-15; EF636C-6 to 9	102,600
SD 45X	EF642-1-2	103,240
DD 35	EF850B-1	131,750
GP 40P-2	EP430-1	70,200
SDP 45	EP636-1	102,500
SW 1200	ES412	62,250
SW 1500	ES415-1 to 6	65,000
MP 15	ES415-7	65,400
SD 7	ES615-1 to 4	82,500
SD 38	ES620-1	104,000
U 25 B	GF425-1-2-3	67,800
U 28 B	GF428-1	67,890
U 28 C	GF628-1	103,120
U 30 C	GF630-1-2	104,850
U 33 C	GF633-1 to 10	104,710
U 50	GF850	139,250

NOTE: For classification of engines, see Item 3.

A. Rule for entraining one helper engine:

- (1) On trains of less than 100 cars, helper engine consisting of not more than two six-axle operating units totaling 179,400 pounds tractive effort nor more than two four-axle operating units totaling 135,600 pounds tractive effort or a combination of one four-axle and one six-axle operating unit totaling 157,600 pounds tractive effort may be placed behind caboose.
- (2) On trains of 100 or more cars helper engine consisting of only one unit may be placed behind caboose.
- (3) Helper engine that does not qualify under (1) or (2) must be entrained as near as practicable to shove 1/3 and pull 2/3 of tonnage handled by helper engine.

B. Rule for entraining more than one helper engine:

- (1) Trains having more than one helper engine must have each engine entrained as near as practicable so that it will shove 1/3 and pull 2/3 of tonnage handled.
- (2) Trains powered with two helper engines, one of which qualifies to be placed behind caboose, must entrain the swing helper as near as practicable to shove 1/3 and pull 2/3 of tonnage handled by the swing helper.

C. Air must be cut in on all helper engines and engine must not be coupled nor uncoupled while train is in motion.

D. Road engineer and helper engineer must communicate any change affecting the operation of their train when means of communication is available. When speed is being held above 8 MPH on ascending grade, helper engineer must regulate amperage during speed reductions or speed increases to maintain the amperage indicated before speed change; if speed of train drops below 8 MPH or when coming to a stop on ascending grade, helper engineer must regulate amperage during speed reduction to maintain the amperage indicated before speed change, then close throttle just before train stops.

E. When speed of trains powered with 12,000 or more horsepower on the head end and with helper engine drops below 16 MPH, road engineer must reduce throttle to Run 6.

When train speed drops below 16 MPH, head end power being reduced to Run 6 may result in helper power working in short time rating. The short time rating must not be exceeded. If it appears that short time rating will be exceeded, assistance must be requested from train dispatcher. If assistance cannot be obtained, grade must be doubled.

F. Trailing tonnage must not exceed that amount of tonnage listed under column "Maximum Tonnage to be Handled by Road Engine With Helper Entrained" for territory over which helper will be used. Should the amount of tonnage computed exceed the maximum tonnage listed, it may be necessary to isolate road units or add helper power. If practical, isolate units behind the lead unit leaving operating units next to the train. Weight of those units isolated and separated from the train by operating units need not be added to train weight in computing location of helper.

If units have to be isolated next to the train, weight of these units must be added to the train when computing location of the helper.

If units are moved dead in consist, they should be placed next to the train and their weight added to the tonnage of the train.

UNLESS OTHERWISE RESTRICTED MAXIMUM TONNAGE TO BE HANDLED BY ROAD ENGINES WITH HELPERS ENTRAINED:

TERRITORY

Roseville-Colfax (E).....	6,500
Colfax-Norden (E).....	3,900
Sparks-Truckee (W).....	6,500
Truckee-Norden (W).....	4,500
Wells-Moor (E).....	7,500
Lucin-Valley Pass (W).....	8,000
Delta-Dunsmuir (E).....	7,500

UNLESS OTHERWISE RESTRICTED MAXIMUM TONNAGE TO BE HANDLED BEHIND HELPER ENGINES:

TERRITORY

Roseville-Colfax (E).....	5,525
Colfax-Norden (E).....	3,315
Sparks-Truckee (W).....	5,525
Truckee-Norden (W).....	3,825
Wells-Moor (E).....	6,375
Lucin-Valley Pass (W).....	6,800
Delta-Dunsmuir (E).....	3,812

G. In locating helper engine(s) in train, the following example of calculating tonnage for road engine and helper engine(s) will be used:

EXAMPLE:

Train: 42 loads, 87 empties = 5756 tons.
 Four-unit road engine (2-GF630, 1-EF623, 1-EF625).
 Three-unit helper engine (2-EF623, 1-EF630).

Total road horsepower	10800
Total helper horsepower	7600
Total horsepower	18400

(1) Divide total horsepower by tonnage =

$$\frac{18400}{5756} = 3.196 \text{ HP/T}$$

(2) Divide road horsepower by HP/T factor =

$$\frac{10800}{3.196} = 3379 \text{ tons}$$
 Road engine will handle 3379 tons

(3) Divide helper horsepower by HP/T factor =

$$\frac{7600}{3.196} = 2377 \text{ tons}$$

(4) To determine 1/3 of helper tonnage divide

$$\frac{2377}{3} = 792 \text{ tons}$$

Helper engine will shove 792 tons.

(5) To determine 2/3 of helper tonnage multiply 792 x 2 = 1584 tons
 Helper engine will pull 1584 tons.

(6) Under no circumstances should the tonnage that will trail the helper engine exceed that amount indicated in the chart.

(7) Should tonnage trailing road or helper engine, as computed above, exceed the amount indicated in the chart it will be necessary to:

- (a) Reduce tonnage or
- (b) Relocate helper in compliance with instructions. (Item D under General) or,
- (c) Add additional helper(s) of sufficient horsepower to handle tonnage in excess of amounts indicated in chart. Additional helper(s) may be placed behind caboose if they meet requirements of item A 1., if not they are to be entrained as follows:

SPECIAL INSTRUCTIONS—ALL SUBDIVISIONS

EXAMPLE:

Train: 170 loads, 2 empties = 13,980 tons
 Three-unit road engine (1-EF630, 1-EF636, 1-GF633)
 Four-unit swing helper (1-EF630, 2-EF636, 1-GF633)
 Two-unit rear helper (1-EF618, 1-EF630)

Total road horsepower	9900
Total swing helper horsepower	13500
Total rear helper horsepower	4800

Total horsepower 28200

(1) Divide total horsepower by tonnage =

$$\frac{28200}{13980} = 2.017 \text{ HP/T}$$

(2) Divide road horsepower by HP/T factor =

$$\frac{9900}{2.017} = 4908 \text{ tons}$$

Road engine will handle 4908 tons

(3) Divide swing helper horsepower by HP/T factor = 13500

$$\frac{13500}{2.017} = 6693 \text{ tons}$$

Swing helper will handle 6693 tons (total)

(4) To determine 1/3 of swing helper tonnage =

$$\frac{6693}{3} = 2231 \text{ tons}$$

Swing helper will shove 2231 tons

(5) To determine 2/3 of swing helper tonnage =

$$2231 \times 2 = 4462 \text{ tons}$$

 Swing helper will pull 4462 tons

(6) Divide rear helper horsepower by HP/T factor = 4800

$$\frac{4800}{2.017} = 2380 \text{ tons}$$

Rear helper will handle 2380 tons (total)

(7) To determine 1/3 of rear helper tonnage =

$$\frac{2380}{3} = 793 \text{ tons}$$

Rear helper will shove 793 tons.

(8) To determine 2/3 of rear helper tonnage =

$$793 \times 2 = 1586 \text{ tons}$$

Rear helper will pull 1586 tons.

GENERAL:

- A. At locations designated by the Superintendent, road power must not exceed 24 axles of operative power.
- B. Helper engine must not be placed on head end of train without authority being obtained from train dispatcher.
- C. AS415, AS420, ES412 and ES415 class, except ES415 class numbers 2680-2759 units must not be cut into train in helper service. ES415 class numbers 2400-2679 may be cut into train and used in helper service providing coupler stops are applied and locked on both ends of the engine. No more than two of these units may be placed behind the caboose.
- D. Should it become necessary to relocate the helper at other than the shove 1/3, pull 2/3 location in order to separate helper from restrictive cars or in compliance with maximum tonnage trailing helper limitations, the helper may be relocated, but under no circumstances in relocations may helper shove less than 30% nor more than 45% of the total tonnage to be handled by the helper.
- E. When helper is used on train handling empty coil cars in series SP 595500 to SP 595624, helper engine must be entrained ahead of these cars.

2. PLACEMENT OF RESTRICTED CARS IN TRAIN WITH OR WITHOUT HELPER:

- (a) Between Roseville and Dunsmuir and Roseville and Sparks, empty 70-foot-long or longer equipment must be entrained ten or more cars behind road engine and ten or more cars ahead of helper engine. A flat car with one van or one container, whether loaded or empty, must be considered as an empty. These instructions will not apply to trains BRLAT, BROAT, LABRF, LABRT, OABRT, OAOGF, OAOGH, OAOGJ, RGSFF, RVNPE, UPSFF or UPSFT.
- (b) When average weight of cars in train, other than locals or switchers, is more than 60 tons per car, do not handle any cars which weigh less than 50 tons within five cars of road engine. These instructions will not apply to continuous welded rail (CWR) trains nor to trains operating between Roseville and Oakland via Davis, to trains OAOGF, UPSFF, and UPSFT operating between Ogden and Roseville, or to WPRR trains FF, GGV, B-PBF and OMW operating between Weso and Alazon.
- (c) Following series of USAX or DODX cars are restricted to movement on rear of train and behind any helper engines:

38016 thru 38666 and
39095 thru 39199

Restricted cars will be indicated on conductor's train list at terminals. When cars listed in above series are picked up at locations other than terminal, they must be entrained on rear of train and behind any helper engine, unless it is determined that cars are not restricted.

- (d) Cars measuring less than 35 feet over coupler pulling faces must not be handled in train coupled to cars longer than 60 feet over coupler pulling faces.

In addition, empty tank cars under 35 feet outside length will be entrained within 20 rear cars of train.

Either the Train Mass Profile (graph), conductor's train list and/or switch list furnished crew members will identify a car measuring less than 35 feet over coupler pulling faces with letter "S," tank cars with the letters "TS." Cars measuring over 60 feet between coupler pulling faces will be identified by the letter "L."

3. CLASSIFICATIONS ARE DESCRIPTIVE OF ENGINES AS FOLLOWS:

E F 4 15 A C 01

Denotes Order of Purchase for Units of same Classification.

Denotes Ownership if other than SPT Co.:
C = SSW Ownership.

E = SP Equipment Co. owned, leased to SPT Co.

S = SP Equipment Co. owned, leased to SSW Ry.

Denotes Car Body Type with Control Cab;
B = Booster; No Letter = Road Switcher Type.

Denotes Horsepower in Hundreds: 00 = Not Powered;
18 = 1750-1800 HP, etc.

Denotes Number of Axles.

Denotes Service Assignment: F = Freight; M = Misc.;
P = Passenger; S = Switcher.

Denotes Builder: A = Alco; E = EMD; G = GE; S = SPT.

4. SPEED RESTRICTIONS FOR ENGINES: Maximum speed shown below is subject to further restriction applicable to certain territories as shown in Speed Restrictions for Trains:

MAXIMUM SPEED AND LENGTH OF ENGINES
(Between pulling face of couplers)

CLASSIFICATION	ENGINE NUMBERS	MAXIMUM SPEED EXCEPT #	LENGTH (FEET)
AS600	1000-1002	70	70
ES406	1004	45	44
ES408	1100-1128	65	44
ES408B	1150-1153	65	44
ES409	1190-1199	65	44
AS409	1200-1281	60	45
ES410	1300-1337	65	44
ES615	1400-1442	70	61
ES412	2250-2316	65	44
AS415	2400-2409	65	54
ES415	2450-2689	65	45
ES415	2690-2759	65	48
AS418	2900-2903; 2905-2936	70	57
AS618	2951-2970	70	58
ES620	2971-2976	50	69
EP418	3001-3002; 3004-3010	70	56
AS624	3100-3102	25*	67
AS628	3110-3136	25*	69
AS630	3140-3153	25*	69
EP418	3186-3196	70	56
EP430	3197-3199	70	63
EP636	3200-3209	70	71
EF418	3300-3857	70	56
EF618	3870	70	61
EF418	3871-3873	70	56
EF618	3873-3875	70	61
EF418	3877-3883	70	56
EF618	3893	70	56
EF618	3902-3964	70	61
AS420	4000-4009	70	57
EF420	4030-4153; 4500-4553; 4560-4576	70	56
EF618	4300-4451	70	61
EF620	4700-4724	70	61
EF423	5000-5037	70	56
GS407	5100-5109	55	37
EF623	5300-5325	70	66
EF425	6300-6303	70	56
EF425	6500-6681	70	56
GF425	6700-6767; 6800-6865	70	60
EF625	6900-6953	70	61
GF428	7025-7028; 7030-7033	70	60
GF628	7150-7159	70	67
EF435	7200-7201; 7230-7231	70	60
EF430	7600-7607	70	59
GF430	7800-7803	70	62
GF630	7900-7936	70	67
EF630	8300-8306; 8350-8356	70	71
EF630	8400-8488	70	66
GF633	8585-8796	70	67
EF636	8800-9156	70	66
EF636	9157-9404	70**	71
	**Except: 9213, 9219, 9228, 9237, 9241, 9242, and 9246 restricted to 50 MPH.		
EF642	9500-9505	70	71
EF850B	9900-9902	70	88
GF850	9950-9952	70	84
	AMTRAK ENGINES:		
EP415A	Model F7, 110-123; 376-377	79	51
EP430A	Model F40PH, 200-229	70	56
EP630A	Model SDP40F, 500-649	70	72
GP630A	Model P30CH, 700-724	70	72
	BN ENGINES:		
EF630	6800-6807	70	71
	D&RGW ENGINES:		
EF423	3001-3028	70	56
EF425	3029-3050	70	56
EF430	3051-3128	70	59
EF636	5315-5340	70	66
EF630	5341-5385	50	71

CLASSIFICATION	ENGINE NUMBERS	MAXIMUM SPEED EXCEPT —	LENGTH (FEET)
	UP ENGINES:		
GF628	2800-2809	70	65
GF630	2810-2919	70	67
EF630	3000-3122	70	66
EF630	3123-3304; 3335-3399	50	71
EF636	3600-3649	70	66
EF630	8000-8074	50	71
	SN ENGINES:		
SW-1	401-402	30	44
GP-7	711-712	65	56
NW-2	607	30	44

WP ENGINES:

Engine Numbers	Running Forward With Train or Light	Running Backward With Train or Light***	Length (Feet)
601-608	30	30	44
701-713; 725-732	65	60	56
1501-1503	65	45	45
2001-2010	70	60	56
2251-2265	70	60	60
3001-3022	70	60	56
3051-3071	70	60	60
3501-3544	70	60	59

***When operated in multiple unit control with engineer in other than lead unit in direction of movement must not exceed 30 MPH.

SNRY and CCT engines will not exceed speed restrictions for engines shown in SNRY and CCT timetables and maximum speed is subject to further restrictions applicable to certain territories as shown in speed restrictions for trains.

Engines handled dead must not exceed speed shown in table.

#When operated in multiple unit control, on head end of train or running light and engineer is in other than the leading control cab in direction of movement, speed must not exceed 30 MPH. 'A' type units (indicated by letter 'A' following classification numerals) operating in reverse as lead unit in direction of movement must not exceed 30 MPH.

*May be handled isolated in multiple, dead in multiple, or dead in train at maximum speed of 70 MPH.

Any locomotive not listed in these tables is not to be operated in trains unless authorized by train order indicating maximum permissible speed for locomotive which is then subject to any further restrictions imposed by the timetable or otherwise.

5. MOVEMENT OF LOCOMOTIVES

RULES GOVERNING MOVEMENT OF ENGINES NOT EQUIPPED WITH ALIGNMENT CONTROL COUPLERS

- AS415, AS420, ES415, and following ES412 (2266, 2271, 2272, 2275, 2276, 2279, 2282, 2283, 2284, 2285, 2286, 2287, 2288) class engines must if practicable, be MU'd in accordance with rules. These engines are equipped with dynamic brake wire.
- When necessary to entrain the following class engines:

ES406	ES409	ES410	ES412E
AS407	AS409	ES412	ES415*
ES408	ES410E	FS412	AS415
ES408B	AS410	GS407	AS420

Placement in train will be as follows:

- Foreign line engines not equipped with alignment control couplers are to be considered in above listings.
- Engines moved dead in train must be prepared for such movement.
- These engines may be moved on the head end of train, provided train does not exceed 800 tons.

- d. On trains of more than 800 tons, these engines must be moved not less than 5 cars nor more than 10 cars ahead of rear of train and behind any helper engine.
- e. Not more than two of these engines may be moved in a train and when two are moved they must be separated by a car no longer than 50 feet.
3. When only AS415, AS420, ES412 and ES415* units are used in engine consist, not more than two units may be on the line when making a reverse movement with cars or train and on line units must be located adjacent to the train.
4. One AS415, AS420, ES412 and ES415* unit may be MU'd on the head end of one road unit.
5. When a train being handled by a single unit road engine where no dynamic braking is required or reverse movements will be made, a single AS415, AS420, ES412 and ES415* unit may be placed next to the train.
6. When operating with mixed engine consist, where dynamic braking is required, not more than two AS415, AS420, ES415* and following ES412 units will be used:
- | | | |
|------|------|------|
| 2266 | 2279 | 2286 |
| 2271 | 2282 | 2287 |
| 2272 | 2283 | 2288 |
| 2275 | 2284 | |
| 2276 | 2285 | |
- a. If one unit is used it will be placed as second unit in engine consist.
- b. If two units are used, they will be placed as second unit and third units in engine consist.
- c. A road unit must be coupled against the train.
- d. If necessary to make a reverse move with cars or train, lead unit must be isolated.
7. If necessary to operate with more than two AS415, AS420, ES412 and ES415* class units in consist (including pick up of units from outlying points), these units must be placed in the lead. If reverse move is made with cars or train, all units ahead of the two rear units in these classes will be isolated.
8. Extreme caution must be used during dynamic braking or when making reverse moves to prevent jackknifing and track damage.

ENGINES EQUIPPED WITH ALIGNMENT CONTROL COUPLERS

* Class ES415, Nos. 2680-2759 are equipped with alignment control couplers in buff and may be MU'd in Engine consist without regard to location. These engines may be moved dead on the head end of train.

Engines equipped with multiple unit controls (MU) and alignment control couplers, weighing 150,000 pounds or more, may be handled on head end of train; if weighing less than 150,000 pounds, must be placed near rear of train in accordance with Item 5.

INSTRUCTIONS FOR USE OF HINGED COUPLER STOPS

For use in switching service the coupler stops must be opened (swung back) against end of engine and locking pin secured in bracket provided.

For use in road service, MU service, or dead in train, the coupler stops must be closed (swung in) into coupler opening against coupler pocket side with locking pin secured behind coupler carrier on both ends of engine.

Locking pins must be in place (whether coupler stop is swung back or swung in) to insure securement of the coupler stop.

With the coupler stops in place, these engines may be MU'd in engine consist without regard to location, or may be moved dead on head of train.

Class ES415, Nos. 2450-2679 are equipped with hinged coupler stops.

PREPARATION OF AIR EQUIPMENT FOR MOVEMENT DEAD IN TRAIN

ALL UNITS:

Reduce main reservoir pressure to 25 lbs. above zero.

Cut in dead engine feature.

Remove automatic brake valve handle in running position or with 26-L equipment, remove in handle off position.

If brake valve handles cannot be removed, they must be blocked in running position.

IN ADDITION:

24 RL equipment:

Close brake pipe cut-out cock and place the dual ported cut-out cock in cut in position.

Open the end cocks on actuating pipe and independent application and release pipe.

6 SL or 14 EL Equipment.

Close the brake pipe cut out cock, or place the rotair valve or 3 position brake pipe cut out cock in dead position.

26 L Equipment.

Place the brake pipe cut off valve in cut-out position.

Place the dual ported cut-out cock in open or cut in position, or place the MU 2a valve in lead or dead position.

Open the end cocks on actuating pipe and brake cylinder equalizing pipe.

6. Dead or disabled engines, and equipment listed in timetable which requires movement at reduced speed must first be reported as ready to move to the Chief Train Dispatcher, who will designate the train in which the engine or equipment is to be moved. Any such engine must not be handled in train until train order designating maximum speed is issued.

7. Engines operated with engineer in other than lead unit in direction of movement, must not exceed 20 MPH when approaching highway or street crossing at grade, subject to further restrictions imposed by local conditions.

8. When a unit or units in locomotive consist emit excessive smoke through exhaust stacks other than from a cold start, prompt report must be made to train dispatcher who will arrange to notify roundhouse foreman or locomotive maintenance forces on duty at first maintenance facility where train is scheduled to stop. Unit number, time and location where excessive smoking of unit was first observed must be reported.

When a yard engine is observed emitting excessive smoke, report must be made to roundhouse foreman or locomotive maintenance forces on duty.

In addition, engineer must make appropriate entry on work report, Form CS 2326.

9. Not more than 10 diesel units in operation may be used on head end of any freight train.

10. Unless otherwise authorized, trains handling passenger cars with flat spots on wheels in excess of 3¼ inches in length must not exceed 10 MPH. When flat spots are not in excess of 3¼ inches long such cars may be operated at maximum authorized speeds.

11. Gross weight of SPMW 6400-6439 100-ton air dump cars cannot exceed the gross weight shown in On Line Clearance Circular for each branch line. Also, cars must not be dumped on curves of 25 degrees or more, or operated through curves of 35 degrees or more.

12. Except when handling cabooses on or near the head end in local or road switcher service when handling only a few cars, cabooses are not to be moved other than at rear of train, unless specifically authorized.

13. When setting out bad order cars enroute, head portion of train, together with bad order car, must be taken to the nearest set out point in direction of movement, bad order car set out, engine detached and head portion of train left at set out point, when practicable. Rear portion of train is then to be brought to set out point and head and rear portions of train coupled together.

14. LOAD LIMIT

Where 315,000 pound load limit applies:

Gross weight of 315,000 pounds applies to uniformly loaded four-axle cars with minimum axle spacing of 6'-0" and minimum distance of 37'-0" center to center of trucks; also wheels 38" or more in diameter.

FMLX tank cars, 19000-19023, and GATX tank cars, 94050-94054 and 94056-94092, which are equipped with 34'-8" truck centers may operate from Ogden to Newark with no more than two such cars coupled together.

Where 263,000 pound load limit applies:

Gross weight of 263,000 pounds or less applies to uniformly loaded four-axle cars having trucks spaced 23'-0" or more center to center and minimum axle spacing of 5'-6".

15. Units SSW 9052 through 9068 and 9090 through 9110 will have overspeed cut-out cocks blocked open and no attempt should be made to close them. In event overspeed device (or speedometer) malfunctions enroute, unit should be rearranged in the locomotive consist as a train-line unit to clear the condition.

16. Trailer flat cars, tri-level automobile carrying cars and 30,000-gallon "Super Tanker" tank cars, all 80 and 85 feet long. "Jumbo" tank cars HYDX 701 to 706, inclusive, loaded or empty, without authority of Chief Train Dispatcher must not be operated on any branch, on west leg of wye at Chico, or on industry, yard tracks, or interchange tracks within Sacramento yard limits. These cars can be operated on 12th St. yard tracks, new yard, 6th St. yard, levee tracks, freight leads, back leads and Depot No. 1, in Sacramento.

17. SNOW SERVICE:

- (1) Rotary snow plow will not clear certain structures, tunnels and cuts with wings extended; be governed by instructions posted in rotary cab.
- (2) Rotary snow plows must be stopped with wings in closed position when a train or engine is passing on adjoining track.
- (3) Flangers operating in snow territory must raise flanger blades and stop while train or engine is passing on adjacent track.

Maximum speed for flangers is 40 MPH.

MAXIMUM SPEED PERMITTED WITH CERTAIN EQUIPMENT	MPH MAIN TRACKS OTHER THAN BRANCHES	MPH MAIN TRACKS ON BRANCHES
	able counterweight properly positioned, either end forward.....	55
SPMW 4028, 4029, SSW 96405:		
With boom in place, either end forward①.....	25*	15*
With boom disconnected, heavy end forward.....	40	25
boom end forward.....	20*	15*
With boom disconnected and removable counterweight properly positioned, either end forward.....	40	25
SPMW 4027 SPMW 5870		
4038 5874		
4091 5899		
5437 6601		
5479 6602		
5595 SSW 96404		
5852 NWPMW 31		
With boom in place, either end forward①.....	25*	15*
With boom disconnected, heavy end forward.....	45	25
boom end forward.....	20*	15*
Steam pile driver SPMW 4053.....	35	25*
Jordan Spreaders:		
Running backward.....	25	20
Moving forward (prepared for travel) ..	35	35

*These speeds must not be exceeded, and on curves where authorized speed is more than 15 MPH speed must be reduced to 5 MPH less than shown in timetable and on speed signs.

**Scale Test Car NBS-1 to be handled on trains not more than 20 cars ahead of caboose and speed of train handling NBS-1 not to exceed 60 MPH.

①When moving in train with boom in place, operator must be on board.

Unless specifically authorized, all relief outfit cranes and the following locomotive cranes and pile drivers: SPMW 4027, 4028, 4029, 4088, 5479, 5595, 5852, 5870, 5874, 5899, 6601, 6602, 6603, 6604, SSW 96404 and SSW 96405 must not operate over lines having maximum load limits of less than 263,000 lbs. and must observe all restrictions applying to cars weighing over 210,000 lbs.

18. MAXIMUM SPEED PERMITTED WITH CERTAIN EQUIPMENT	MPH MAIN TRACKS OTHER THAN BRANCHES	MPH MAIN TRACKS ON BRANCHES
	Double or multiple loads.....	
Scale test cars.....	40**	30
Except: SPMW 2024, 2025, WO-3.....	65	49
Relief outfits with steam derrick, except..	45*	25*
Relief outfits 7070 and 7110 must not exceed 35 MPH* and relief outfit 7050 must not exceed 30 MPH* on main tracks other than branches. Relief outfits 7070 and 7110 must not be operated on any branch.		
Relief Outfit SPMW 7150.....	35*	25*
Rotary snow plows:		
Electrified.....	35	15
Locomotive Crane/Pile Drivers		
SPMW 6603 & 6604:		
With boom in place, either end forward①.....	25*	15*
With boom disconnected, heavy end forward.....	45	25
boom end forward.....	20*	15*
With boom disconnected and remov-		

19. OTHER MAXIMUM SPEEDS

	MPH PASSENGER TRAINS	MPH FREIGHT TRAINS
Trains of deadhead Passenger equipment with caboose.....	65	
Passenger trains, with caboose.....	65	
Engine and flanger only, except.....		40
On curves.....		35
Logs loaded on flat or logging cars, except.....		35
On curves.....		25
Through truss bridges, tunnels and passing stations.....		15
Trains handling empty bulkhead flat cars equipped with roller bearings, except series SP 590000-590111; SP 591100-591124; SSW 88050-88099.....		55
Trains handling pipe loaded on 89 ft. flat cars ..		55
PC 598500 to 598999 (Gondolas).....		55

When moving against current of traffic, or when movement is not protected by block signals, speed of passenger trains and light engines must not exceed 59 MPH, and speed of freight trains must not exceed 49 MPH, nor may speed exceed that applying to normal operation.

NOTE: Light engines, or engine with caboose only, are authorized to operate at Column 1 speeds not exceeding 55 MPH, except on descending grade without dynamic brake in operation must not exceed Column 2 speeds.

20. REPEATER AIR CARS (RAC) SP 260 Thru 266

The repeater air car (RAC) is utilized to increase efficiency of train air brakes on long trains and during cold weather. The purpose of repeater relay equipment is to accept pneumatic signals from the brake pipe of forward portion of a train, and by relay action, produce a corresponding response in the brake pipe of the rear section of the train.

The repeater relay car has the ability to produce faster train charging time, reduce or eliminate brake pipe pressure gradient, more uniform braking forces, and faster brake application and release times.

A. Procedure for adding Repeater Air Car to a train to use Repeater Car Air Equipment.

1. Place as near to center of train as makeup will permit.
2. The RAC car is operational in either direction. The front brake pipe must be coupled to the portion of the train to which the road engine is attached. The rear brake pipe must be coupled to the other end of the train.
The angle cock on the unused brake pipe on each end of the car must be closed.

3. Where repeater air car is positioned in train and front and rear brake pipes have been properly connected and opened, then close the brake pipe bypass cock No. 1 and open the two repeater relay cutout cocks Nos. 2 and 3, all located inside of car.

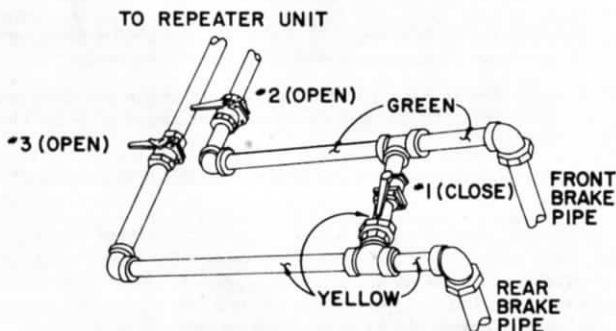

Note: If for any reason it becomes necessary to transfer control of air brakes to the helper engine located in the portion of the train behind the RAC car with the RAC air equipment in operation, the brake pipe hose connections must be changed. The forward brake pipe must be coupled to the portion of the train having the brake valve which is controlling the train. The rear brake pipe must be coupled to the other end of the train.

4. The repeater relay valve No. 5 is a variable valve and is employed to reestablish a satisfactory brake pipe pressure on the rear portion of train. A regulator and gage to indicate pounds of differential is provided. Trainline pressure on rear portion of train must not be increased above 90 PSI at RAC car. Preferred adjustment is to have the rear brake pipe 1.5 to 2 lbs. above the front brake pipe.

B. Procedure for cutting the RAC car out of train.

1. Close the repeater relay cutout cocks Nos. 2 and 3.
2. Open the brake pipe bypass cock No. 1—All located inside the car.
3. The car diesel engine and compressor are to remain running except during layover time.

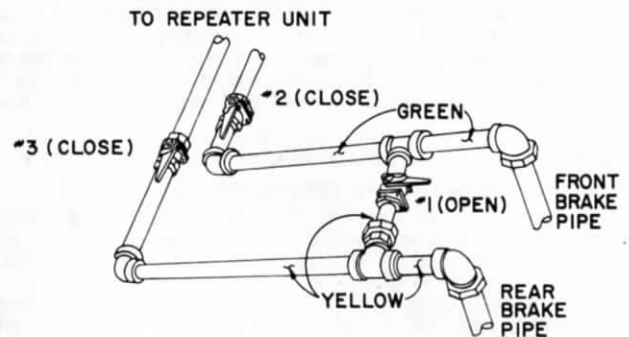
**C. Procedure for adding Repeater Air Car to a train when Repeater Car Air equipment is not to be used.**

1. Close the repeater relay cutout cocks Nos. 2 and 3.
2. Open the brake pipe bypass cock No. 1—All located inside the car.
3. Forward brake pipe must be coupled to portion of the train to which the road engine is attached.
Rear brake pipe must be coupled to the other end of the train. The angle cock on the unused brake pipe on each end of the car must be closed.

D. Train operation of Repeater Air Cars.

1. With the repeater air car in operation, proceed with terminal air test as prescribed in the air brake rules and regulations.
2. All rules outlined in the air brake rules and regulations governing train handling shall be adhered to while repeater air car is part of any train.
3. If required, the repeater air car may be cut out by closing the repeater relay cutout cocks Nos. 2 and 3 and opening the brake pipe bypass cock No. 1—All located inside car. This provides for normal train operation without the repeater relay equipment operating.
4. If yard air is used to charge the train, it must be cut in ahead of the repeater air car.
5. The RAC car must not be kicked, dropped, or humped and must be handled next to switch engine when being cut into or out of train and when being moved to caboose track.
6. During a pickup or setout, or at any time the engine is separated from the train and the air car is in operation in the train, it is absolutely essential that the trainline angle cock be left open on the train.

E. Loss of Main Reservoir Air on RAC car.

1. The depletion of main reservoir air to below 100 lbs. will initiate a service brake pipe reduction in the forward and rear portions of the train. The rotating red light on top of car will operate.
2. In addition to the red rotating light, a radio signal will be initiated and will transmit a series of short beeps for a period of approximately ten seconds and then cease. It will reset itself automatically upon an increase of main reservoir pressure above 110 pounds.
3. If in power, throttle must be reduced to idle and automatic brake valve placed in full service zone until train stops.
4. If in dynamic braking, automatic brake valve must be placed in full service zone and dynamic braking lever handled as prescribed by rules.
5. Train must be immediately secured before determining reason for main reservoir air depletion.

F. Setting RAC car out of train

1. If it becomes necessary to set RAC car out of train, shut down compressor engine in car and secure car per rules.

Instructions for starting and shutting down compressor engine posted inside of car.

RULE P. LOCATION OF OVERHEAD AND SIDE STRUCTURES NOT STANDARD CLEARANCE ON MAIN TRACK AND SIDINGS

MP	Location	Description
539.54	Tunnel No. 2	Overhead & side
542.45	Humboldt River bridge No. 24	Overhead & side
566.55	Ryndon Tunnel No. 3	Overhead & side
567.19	Ryndon Humboldt River bridge No. 25	Overhead & side
569.85	Ryndon Humboldt River bridge No. 27	Overhead & side
570.36	Ryndon Humboldt River bridge No. 28	Overhead & side
769.5	Little Mountain Great Salt Lake Chemical track scales	Overhead & side
778.51	Weber River bridge No. 2	Side
	Salt Lake Trestle (between Bridge and Tresend)	Side

RULE 10-J. Speed sign to right of track with one track intervening:

Westward	Reading	Eastward	Reading
MP 607.10	70-60	MP 606.63	40

Speed signs to left of track in direction of movement:

Westward	Reading	Eastward	Reading
MP 754.50	No. 2 Track 20 Thru turnout	MP 616.25	50
MP 641.51		70-60	

Speed signs duplicated to left of track:

Westward	Reading	Eastward	Reading
MP 754.50	60	MP 616.84	60
MP 739.70	70-60	MP 737.70	60
		MP 737.20	20

RULE 82-A. Eastward SP regular trains authorized on WP are also authorized to assume corresponding schedule or section of schedule at Alazon without obtaining SP clearance.

WP regular trains authorized on WP are also authorized to assume corresponding schedule or section of schedule at Alazon without obtaining SP clearance.

WP trains originating at WP Elko must obtain SP clearance "OK'd" by SP Chief Train Dispatcher.

RULE 83-A. Ogden: All trains except light engines and passenger trains will register at "RO" train-order office 28th Street. Incoming engineers of light engines will register their arrival at the Engine Crew Dispatcher's Office.

Conductor of passenger trains arriving will furnish register information via SP telephone Ext. 294 or 354 to "RO" train-order operator.

Engineers of passenger trains arriving will furnish register information to Engine Crew Dispatcher's Office via SP telephone Ext. 292 or 485.

RULE 83-B. Carlin: Trains No. 5 and No. 6 will register by ticket. Train orders and clearances will be delivered by messenger to Train No. 6.

RULE 93. Yard limits are established at the following locations:

West MP		East MP
533.40	Carlin	536.46
554.02	Elko	557.92
660.23	Montello	663.72
780.21	Ogden	

RULE D-97 applies:

Between Alazon and Moor.
Between Valley Pass and Lucin and between Bridge and Ogden.
Between Alazon and Carlin.

RULE 103. Elko and Wells: Trains stopping to perform switching must leave train clear of all street crossings.

RULE 104. Eastward trains after having been instructed to operate directly to DRGW will enter connection through spring switch located just east of Signal P-7802 and a member of crew will hand throw switch and return switch to normal position after movement is completed.

RULE 105. Montello: No. 1 track is for use of eastward trains only and when necessary for westward trains to use No. 1 track permission must be obtained from train dispatcher.

Little Mountain: When necessary to use siding permission must be obtained from train dispatcher.

RULE 204. Westward WP trains on the Ogden or Sparks Subdivisions, with the same conductor and engineer operating through Carlin, may be issued train orders on one subdivision that affect their movement on the other or both subdivisions.

When train orders are issued at Carlin which affect movement of SP trains east of Alazon, train-order operator must deliver such train orders with a clearance OK'd by SP Chief Train Dispatcher.

RULE 221. Ogden: Conductor of freight trains originating will pick up clearances and train orders from "RO" train-order office at on-duty time if their train has been cleared. Otherwise, clearances will be delivered by tube to 21st Street.

Conductors of passenger trains originating will obtain clearances issued at "RO" train-order office which will be delivered by tube to change room at passenger depot.

Elko: Is a train-order office only for trains originating.

RULE D-251. Will apply as follows:

On both main tracks between Alazon and Moor, Valley Pass and Lucin, and Bridge and Ogden.

Between Alazon and Carlin.

RULE 292. Carlin: Westward freight trains or engines must not pass Signal 5359 unless flashing white light is displayed or proceed signal is received from yardman or orally authorized to proceed.

When Signal 5359 displays stop indication and flashing white light is displayed, such trains and engines may proceed without stopping on main track or diverging route at restricted speed.

RULE 306. The following home signals equipped with triangular plate bearing the letter "P" have included in their control limits some special protective device. Absolute signals are listed as P-A or P-SA:

Eastward Signal	Protection	Westward Signal
	Rock slide fence over east portal Tunnel 2	P-5401
	Rock slide fence MP 541.08	P-5427
	Rock slide fence, east portal Tunnel 3	P-5673
	High water detector, Culvert MP 589.33	P-5915
	High water detector, Culvert MP 591.15	
	Spring switch EE crossover, Moor	P-SA
	Spring switch EE eastward siding, Moor	P-A

SPECIAL INSTRUCTIONS—OGDEN SUBDIVISION

Eastward Signal	Protection	Westward Signal
P-A	Spring switch west end westward siding, Valley Pass	
	High water detector, Culvert MP 672.14 westward track	P-6733
	High water detector, Culvert MP 677.32 westward track	P-6775
	High water detector, Culvert MP 679.33 westward track	P-SA
P-6780	High water detector, Culvert MP 679.33 eastward track	{ P-SA P-A
	Spring switch east end eastward siding, Lucin	P-A
P-7428	Fill slide detector (No. 1 track) MP 743.25	P-A
*P-7476	Fill slide detector, east of Midlake, MP 747.66	P-7491
	Spring switch EE crossover—MP 780.15	P-7801
P-7802	Spring switch SP-DRGW connection	
	SP-DRGW connection	P-7803
	Spring switch EE crossover—MP 780.15	P-7805

*Limits of fill slide detector will be indicated by rotating red light when fill detector is actuated. Revolving red lights located as follows:

Eastward	MP 747.6
Westward	MP 748.1

When signals with triangular plate bearing letter "P" display stop indication in connection with fill slide detector (No. 1 Track) MP 743.25 and fill slide detector, east of Midlake, MP 747.66, inspection of track and structure may be made from engine.

AUTOMATIC BLOCK SIGNAL SYSTEM

RULE 505. Westward trains moving from SP-DRGW connection to main track must stop at Signal P-7801 and member of crew must push button bearing number P-7801 located on signal case. When Signal P-7801 indicates proceed, train may proceed.

Westward trains finding Signal P-7803 in stop position after stopping, member of crew must push button bearing number P-7803 located on signal case. When Signal P-7803 indicates proceed, train may proceed.

After member of crew has actuated push button, if signal does not clear, train may then proceed only after complying with Rules 81-A and 507, and in addition careful examination must be made of all facing point switches.

East Carlin: Detour extends from east ice house lead on SP to East Carlin on WP.

Eastward SP freight trains and other trains when so directed, also engines moving between WP and SP yards will use East Carlin and/or West Carlin detours.

West Elko: Detour extends from WP yard to West Elko on SP main track.

Junction switch is a spring switch and normal position is for SP main track.

Westward trains leaving WP yard via detour must enter approach circuit to indicate that such trains are ready to depart, and must not foul SP main track until letter "M" is displayed, or authority received from SP train dispatcher, either directly or through SP operator Carlin or WP operator at Elko.

When Signal 5545 on SP main track displays stop indication, westward trains on SP main track after stopping and obtaining train dispatcher's permission, either directly or through operator Carlin or WP operator at Elko, may proceed under the provisions of Rule 507, provided it can be seen that there is no train or engine closely approaching west end of detour to enter SP main track.

Elko: East detour extends from SP siding to WP freight yard.

Montello: When Signal 6621 displays stop indication, permission must be obtained from train dispatcher before applying Rule 507.

RULE 507. Elko: When westward Signal 5565 displays stop indication, westward Southern Pacific freight trains must stop clear of Fourteenth Street crossing, and not proceed until signal displays proceed indication or it can be ascertained the block is not occupied by a preceding train or engine.

SPRING SWITCHES

RULE 538. Spring switches equipped with facing point locks are located as follows:

Location	Normal Position
Moor	East end crossover Main track
Moor	East end eastward siding Main track
Valley Pass	West end westward siding Main track
Lucin	East end eastward siding Main track

Spring switches not equipped with facing point locks are located as follows:

Location	Normal Position
*West Elko	West end WP detour Main track
*Alazon	West switch of crossover between SP and WP main tracks SP main track
*Wells	East switch eastward siding Main track
Ogden	Junction switch SP—DRGW connection Main track
*Ogden	West switch crossover MP 780.15 Main track
*Ogden	East switch crossover MP 780.15 Crossover

*Equipped with switch-point indicator.

INTERLOCKING

RULE 606. Ogden: Limits extend on eastward main track from signal at MP 780.65 to MP 780.70 (310 feet).

DRGW Crossings at MP 781.40.

LETTER-TYPE INDICATORS

RULE 705. Indicators located as follows:

Illum. Letter	On Signal	Approaching	Authorizes and requires movement as follows:
M	5543	WP connection	West Elko... Enter main track and proceed as prescribed by Rule D-251.
M	5565	Elko	Indicator applies to WP freight trains only. WP freight trains proceed on main track.
If letter "M" is not displayed, WP freight trains enter SP siding and proceed through crossover to WP freight yard.			
Display of letter "M" at West Elko, does not relieve conductors or engineers of compliance with Rule 81-A.			

CENTRALIZED TRAFFIC CONTROL

RULE 760. Limits extend from absolute signal MP 713.60 on WP main track and absolute signal MP 603.50 on SP main track and absolute signal MP 713.90 on WP main track and absolute signals MP 603.80 on SP eastward and westward main tracks. From end of double track at Moor to end of double track at Valley Pass and from west end eastward siding at Lucin to end of double track at Bridge.

Alazon: West switch of crossover between SP and WP main tracks is a spring switch and normal position is for SP main track.

When absolute signals display stop indication member of crew must contact train dispatcher for instructions. If signal can not be cleared train dispatcher may authorize member of crew to operate push buttons in box mounted on signal house north side SP track. Instructions are posted in box.

If absolute signal can not be cleared by operation of push buttons, movement may be made as prescribed by Rule 776 and in addition eastward movement to WP may only be made as prescribed by WP Rule 509(a).

Lucin: Trains moving against current of traffic finding absolute signal at west end westward siding displaying stop indication must obtain train dispatcher's permission to enter block and must ascertain that spring switch is properly lined.

Reverse movement after trailing through spring switch east end eastward siding Lucin must not be made until train dispatcher's permission is obtained and it is known that switch points have moved to proper position.

Bridge: Absolute signal located south of No. 2 Track, MP 752.4, governs eastward trains only.
Absolute signal located north of No. 2 Track (off trestle), MP 752.4, governs eastward trains on No. 2 Track only.
Absolute dwarf signal installed north of No. 2 Track, MP 752.5, governs westward movements as follows:

Top Unit To Fill on No. 1 Track
Bottom Unit To Trestle on No. 2 Track.

GENERAL REGULATIONS

RULE 812. Be governed by current timetable, bulletins and rules of WP, on WP track between Carlin and Alazon.

RULE 816. Members of crew making temporary repairs to hot bearings will be held personally responsible for control of burning waste to preclude possibility of starting fire on Salt Lake trestle.

RULE 825. Carlin Yard: Not less than three hand brakes must be applied on both east and west ends of unattended freight trains or cars.

Refer to Rule 825, All Subdivisions.

RULE 827. DRAGGING AND/OR DERAILED EQUIPMENT DETECTORS AND INDICATORS INSTALLED AT THE FOLLOWING LOCATIONS:

MP	LOCATION	PROTECTS DIRECTION(S)	ON TRACK
558.9	East of Elko	Both	Main Track
641.8	On Hot Box Detector Equipment House	Both	Eastward
676.4	Tecoma-Lucin Hot Box House	Both	Eastward
731.8	On Hot Box Detector Equipment House	Both	Main Track
757.9	On Hot Box Detector Equipment House	Both	Westward
776.0	On Signal 7760	Both	Eastward

HOT BOX DETECTORS

Illum. Letter	On Signal	Approaching	Location of Readout
H	5787	Halleck	MP 576.4 Halleck
W	5829	Halleck	
H	5961	Deeth	Signal 5937
W	5999	Deeth	
H	6187	Moor	MP 616.2 Moor
W	6206	Holborn	
H	6224	Holborn	MP 625.4 Holborn
W	6225	Moor	
W	6626	Tecoma	
H	6658	Tecoma	MP 669.3 Tecoma
H		Westward "A" Signal E.E. Lemay	Lemay Westward "A" Signal W.E. Lemay
W	7044	Groome	
W	7063	Lemay	
H	7082	Groome	Eastward Absolute Signal E.E. Groome
H		Westward "A" Signal E.E. Strong-knob	Strongknob Westward "A" Signal W.E. Strongknob
W	7314	Lakeside	
W	7327	Strongknob	
H	MP 733.4	Lakeside	Eastward Absolute Signal E.E. Lakeside
W	7628	Little Mountain*	MP 767.85 East End
H	7652	Little Mountain	Little Mountain

When letter "W" is illuminated, train must stop. Member of train crew must contact train dispatcher before proceeding and be governed by his instructions.

SCANNER SITES

MP	Type	Direction(s)	Location
547.1	D	West	Moleen*
581.0	A	West	Halleck-Deeth
599.0	A	West	Deeth
620.6	A	Both	Moor-Holborn
641.9	C	East	Valley Pass-Cobre
644.2	C	West	Cobre
664.0	A	East	Montello-Tecoma
665.8	C	West	Tecoma
676.4	C	Both	Tecoma-Lucin
683.8	C	Both	Lucin-Pigeon
706.0	A	Both	Lemay-Groome
731.8	A	Both	Strongknob-Lakeside
757.9	C	West	Bridge-Promontory Pt.
763.6	A	East	Promontory Pt.-Little Mtn.

*Readout in Carlin yard office.

Refer to Rule 827, All Subdivisions.

RULE 872. Carlin and Ogden: Enginemen taking charge of road engines will consider engines as having been amply supplied with water, fuel, sand and other supplies.

SPECIAL INSTRUCTIONS—OGDEN SUBDIVISION

AIR BRAKE RULES

FREIGHT TRAINS

RULE 2, A. Taking Charge of Engines.

Will apply at:

Carlin and Ogden.

RULE 17. Retaining valves must be used on descending grades as follows:

Moor to Wells, Valley Pass to Montello.

WITHOUT DYNAMIC BRAKE IN OPERATION:

One retaining valve for each 80 tons in train. If gross tonnage exceeds 80 tons per operative brake, retaining valves must be used on all cars and speed must not exceed 15 MPH.

WITH DYNAMIC BRAKE IN OPERATION:

Permissible Tons Per Unit Without Retaining Valves

	Basic Dynamic Brake		Extended Range Dynamic Brake		
	4 Axle	6 Axle	4 Axle	6 Axle	8 Axle
With dynamic brake in operation but without pressure maintaining system of braking.....	525	775	650	950	1275
With dynamic brake in operation and with pressure maintaining system of braking.....	1800	2700	2300	3500	4600

If permissible tonnage is exceeded, one retaining valve must be used for each 150 tons in excess thereof.

Retaining valves may be turned up when stops are made at any of the following stations:

- Westward . . . Holborn or Moor
- Eastward . . . Moor, Holborn, Pequop, Valley Pass, Cobre.

When retaining valves are used Valley Pass to Montello, stop for heat radiation need not be made if there is no indication of wheels overheating and in the judgment of engineer and conductor it is safe to proceed.

Refer to Air Brake Rule 17, All Subdivisions.

RULE 24. Will apply at Carlin to SP trains only.

RULE 24-G. Will apply at Elko.

RULE 25. Will apply to eastward trains at Valley Pass and to westward trains at Moor when retaining valves are being used, except when cars are to be set-out or picked up at Cobre. Eastward trains may pass Valley Pass without stopping for air brake test, provided test is made at Cobre.

To avoid additional stops at stations indicated above, trains may make inspection, air brake test and turn up retaining valves when stops are made at the following stations:

- Westward . . . Holborn or Moor
- Eastward . . . Moor, Holborn, Pequop or Valley Pass.

RULES 25-A and 26. Flashing light temperature indicators are installed at Signals 6186 and 6381, between Moor and Valley Pass. When flashing on approach of train, will indicate that the temperature is below 32 degrees.

When flashing, apply Rule 25-A, if unable to obtain a proper air test while running, train must be stopped and air brake hoses blown out as prescribed by Rule 26.

RULE 25-B. Will apply to westward freight trains when engine passes station one mile sign approaching Valley Pass, and to eastward freight trains when engine passes station one mile sign approaching Moor.

RULE 33. Restrictive grades are as follows:

EASTWARD	MP to MP		MPH
Cobre to East of Cobre	645.4	654.0	25
Tecoma to East of Tecoma	670.0	675.0	25
WESTWARD			
Moor to Wells	616.3	607.8	25

PASSENGER TRAINS

RULE 17. Use of retaining valves is not required when dynamic brake is in operation and/or pressure maintaining system of braking is being used on descending grades Moor to Wells and Valley Pass to Montello.

RULE 38. Will apply at Carlin.

MISCELLANEOUS

1. Engines listed must not operate on tracks shown below:

Class of Engine	Restricted Tracks
All engines	Lucin—Beyond engine restriction signs on South Spur.
All engines	Elko—Vogeler Whse. spur over track scale.
All engines	Carlin—Vogeler Whse. spur over track scale.
All engines	Little Mountain—Great Salt Lake Chemical spur over track scale.

2. LOAD LIMIT (car and contents):

Carlin-Ogden 315,000 pounds
 Refer to All Subdivisions, Page 20, Miscellaneous, Item 14.
 Unless authorized by Superintendent, heavier loads must not be handled.

3. SP and WP eastward trains will use WP track from Carlin to Alazon being governed by WP Rules, Timetable, Special Instructions and Timetable Bulletins.

SP and WP westward trains will use SP track from Alazon to Carlin being governed by SP Rules, Timetable, Special Instructions and Timetable Bulletins.

Current of traffic on SP track from Alazon to Carlin is westward and trains will operate under SP rules applicable to double track.

SPECIAL INSTRUCTIONS—OGDEN SUBDIVISION

SPEED RESTRICTIONS ON SIDINGS (AND TURNOUTS) AND CROSSOVERS

Location	With Caution Not Exceeding MPH	Location	With Caution Not Exceeding MPH
Elko	10	Lucin-North	10
Halleck	10	Lucin-South	10
Deeth	10	Pigeon	20
Wells	10	Jackson	20
Moor	20	Lemay	20
Moor (Crossover)	25	Groome	20
Holborn	10	Hogup	20
Pequop	10	Strongknob	20
Valley Pass	20	Lakeside (Crossover)	35
Valley Pass (Crossover)	45	Tresend (East Crossover)	20
MP 649.3 (Crossover)	20	Tresend (West Crossover)	35
Montello-North	10	Midlake (Track No. 1)	10
Montello-South	10	Bridge (East Crossover)	25
		Bridge (West Crossover)	25

RULES FOR MOVEMENT WITHIN THE OGDEN TERMINAL AREA

SP employes operating on tracks within the limits of the Ogden Terminal will be governed by SP rules and instructions insofar as they are not in conflict with the UP Rules or UP Special Rules contained herein.

RULE 7-C. All movements at 32nd St., Patterson Avenue, 29th St., and Cecil Jct. are controlled by switch-tenders who will use yellow flag by day, yellow light by night.

At Cecil Jct. all movements are controlled by switch-tender. Trains or engines must call for Signal as per Rule 14(j) and must receive proceed signal from switchtender before proceeding.

RULE 84. Amtrak trains will not depart passenger station without a signal from Amtrak representative.

RULE 98. Railroad crossings at Grade:

Grade Location	Railroad Crossings or Junction	How Governed
21st Street	DRGW main track crosses yard	Signal indication Rule 98.

RULE 505. Light type signal No. 7812 located 600 feet west of crossover Drill Track No. 1 to SP eastward main track governs eastward movements on eastward main track. Dwarf light type signal displaying stop indication only, located opposite signal 7812 and affects eastward movement on westward main track, and trains may proceed past this signal without stopping after receiving a Proceed signal from switch-tender at Cecil Junction.

Signal No. 7813 located at east end of crossover east of Cecil Junction, dwarf light type signal displaying stop indication only located 300 feet east of DRGW crossing, dwarf signal No. 78135 located on west end of crossover Drill Track No. 1, to eastward SP main track. Top unit governs westward movements from SP freight yard to SP westward main track. Bottom unit governs northward movement from SP yard to Union Pacific (OSL) main track.

If signals fail to clear after switchtender has made proper line up, trains may proceed without stopping on signal from switchtender.

Crossover installed between 21st St. and DRGW crossing between the old running rail and Drill Track No. 1 (old SP main track) must be lined for normal movement and locked when not in use.

RULE 605. Eastward light type interlocking signal located 10 feet west of dual control switch in vicinity of MP 780.67. Top unit governs movements on eastward main track. Bottom unit governs movements to freight lead.

Westward dwarf light type interlocking signals located at eastward interlocking limits 165 feet east of dual control switch between freight lead and eastward main track, and

between eastward main track and westward main track. These signals display stop indication only, and train or engine movements may be made beyond these signals only when authorized by the switchtender at Cecil Jct. under the provisions of Rule 663(b). Any movement beyond the opposing interlocking signal must only be made in accordance with Rule D-160.

RULE 663(c). Movements over DRGW main track at 21st St. are governed by signal indications. When a train or engine is stopped by signal governing movement over this crossing, and no conflicting movement is evident, a member of crew must be sent to the crossing to inspect derrails on DRGW. If derrails are in derailing position, train or engine may proceed on signal from employe at the crossing.

RULE 825. Train crews are responsible for applying sufficient hand brakes not less than five on descending end upon arrival Ogden, unless relieved by yardmaster.

SPEED RESTRICTIONS FOR OTHER THAN MAIN TRACKS

	With Caution Not Exceeding MPH
Through sidings, yard and other tracks and over railroad crossings	15
Except:	
Through crossovers and turnouts	10
North leg of wye 29th St. and Bridge Jct.	10
SP Diesel Pit and shop limits	8

Current Union Pacific bulletin orders will be posted on SP bulletin boards and the following UP Rules and Special Rules will apply:

UP Special RULE 93. Trains and engines using Drill 1, Drill 2 or Drill 3 between 29th St. and 32nd St. will move at restricted speed approaching these crossovers, stopping if necessary for conflicting moves. Trains and engines from the west moving into passenger station must use SP westward track to depot tracks 1, 2 and 4.

UP Special RULE 96. At Riverdale, between dual control switch locations at MP 989.6 and dual control switch located at MP 988.6, train and engine movements may be made in either direction on either track on signal indication or instructions from control operator 33rd St., Ogden. When eastward movement on westward main track is authorized by signal indication beyond MP 988.6, movement may be made to MP 986.9 without being proceeded by a flagman.

Westward automatic block signal at MP 986.9 is a stop signal (Rule 240-A). Rule 509 governs.

UP Special RULE 104. Yardmasters may authorize trains to line switches and move through Patterson Ave. area without receiving signal from switchtender.

GENERAL DESCRIPTION OF SIGNALS

Block signals and interlocking signals are of the color light type. Their aspects are shown by lights of the prescribed color as viewed from an approaching train and may be qualified by flashing of lights, or by number plate or letter plate.

Block and interlocking signals, as far as practicable, are located adjacent to or directly over the track which they govern.

Two signals may be bracketed and located on one supporting mast for displaying indications on two tracks, right hand signal governing right hand track and left hand signal the left hand track.

When a track intervenes between a signal and track governed, a stub post with a blue light at night, will be placed to the right of the signal.

Unless otherwise indicated, where two or more signals are located on the same mast, the upper signal will govern main route and the lower signal or signals will govern diverging route or routes.

At locations where one-unit or two-unit signal, located on signal bridge or mast, is accompanied by a dwarf signal at the same location governing movements on the same track in the same direction, such dwarf signal is to be regarded as the lower unit of a two-unit or three-unit signal.





Stop signals are designated by the absence of number plates and may also be marked by a plate bearing the letter "A." Stop-and-proceed signals are designated by number plates.

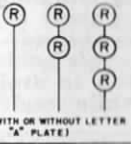
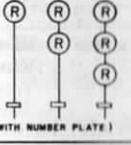

Block signal numbers indicate their location approximately in miles and tenths according to mile posts. Signals governing eastward trains have even numbers and signals governing westward trains have odd numbers.

Block and Interlocking Signal Indication

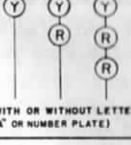
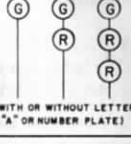
Aspects shown in Rules 240C through 240N may be displayed on signals with or without a number plate on the signal mast. Following symbols are used in diagrams of signal aspects:

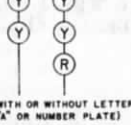
To indicate number plate ; To indicate flashing light 
 R signifies Red; Y signifies Yellow; G signifies Green

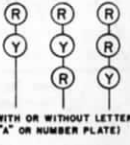
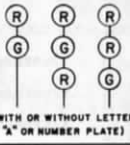
RULE	ASPECTS	NAME	INDICATION
240 A	 (WITH OR WITHOUT LETTER "A" PLATE)	Stop	Stop before any part of train or engine passes the signal.
240 B	 (WITH NUMBER PLATE)	Stop and proceed	Stop before any part of train or engine passes the signal then proceed at restricted speed through entire block.
240 C	 FLASHING RED LIGHT ON ANY SIGNAL	Flashing stop and proceed	Stop. Block occupied. Proceed at restricted speed.
240 D	 (WITH OR WITHOUT LETTER "A" OR NUMBER PLATE)	Approach	Proceed prepared to stop before any part of train or engine passes the next signal. Trains exceeding 30 MPH must immediately reduce to that speed.
240 E	 (WITH OR WITHOUT LETTER "A" OR NUMBER PLATE)	Clear	Proceed.
240 F	 FLASHING YELLOW LIGHT ON ANY SIGNAL	Advance approach	Proceed. Speed passing next signal must not exceed 40 MPH.
240 G	 (WITH OR WITHOUT LETTER "A" OR NUMBER PLATE)	Approach diverging	Approach next signal prepared to proceed on diverging route at prescribed speed.

RULE	ASPECTS	NAME	INDICATION
240 L	 (WITH OR WITHOUT LETTER "A" OR NUMBER PLATE)	Diverging approach	Proceed on diverging route prepared to stop at next signal. Prescribed speed through turn-out. Trains exceeding 30 MPH must immediately reduce to that speed.
240 M	 (WITH OR WITHOUT LETTER "A" OR NUMBER PLATE)	Diverging clear	Proceed on diverging route. Prescribed speed through turn-out.
240 N	 LUNAR LIGHT ON ANY SIGNAL	Restricting	Proceed on route indicated at restricted speed.

RULES GOVERNING OPPOSING AND FOLLOWING MOVEMENT OF TRAINS BY BLOCK SIGNALS

RULE 261. On portions of the railroad and on designated tracks so specified in the time-table, trains will be governed by block signals, whose indications will supersede the superiority of trains for both opposing and following movements on the same track.

UP Special RULE 261. Between absolute signals at Riverdale and Signal 9920, just east of Ogden Union Depot, Rule 261 is in effect on eastward track only. Cab signals will not indicate conditions ahead when moving west on eastward track. A westward train stopped by Signal 9909 or 9915, or an eastward train stopped by signal 9920, 9916 or 9910 must communicate with yardmaster at 33rd St., Ogden, and be governed by his instructions.

AUTOMATIC BLOCK SIGNAL SYSTEM RULES

RULE 505. Automatic block signals, cab signals, or both, govern the use of blocks but, unless otherwise provided, do not supersede the superiority of trains; nor dispense with the use or the observance of other signals whenever and wherever they may be required.

RULE 508. On any track signaled for traffic in both directions, block signals apply to trains in the direction of their movement on that track. On any track signaled for traffic in one direction, block signals apply to trains moving with the current of traffic on that track.

RULE 509. When a train or engine is stopped by an automatic block signal indicating Stop, and such indication does not change promptly to a more favorable indication, a member of the crew must immediately communicate with the train dispatcher and be governed by his instructions. When authorized by the train dispatcher to proceed, train or engine may, unless otherwise instructed, proceed at once at restricted speed to the next signal.

When communication with the train dispatcher is not available, or when so instructed by the train dispatcher, train or engine must be moved forward until leading wheels are 100 feet past the Stop signal, wait 10 minutes, and may then proceed at restricted speed to the next signal. If the track is seen to be clear of other trains or engines through to the next signal, and that signal displays Clear, Advance Approach or Approach, train or engine may proceed at restricted speed without waiting 10 minutes.

NOTE: Within yard limits of the Ogden Terminal area, movements on UP main track WITHIN BLOCK SYSTEM LIMITS must not exceed 35 MPH.

SPECIAL INSTRUCTIONS—SPARKS SUBDIVISION

RULE P. LOCATION OF OVERHEAD AND SIDE STRUCTURES NOT STANDARD CLEARANCE ON MAIN TRACK AND SIDINGS

MP	Location	Description
249.84	Vista	Truckee River bridge No. 5 Overhead & side
250.99	Vista	Truckee River bridge No. 6 Overhead & side
258.07	Patrick	Truckee River bridge No. 7 Overhead & side
299.87	Wadsworth	Truckee River bridge No. 1 Side
295.05		Government canal bridge Side
302.08	Fallon	Carson River bridge Side
302.50	Fallon	Government canal bridge Side
518.91	Barth	Humboldt River bridge No. 6 Side
519.68	Barth	Humboldt River bridge No. 8 Overhead & side
523.25		WPRR crossing Overhead
523.34		Humboldt River bridge No. 14 Overhead & side
525.15	Palisade	Humboldt River bridge No. 15 Side
525.20	Palisade	Tunnel No. 1 Overhead & side
525.42	Palisade	Humboldt River bridge No. 16 Side

RULE 7-C. Carlin: Eastward trains via Southern Pacific portion of paired track must not pass stop sign located at Mile Post 533.75 unless orally authorized or proceed signal is received.

Sparks: Switchmen must use green flag by day and green light by night or oral authorization in giving proceed signals for movement of trains or road engines.

RULE 10-J. Speed signs to right of track with one track intervening:

Westward	Reading
MP 343.80	70-55
MP 417.46	70-55

Speed signs to left of track with one track intervening:

Westward	Reading
MP 245.20	20

Speed signs located to left of track in direction of movement:

Westward	Reading	Eastward	Reading
MP 249.14	30	MP 244.16	30
MP 249.36	70-55	MP 247.14	70-55
MP 266.81	60-55	MP 248.61	60-55
MP 276.12	55	MP 252.70	60-55

RULE 14. Tule: WP westward trains must sound whistle signal o —, when passing sign reading "WP whistle" located at MP 425.10.

RULE 83-A. At the following stations, only the trains indicated will register:

Hazen.....Trains via Fallon Branch.

RULE 83-B. At open train-order offices, trains may register by ticket as follows:

Carlin.....Train Nos. 5 and 6 and Westward WP trains.

At Carlin, train orders and clearances will be delivered by messenger to Train No. 6.

RULE 93. Yard limits are established at the following locations:

West MP		East MP
237.49	Sparks	249.48
	Hazen (Mina Branch)	289.47
	Hazen (Fallon Branch)	289.23
356.00	Wendel	360.08
415.36	Mina	418.00
533.40	Carlin	536.46

Rule D-97 will apply:

Between Sparks and beginning of CTC Vista.
From Carlin to Weso and between Rose Creek and beginning CTC Perth.

RULE 99-C. Will apply on Mina Branch.

RULE 103. At the following stations there are crossings protected by gates which are not actuated when trains are stopping at station to receive or discharge traffic until train starts to move toward crossing, and speed of 10 MPH must not be exceeded until gates are down:

Station	Location	Direction	MP
Reno	Sierra St.	Westward	242.80
Reno	Virginia St.	Westward	243.00
Reno	Center St.	Westward	243.10

Locations at which train must stop to avoid unnecessary operation of crossing gates while receiving or discharging traffic:

Station	Location	Direction
Reno	60 ft. east of Center St.	Westward
Reno	230 ft. east of Virginia St.	Westward
Reno	60 ft. east of Virginia St.	Westward
Winnemucca	200 ft. west of Bridge St.	Eastward

Winnemucca: Crossing gate key control installed on Crossing Case 4175, Bridge Street. Eastward trains making stop west of Bridge Street on siding or house track must actuate key start before entering crossing.

Westward freight trains stopping to perform switching must leave train east of Bridge St. crossing or in siding, so as not to block crossing while engine is being attached or detached.

Eastward trains stopping on main track or siding at Winnemucca must stop 200 feet west of Bridge St. markers on south side of tracks.

Battle Mountain: Freight trains stopping to perform switching must leave train east of main road crossing to avoid blocking crossing when engine is coupled to train.

RULE 104. The normal position of rigid switches at end of double track and junctions is as follows:

Hazen (Mina Branch).....For controlled siding.
Hazen (Fallon Branch).....For Mina Branch.

RULE 204. WP train orders and clearances will be issued at SP train order office Wendel, and will apply to those who are to execute them on WP tracks between Flanigan and Carlin.

WP train orders and clearances for eastward SP trains will be issued at SP train order office, Sparks, and will apply to those who are to execute them on WP tracks between Weso and Carlin.

RULE 221. Lights will not be displayed in train-order signals on the Mina Branch.

RULE S-240. MOVEMENT OF TRAINS BY STAFF SYSTEM.

Applies at following location:

Territory	Register Location
Fallon Branch: Hazen-Fallon.....	Hazen

RULE D-251. Will apply as follows:

On both main tracks between Sparks and beginning of CTC Vista.

On both main tracks from end of CTC Perth to Rose Creek.

RULE 292. Carlin: Eastward SP trains or engines moving from west detour to Carlin Yard must not pass light unit mounted on mast at MP 534.10 on west detour until flashing white light is displayed unless proceed signal or oral authorization is received from switchman.

When flashing white light is displayed, trains and engines may proceed at restricted speed on route lined without stopping.

RULE 306. The following home signals equipped with triangular plate bearing the letter "P" have included in their control limits some special protective device. Absolute signals are listed as "P-A" or "P-SA"; interlocking signals are listed as "I" or "P-SA."

Eastward Signal	Protection	Westward Signal
P-2508 } P-A	Rock slide fence, MP 252.47	P-A
P-A	Rock slide fence, MP 254.52	P-2553
P-2554 } P-A	Rock slide fence, MP 256.59	P-A
P-A	Collision detector, roadway underpass, MP 275.36	P-A
P-A	Spring switch west end siding, Winnemucca ..	
	Spring switch east end siding, Winnemucca... P-A	
	Rock slide fence, MP 517.50-MP 518.10	P-5181
	Rock slide fence, MP 524.38	P-5255
	Rock slide fence, MP 527.00-MP 527.57	P-5277
	Rock slide fence, MP 530.54-MP 530.57	P-5315
	Rock slide fence, MP 530.65-MP 530.73	P-5315

When signals with triangular plate bearing letter "P" display stop indication in connection with rock slide fences at MP 517.50-MP 518.10; MP 524.38; MP 527.00-MP 527.57; MP 530.54-MP 530.57; MP 530.65-MP 530.73, inspection of track and structure may be made from engine.

AUTOMATIC BLOCK SIGNAL SYSTEM

RULE 505. Sparks: Eastward freight trains, except OAOGF, OAOGH, RVNPPY, RVRGY, RVNPP and RVOGP, must stop before passing Signal 2452 unless proceed signal is received from switchman or orally authorized. If proceed signal is received from switchman or orally authorized and signals displays stop indication, movement may be made as prescribed by Rule 507.

Signal 2468 governs movement of eastward trains from yard tracks. This signal is normally dark until switches are lined for crossover movement. If proceed signal is received from switchman or orally authorized and signal displays stop indication, train may proceed in accordance with Rule 81-A.

Westward freight trains, except UPSFF, UPMIA, UPWSA and UPSFT, must stop before passing Signal 2467 unless proceed signal is received from switchman or orally authorized. If proceed signal is received from switchman or orally authorized and signal displays stop indication, movement may be made as prescribed by Rule 507.

Carlin: Signal 5345 governs movement of westward trains from yard tracks and is normally dark until switches are lined for crossover movement. If proceed signal is received from switchman or orally authorized, and signal displays stop indication, train may proceed in accordance with Rule 81-A.

SPRING SWITCHES

RULE 538. Spring switches equipped with facing point locks are located as follows:

Station	Location	Normal Position
Winnemucca ..	East end siding	Main track
Winnemucca ..	West end siding	Main track
Weso	West switch, west crossover between SP and WP main tracks	WP main track
Weso	East switch, east crossover between WP and SP main tracks	WP main track

Spring switches equipped with switch point indicators are located as follows:

Sparks: East end of Tracks 21 and 22.
West end of Tracks 21 and 23.

INTERLOCKING

RULE 606. Weso: Limits extend between eastward signal on SP track, MP 420.75, and eastward signal on WP track, MP 535.80, to westward signal on SP track, MP 421.00, and westward signal on WP track, MP 536, and interlocking is under the control of WP train dispatcher at Sacramento.

Letter "A" on westward home signal at SP MP 421.00, Weso, applies for movements to WP and for movements onto SP CTC as well as through interlocking plant.

When signals display stop indication and cannot be cleared by WP train dispatcher WP Rule 663(b) will apply except westward movement to WP track may only be made as prescribed by WP Rule 509(a) and westward movement to SP track may not be commenced without additionally receiving SP train dispatcher's permission under Rule 776.

LETTER-TYPE INDICATORS

RULE 705. Indicators located as follows:

Illum.	On	Letter Signal	Approaching	Authorizes and requires movement as follows
S	P-A	Winnemucca eastward ..	Enter siding.	
S	P-A	Winnemucca westward ..	Enter siding.	

CENTRALIZED TRAFFIC CONTROL

RULE 760. Limits extend from MP 249.27 Vista to MP 340.26 Perth.

Limits extend from MP 406.50, Rose Creek, to MP 420.75, Weso.

Trains required to enter Winnemucca siding must not pass absolute signal in advance of spring switch until switch has been lined for siding.

Westward absolute signal located at crossover west end of Winnemucca stock track applies for movements to main track crossover only and does not restrict movements on house track.

GENERAL REGULATIONS

RULE 812. Be governed by current timetables, bulletins and rules of WP, on WP track between Carlin and Flanigan.

RULE 825. Sparks Yard: Not less than five hand brakes must be applied on east end of freight trains or cars. Hand brakes will not be applied if outgoing crew takes charge of train on arrival and if inbound crew is advised by yardmaster that engine is not to be detached.

SPECIAL INSTRUCTIONS—SPARKS SUBDIVISION

Carlin Yard: Not less than three hand brakes must be applied on both east and west ends of unattended freight trains or cars.

Refer to Rule 825, All Subdivisions.

RULE 827. DRAGGING AND/OR DERAILED EQUIPMENT DETECTORS LOCATED AT:

MP	LOCATION	PROTECTS DIRECTION(S)	ON TRACK
340.7	Perth	Both	Eastward
346.2	Lovelock-Colado	Both	Eastward
346.7	Colado	Both	Westward
355.8	Colado-Woolsey	Both	Westward
380.2	Humboldt-Imlay	Both	Eastward
387.2	Imlay-Mill City	Both	Westward
424.3	East of Tule	Both	Westward
465.0	Valmy-Mote Hot Box House	Both	Westward
479.65	East of Battle Mountain	Both	Westward
498.60	East of Mosel	Both	Westward
512.90	East of Beowawe	Both	Westward

HOT BOX DETECTORS

Illum. Letter	On Signal	Approaching	Location of Readout
H	2683	Thisbe	Westward Absolute Signal W.E. Thisbe
W	2684	Fernley	
W	2713	Thisbe	
H	2742	Fernley	Eastward Absolute Signal E.E. Fernley
H	3223	Ocala	Westward Absolute Signal W.E. Ocala
W	3224	Toy	
W	3255	Ocala	
H	3256	Toy	Eastward Absolute Signal E.E. Toy
H	4103	Rose Creek	MP 407.8 Rose Creek
W	4104	Winnemucca	
W	4127	Rose Creek	
H	4150	Winnemucca	MP 417.4 Winnemucca
H	4243	Tule	MP 422.8 Tule
W	4293	Tule	
H	4893	Argenta	MP 487.4 Argenta
W	4917	Argenta	
H	5091	Beowawe	MP 507.7 Beowawe
W	5133	Beowawe	

When letter "W" is illuminated, train must stop. Member of train crew must contact train dispatcher before proceeding and be governed by his instructions.

SCANNER SITES

MP	Type	Direction(s)	Location
251.6	D	West	Hafed
270.5	A	Both	Thisbe-Fernley
297.0	C	Both	Massie-Upsal
323.7	A	Both	Ocala-Toy
346.2	C	East	Lovelock-Colado
355.8	C	West	Colado-Oreana
380.2	C	East	Humboldt-Imlay
387.2	C	West	Imlay-Mill City
412.0	A	Both	Rose Creek-Winnemucca

MP	Type	Direction(s)	Location
427.3	A	West	Tule-Golconda
465.0	C	West	Valmy-Mote
491.0	A	West	Argenta-Mosel
512.5	A	West	Beowawe-Harney
639.1 (WPRR)	D	East	Approaching Carlin*

*This is an SP hot box detector and SP crews will be governed by applicable SP rules when approaching and passing this device. Readout for this detector in Carlin yard office.

Refer to Rule 827, All Subdivisions.

RULE 872. Sparks and Carlin: Enginemen taking charge of road engines will consider engines as having been amply supplied with water, fuel, sand and other supplies.

AIR BRAKE RULES

RULE 2, A. Taking Charge of Engines. Will apply at:

Sparks and Carlin.

FREIGHT TRAINS

RULE 17. Retaining valves must be used on descending grades as follows:

Reservation to Schurz:

WITHOUT DYNAMIC BRAKE IN OPERATION: One retaining valve for each 80 tons in train. If gross tonnage exceeds 80 tons per operative brake, retaining valves must be used on all cars and speed must not exceed 15 MPH.

WITH DYNAMIC BRAKE IN OPERATION:

Permissible Tons Per Unit Without Retaining Valves	Basic-Dynamic Brake		Extended Range Dynamic Brake		
	4 Axle	6 Axle	4 Axle	6 Axle	8 Axle
With dynamic brake in operation but without pressure maintaining system of braking:	650	950	800	1200	1600
With dynamic brake in operation and with pressure maintaining system of braking:	1600	2400	2000	3000	4000

If permissible tonnage is exceeded, one retaining valve must be used for each 150 tons in excess thereof. Refer to Air Brake Rule 17, All Subdivisions.

RULE 24. Will apply at Carlin (SP trains only).

RULE 24-G. Will apply at Sparks.

RULE 25. Will apply to eastward trains at Reservation when retaining valves are being used.

RULE 33. Reservation to Schurz: Maximum tonnage per operative brake—80 tons, except with dynamic brake and pressure maintaining system of braking in operation with not more than 20 cars for each six axles of dynamic brake; with speed not exceeding 25 MPH, and with all retaining valves on loaded cars in high pressure position—100 tons.

Should dynamic brake failure occur while handling in excess of 80 tons per operative brake, train may proceed at speed not exceeding 15 MPH if in the judgment of conductor and engineer it is safe to do so, and provided retaining valves are used as prescribed by Air Brake Rule 17.

SPECIAL INSTRUCTIONS—SPARKS SUBDIVISION

Restrictive grades are as follows:

MINA BRANCH

Eastward	MP to MP	Speed MPH
	337.5 340.0	25
	347.5 351.5	25
	394.2 396.6	25
Westward	394.2 393.0	25

PASSENGER TRAINS

RULE 38. Will apply at Sparks and Carlin.

MISCELLANEOUS

1. Engines listed must not operate on tracks shown below:

Class of Engine	Restricted Tracks
All engines.....	East Colado—Beyond curved portion of track at either end of Nevada Barth track. Carlin—Vogler spur over track scale.
All except AS 407, 409, 410, ES 406, 408, 409, 415, GS 407 class....	Reno—All industry tracks north of eastward main track between Park St. and WP interchange.

2. LOAD LIMIT (car and contents):

- *Sparks-Carlin..... 315,000 pounds
- *Hazen-Fallon..... 263,000 pounds
- Hazen-Wabuska..... 281,000 pounds
- *Wabuska-Mina..... 263,000 pounds

*Refer to All Subdivisions, Page 20, Miscellaneous, Item 14.

Unless authorized by Superintendent, heavier loads must not be handled.

3. SP and WP eastward trains will use WP track from Weso to Carlin.

SP and WP westward trains will use SP track from Carlin to Weso being governed by SP rules, Timetable, Special Instructions and Timetable Bulletins.

Current of traffic on SP track from Carlin to Weso is westward and trains will operate under SP rules applicable to double track.

SPEED RESTRICTIONS FOR TRAINS: Maximum speed of trains in territory shown below is subject to further restrictions applicable to engines in the train as shown in **SPEED RESTRICTIONS FOR ENGINES** appearing on page 19 and **MAXIMUM SPEED PERMITTED WITH CERTAIN EQUIPMENT** and **OTHER MAXIMUM SPEEDS** appearing on page 21 of Timetable for All Subdivisions. Speed must be further reduced as prescribed by speed signs, except as specifically authorized by Special Instructions herein, or by timetable bulletin.

EASTWARD			PSGR TRAINS	FRT	WESTWARD			PSGR TRAINS	FRT
MP	MP	Column:	1	2	MP	MP	Column:	1	2
SPARKS to WESO:					CARLIN to SPARKS:				
246.20 to 247.14...			30	30	534.80 to 533.90...			25	25
247.14 to 249.36...			70	55	533.90 to 528.00...			60	55
249.36 to 249.40					528.00 to 525.86...			45	45
(through turnout).....			50	50	525.86 to 517.90...			55	50
249.40 to 252.06...			70	55	517.90 to 500.91...			70	55
252.06 to 252.70...			40	40	500.91 to 500.31...			65	55
252.70 to 253.80...			60	55	500.31 to 476.00...			70	55
253.80 to 258.06...			70	55	*476.00 to 475.30...			45	45
258.06 to 258.08...			50	50	475.30 to 442.60				
258.08 to 262.34...			70	55	(428.62).....			70	55
262.34 to 264.81...			60	55	428.62 to 424.74...			60	55
264.81 to 270.85...			70	55	424.74 to 417.46...			70	55
270.85 to 273.76...			60	55	417.46 to 417.44...			45	45
273.76 to 274.12...			55	55	417.44 to 406.54...			70	55
274.12 to 340.16...			70	55	406.54 to 406.50				
340.16 to 340.23					(through turnout).....			50	50
(through turnout).....			50	50	406.50 to 344.80...			70	55
340.23 to 343.80...			70	55	344.80 to 343.80...			40	40
343.80 to 344.80...			40	40	343.80 to 340.23...			70	55
344.80 to 406.50...			70	55	340.23 to 340.16				
406.50 to 406.54					(through turnout).....			50	50
(through turnout).....			50	50	340.16 to 274.12...			70	55
406.54 to 417.44...			70	55	274.12 to 273.76...			55	55
417.44 to 417.46...			45	45	273.76 to 270.85...			60	55
417.46 to 420.87...			70	55	270.85 to 264.81...			70	55
420.87 to WP					264.81 to 262.34...			60	55
535.97 (through crossover to WP).....			25	25	262.34 to 258.08...			70	55
					258.08 to 258.06...			50	50
					258.06 to 253.80...			70	55
					253.80 to 252.70...			60	55
					252.70 to 252.06...			40	40
					252.06 to 249.40...			70	55
					249.40 to 249.36				
					(through turnout).....			50	50
					249.36 to 247.14...			70	55
					247.14 to 246.20...			30	30

***Battle Mountain:** When engine passes last crossing within limits of restriction in direction of movement, speed may be resumed to that shown on next speed sign.

Trains with AMTRAK EP 630A engines in consist, unless otherwise restricted to a lower speed, must not exceed 50 MPH from point where engine enters curve until engine and first car behind engine are again on tangent track between the following mile post locations:

Eastward	Westward
MP 253.2 and MP 253.6	MP 533.1 and MP 532.3
MP 262.3 and MP 264.8	MP 525.0 and MP 517.9
MP 266.7 and MP 267.1	MP 500.8 and MP 500.3
MP 270.8 and MP 271.7	MP 443.5 and MP 442.6
MP 273.7 and MP 274.1	MP 434.3 and MP 433.9
MP 388.1 and MP 388.4	MP 428.7 and MP 426.4
	MP 425.0 and MP 424.7
	MP 422.3 and MP 421.8
	MP 274.1 and MP 273.7
	MP 271.7 and MP 270.8
	MP 267.1 and MP 266.7
	MP 264.8 and MP 262.3
	MP 253.6 and MP 253.2

SPECIAL INSTRUCTIONS—SPARKS SUBDIVISION

Trains handling tank cars containing Flammable Compressed Gas must not exceed 55 miles per hour. Where maximum authorized speed is less than 55 MPH and more than 25 MPH, train must be operated at 5 MPH less than maximum authorized speed and must not exceed 30 MPH at the following locations:

Eastward, Sparks to Weso:

Lovelock MP 343.8 to MP 344.8
 Winnemucca MP 417.0 to MP 418.0

Westward, Carlin to Sparks:

Battle Mountain MP 475.9 to MP 475.0
 Winnemucca MP 418.0 to MP 417.0
 Lovelock MP 344.8 to MP 343.8

SPEED RESTRICTIONS FOR OTHER THAN MAIN TRACKS		With Caution Not Exceeding MPH
Through sidings, yard and other tracks, wyes, balloon tracks, crossovers and turnouts		10
Except:		
Barth: Over Nevada Barth Co. track scales		3

SPEED RESTRICTIONS ON SIDINGS (AND TURNOUTS)			
Location	With Caution Not Exceeding MPH	Location	With Caution Not Exceeding MPH
Hafed	10	Granite Point	10
Patrick	20	Lovelock-North	10
Clark	10	Lovelock-South	10
Thisbe	20	Rye Patch	10
Fernley	20	Imlay (Crossover)	10
Darwin	20	Winnemucca	20
Hazen	10	Iron Point	10
Massie	20	Mote	10
Upsal	20	Battle Mountain	10
Parran	20	Mosel	10
Ocala	20	Beowawe	10
Toy	20		

Maximum authorized speed for freight trains is 55 MPH.

EXCEPTIONS:

- (a) Freight trains may operate at Column 1 speeds not exceeding 65 MPH when authorized by train order, provided train has no restricted cars or empties except cabooses and does not exceed 80 tons per operative brake and/or 120 cars.
- (b) Western Pacific Train OMW with no restricted cars or empties except caboose and not more than 70 tons per operative brake or 70 cars, is permitted to operate at Column 1 speeds not exceeding 70 MPH on the Southern Pacific's portion of the paired track between Alazon and Weso.
- (c) Western Pacific freight trains may operate at Column 1 speeds not exceeding 65 MPH provided train has no restricted cars or empties except cabooses and does not exceed 80 tons per operative brake and/or 120 cars except trains required to operate at column 2 speeds on WP will not exceed column 2 speeds on Southern Pacific track.
- (d) Freight trains handling empties other than cabooses are restricted to 40 MPH between MP 308.00 and MP 309.00, between Upsal and Parran.
- (e) Train UPSFT with no restricted cars or empties, except caboose, when consisting of more than 50% multi-level equipment and not more than 70 tons per operative brake may be authorized by train order to operate at Column 1 speed not exceeding 70 MPH.

- (f) Train UPSFT with no restricted cars or empties, except caboose, consisting of not more than 50% multi-level equipment and not more than 80 tons per operative brake, may be authorized by train order to operate at Column 1 speed not exceeding 70 MPH.

SPEED RESTRICTIONS FOR TRAINS: Maximum speed of trains in territory shown below is subject to further restrictions applicable to engines in the train as shown in **SPEED RESTRICTIONS FOR ENGINES** appearing on page 19 and **MAXIMUM SPEED PERMITTED WITH CERTAIN EQUIPMENT** and **OTHER MAXIMUM SPEEDS** appearing on page 21 of Timetable for All Subdivisions. Speed must be further reduced as prescribed by speed signs, except as specifically authorized by Special Instructions herein, or by timetable bulletin.

BETWEEN		ALL TRAINS
MP	MP	
HAZEN AND MINA:		
288.35 and 289.47		20
289.47 and 301.06		40
301.06 and 301.56		35
301.56 and 302.95		40
302.95 and 303.36		35
303.36 and 317.13		40
317.13 and 317.23		30
317.23 and 318.06		40
318.06 and 318.15		25
318.15 and 319.21		40
319.21 and 319.57		35
319.57 and 324.68		40
324.68 and 325.10		35
325.10 and 328.00		40
328.00 and 349.67		20
349.67 and 349.76		15
349.76 and 357.50		20
357.50 and 361.50		35
361.50 and 369.83		20
369.83 and 371.08		25
371.08 and 383.00		20
383.00 and 415.36		25
415.36 and 417.00		20
HAZEN AND FALLON:		
288.35 and 303.90		10

Trains handling tank cars containing Flammable Compressed Gas where maximum authorized speed is less than 55 MPH and more than 25 MPH, train must be operated at 5 MPH less than maximum authorized speed.

SPEED RESTRICTIONS FOR OTHER THAN MAIN TRACKS		With Caution Not Exceeding MPH
Through sidings, yard and other tracks, wyes, crossovers and turnouts		10

SPECIAL INSTRUCTIONS—ROSEVILLE SUBDIVISION

FIXED SIGNALS

Roseville: Westward freight trains and engines from Roseville Subdivision must stop clear of Berry St. crossing, MP 107.20 unless oral authority is received from herder or flashing white light is displayed in indicator just west of Berry St.

RULE P. LOCATION OF OVERHEAD AND SIDE STRUCTURES NOT STANDARD CLEARANCE ON MAIN TRACK AND SIDINGS

MP	Location	Description
88.54	Sacramento	Sacramento River bridge Side and overhead
92.15	Elvas	American River bridge Side

ROSEVILLE-SPARKS—No. 2 TRACK

111.21	East of Rocklin	Antelope Creek Bridge Side
114.20	East of Rocklin	Tunnel No. 15 Side and overhead
114.70	East of Rocklin	Tunnel No. 16 Side and overhead
117.30	East of Rocklin	Tunnel No. 17 Side and overhead
120.50	East of Newcastle	Tunnel No. 18 Side and overhead
123.10	East of Newcastle	Tunnel No. 20 Side and overhead
124.60	East of Nevada St., Auburn	Tunnel No. 21 Side and overhead
131.20	East of Bowman	Tunnel No. 22 Side and overhead
132.70	East of Bowman	Tunnel No. 23 Side and overhead
132.90	East of Bowman	Tunnel No. 24 Side and overhead
133.10	East of Bowman	Tunnel No. 25 Side and overhead
133.30	East of Bowman	Tunnel No. 26 Side and overhead
133.80	East of Bowman	Tunnel No. 27 Side and overhead
134.80	East of Applegate	Tunnel No. 28 Side and overhead
135.90	East of Applegate	Tunnel No. 29 Side and overhead
138.70	East of Applegate	Tunnel No. 30 Side and overhead
139.20	East of Applegate	Tunnel No. 31 Side and overhead
139.40	East of Applegate	Tunnel No. 32 Side and overhead
164.34	East of Midas	Tunnel No. 1 Side and overhead
176.60	East of Emigrant Gap	Tunnel No. 35 Side and overhead
176.90	East of Emigrant Gap	Tunnel No. 36 Side and overhead
177.80	Crystal Lake	Tunnel No. 37 Side and overhead
177.87 to 198.91	Crystal Lake to Andover	Snow sheds and signals in Snowsheds Side and overhead
180.50	East of Cisco	Tunnel No. 38 Side and overhead
180.70	East of Cisco	Tunnel No. 39 Overhead
185.30	East of Cisco	Tunnel No. 40 Side and overhead
193.30	East of Norden	Tunnel No. 41 Side and overhead
200.10	East of Shed 47	Tunnel No. 42 Side and overhead
180.38	East of Cisco	Signal Bridge No. 1804 Overhead
182.38	East of Cisco	Signal Bridge No. 1824 Overhead
184.02	East of Cisco	Signal Bridge No. 1844 Overhead
188.03	East of Troy	Signal Bridge No. 1880 Overhead
189.88	East of Troy	Signal Bridge No. 1900 Overhead
191.75	Norden	Signal Bridge No. 1919 Overhead
201.28	East of Andover	Signal Bridge Overhead
209.12	East of Truckee	Signal Bridge No. 2096 Overhead
210.60	East of Truckee	Signal Bridge No. 2106 Side and overhead
212.63	East of Truckee	Signal Bridge No. 2124 Side and overhead
214.71	East of Truckee	Signal Bridge No. 2146 Side and overhead
218.05	East of Boca	Signal Bridge No. 2180 Side
220.03	East of Boca	Signal Bridge No. 2200 Side and overhead
221.88	East of Boca	Signal Bridge No. 2220 Side and overhead
230.12	East of Floriston	Signal Bridge No. 2300 Overhead
231.50	Verdi	Signal Bridge No. 2316 Side and overhead
237.02	Lawton	Signal Bridge No. 2370 Overhead
238.90	East of Lawton	Signal Bridge No. 2390 Side

SPARKS-ROSEVILLE—No. 1 TRACK

238.90	West of Reno	Signal Bridge No. 2389 Side
231.50	Verdi	Signal Bridge No. 2317 Side and overhead
230.12	West of Verdi	Signal Bridge No. 2301 Overhead
229.65	West of Verdi	3rd Truckee River Crossing Side
221.88	West of Floriston	Signal Bridge No. 2219 Overhead
220.65	West of Floriston	1st Truckee River Crossing Side
220.03	West of Floriston	Signal Bridge No. 2201 Side
218.26	West of Floriston	Highway Bridge Overhead
218.05	West of Floriston	Signal Bridge No. 2181 Side
214.71	West of Boca	Signal Bridge No. 2147 Side and overhead
212.63	West of Boca	Signal Bridge No. 2125 Side and overhead
212.25	West of Boca	Highway Bridge Overhead
210.60	West of Boca	Signal Bridge No. 2107 Overhead
209.12	West of Boca	Signal Bridge No. 2109 Overhead
207.55	West of Truckee	Signal Bridge No. 2075 Overhead
200.22	Andover	Tunnel No. 13 Side and overhead
198.91 to 177.87	Andover to Crystal Lake	Snowsheds and signals in snowsheds Side and overhead
195.70	West of Shed 47	Tunnel No. 12 Side and overhead
195.20	West of Shed 47	Tunnel No. 11 Side and overhead
195.10	West of Shed 47	Tunnel No. 10 Side and overhead
194.90	West of Shed 47	Tunnel No. 9 Side and overhead
194.30	West of Shed 47	Tunnel No. 8 Side and overhead
194.25	West of Shed 47	Stone Wall Side
194.10	West of Shed 47	Tunnel No. 7 Side and overhead
193.70	West of Shed 47	Tunnel No. 6 Side and overhead
191.75	West of Norden	Signal Bridge Overhead

MP	Location	Description
189.88	West of Norden	Signal Bridge No. 1901 Overhead
184.40	West of Troy	Signal Bridge No. 1841 Overhead
182.38	West of Troy	Signal Bridge No. 1823 Overhead
181.00	West of Troy	Tunnel No. 4 Side
180.70	West of Troy	Tunnel No. 3 Side and overhead
180.38	Cisco	Signal Bridge No. 1803 Overhead
164.34	West of Blue Canon	Tunnel No. 1 Side and overhead
132.90 to 122.00	West of New England Mills to West of Auburn	Rock Cuts Side
127.86	Bowman	Highway Bridge Overhead
120.50	Newcastle	Tunnel No. 18 Side and overhead
111.21	East of Rocklin	Under Structure Side and overhead

RULE 7-A. Yellow flags and unattended red flags, red lights and green flags must be respected when placed to the left of track between *MP 195.3 and MP 246.2.

*Mile post locations above are those shown for No. 2 Track.

RULE 7-C. Sacramento, Roseville and Sparks: Switchmen must use green flag by day and green light by night or oral authorization in giving proceed signals for movement of trains, **except at Roseville** proceed signal for movement to or from East Valley Subdivision a yellow flag by day and yellow light by night or oral authorization must be used.

Roseville: Eastward trains, except first class, must not leave unless proceed signal (green flag by day, green light by night) or oral authority received from switchman. Will not apply to eastward extra trains consisting exclusively of passenger equipment on continuous main track movement through Roseville.

Antelope: Westward trains and engines (except yard engines) using running track must not pass fouling point unless proceed signal received from switchman, green flag by day, green light by night, or oral authorization or signal received from trainman of the same crew.

RULE 10-J. Speed signs to right of track in current of traffic direction with one track intervening:

Westward	Reading	Eastward	Reading
MP 91.15	10	MP 106.88	35

Speed signs to left of track with one track intervening:

Westward	Reading	Eastward	Reading
*MP 245.20	20		

*Is located 1.10 miles instead of 2 miles from point of restriction.

Westward speed sign at MP 94.90 is 2.34 instead of 2 miles from point of restriction.

RULE 14(1). Westward trains will sound crossing whistle signal immediately after emerging from west portal of Tunnel Nos. 6 and 41, west of Eder.

RULE 81-A. Sacramento: Before entering main track at 7th or 15th Street, trains and engines except yard engines must receive proceed signal from switchman at location where entry is made or movement orally authorized by yardmaster or his representative.

Sacramento Northern trains preparing to enter SP tracks at 19th & B, or 22nd & B Sts., must stop clear of fouling point, or derail if any, and member of crew must contact SP yardmaster for permission to enter SP tracks. Before switch is lined it must be known by observation that there is no movement closely approaching track to be occupied. CCT trains preparing to enter SP tracks at 22nd St. must stop clear of fouling point and crew member contact SP yardmaster. Before switch is lined it must be known by observation that there is no movement closely approaching track to be occupied. When CCT trains clear SP tracks at 22nd St. member of crew must advise SP yardmaster.

RULES 82-A and 221. Train orders and clearances issued on the Roseville Subdivision will apply on the Stockton Subdivision and vice versa.

SPECIAL INSTRUCTIONS—ROSEVILLE SUBDIVISION

Crews on extra trains originating at Roseville and turning at Sacramento may leave without obtaining a clearance.

Sacramento Northern trains originating at Sacramento, 19th and B Sts., or Sacramento-Yolo Port District connection to Western Division must obtain clearance at Sacramento. Train-order office Sacramento is located in passenger station.

Trains to Martinez Subdivision at Sacramento originating at Roseville or Elvas and operating through with same conductor and engineer will be issued clearance and/or train orders at Roseville to apply on Martinez Subdivision and will not obtain clearance at Sacramento.

Trains to Roseville Subdivision at Sacramento and operating through with same conductor and engineer, EXCEPT TRAINS OF PASSENGER EQUIPMENT, may be issued clearance and/or train orders on Martinez Subdivision to apply on Roseville Subdivision and will not obtain clearance at Sacramento.

RULE 83-A. At the following stations, only the trains indicated will register:

Sacramento—Trains originating or terminating, except extra trains passing Sacramento to or from Western Division.

Sacramento Northern trains to Western Division will register at Sacramento train order office.

Roseville—All trains except first-class trains, extra trains consisting entirely of passenger equipment and not terminating at Roseville.

RULE 83-B. Trains No. 5 and No. 6 may register by ticket at Sacramento.

RULE 93. Yard limits are established at the following locations:

West MP	East MP
85.51	Sacramento 98.04
	Sacramento (Walnut Grove Branch) 93.09
98.04	Roseville (Eastward and No. 2 Track) 110.87
98.04	Roseville (No. 1 and Westward Track) 110.87
119.34	Newcastle (No. 2 Track) 120.82
118.74	Newcastle (No. 1 Track) 120.15
122.66	Auburn 125.60
140.03	Colfax 142.94
169.11	Emigrant Gap 172.12
207.28	Truckee 209.09
237.49	Sparks 249.48

7. Roseville Diesel Service Facilities:

Westward movement must not be made over power operated switches on inbound lead unless movement is orally authorized by yardmaster or his representative.

Tracks 3 to 5 inclusive are equipped with electro-pneumatic controlled switches and switch point indicators. Indicators do not indicate track occupancy, but will display green aspect when switch is in normal position and yellow aspect when switch is in reverse position. When indicator light is not lighted, careful examination of switch must be made before making movement over switch.

Service lead from subway to oil, sandhouse and diesel facilities has stop sign located at fouling point of inbound lead to receiving tracks. After stopping it will be permissible to proceed if route is clear.

Switch position indicator located at:

Roseville Switch in westward running track.

Indicator does not indicate track occupancy but when displaying red, yellow or green aspects following will govern:

Red aspect Inoperative.
 Yellow aspect Switch lined for yard receiving unit.
 Green aspect Switch lined for running track Antelope.

Stop signs with reflective background are located on eastward yard running Track No. 21 between Antelope and Roseville. Instructions governing movement past each sign as follows:

West of Dry Creek Subway.
 East end Track No. 21.

Stop must be made unless proceed signal received from switchman or orally authorized by yardmaster or his representative or when yard engine is accompanied by yard crew.

8. ROSEVILLE HUMP MOVEMENTS

Light signals which govern hump movements located as follows:

South Hump At crest to right of track.
 North Hump At crest to left of track.

Light signals which repeat the aspect of hump signals located as follows:

South Hump To left of south lead track, west of manual crossover.
 North Hump To left of north lead track, west of manual crossover.

When crossovers west of crest are lined normal, the south hump repeater will repeat the aspect of the south hump signal, and the north hump repeater will repeat the aspect of the north hump signal.

When crossover west of crest is lined for movement from south receiving tracks to north hump, the south hump repeater signal will repeat the aspect of the north hump signal.

When crossover of crest is lined for movement from north receiving tracks to south hump, the north hump repeater signal will repeat the south hump signal.

These light signals do not indicate track occupancy or position of switches, but when displaying red, flashing red, yellow or green aspect, following will govern:

Aspect	Indication
Red	Stop
Flashing Red	Back
Yellow	Proceed at normal hump speed
Green	Proceed

For eastward movement of cars from receiving yard to crest, hump and repeater signals must display yellow or green aspect and in addition engineer instructed to move either orally or by hand or lamp signals by yardmaster or his representative in charge of movement.

Movement of cars toward crest of hump must not be made past repeater signal displaying red aspect unless engineer is orally informed by yardmaster or his representative that protection has been provided to safeguard the movement. Yardmaster before authorizing such a movement must know that crossovers west of crest are properly lined for such a movement and that humping movements from opposite hump through diamond crossover east of crest are stopped.

Movement of cars toward crest of hump when repeater signal displays red aspect may be authorized by yardmaster or his representative as far as the lead carman's tower.

Light signals which govern trim movements from bowl are located as follows:

South Hump At crest to left of track.
 North Hump At crest to right of track.

Light signals which repeat the aspect of the trim signals are located as follows:

- South Hump No. 1 repeater to left of track near 22-49 Switch Tower A-B.
No. 2 repeater between leads at 36-42 and 43-46 switches.
- North Hump No. 1 repeater to right of track near switch 1-21.
No. 2 repeater to right of track near switch 1-7.

These light signals do not indicate track occupancy or position of switches but when displaying red or yellow aspect, following will govern:

Aspect	Indication
Red	Stop
Yellow	Proceed

For westward movement from bowl tracks to crest, trim and repeater signals must display a yellow aspect, and in addition engineer instructed to move either orally or by hand or lamp signals by switchman in charge of movement. Movement must not be made west of fouling point of bowl tracks when trim and repeater signals display red aspect unless engineer is orally informed by yardmaster or his representative that movement is protected. Yardmaster authorizing such movement must insure that any conflicting movements are stopped.

Switch point indicators are provided on all power operated switches at west end of bowl. Westward movement must not be made to foul lead or any track diverging from lead unless switch is seen to be lined for the movement.

Tracks 23, 24 and 25 equipped with electrically controlled switches and switch point indicators. Indicators do not indicate track occupancy, but will display green aspect when switch is in normal position and yellow aspect when switch is in reverse position. When indicator lamp is not lighted, switch points must be checked to determine proper position before making movement over switch.

Trains or engines, except yard engines, must not enter tracks 23, 24 or 25 unless a proceed signal is received, green flag by day, green light by night, or engineer is orally authorized. When proceed signal received, or orally authorized, train or engine may proceed into track lined for movement.

Eastward movements from tracks 23, 24 and 25 are governed by indicator light located adjacent to No. 23 track switch.

Eastward movements, except yard engines, must not be made from tracks 23, 24 or 25 unless switches are lined and flashing white light is displayed or movement is orally authorized.

Westward movements, except yard engines, must not be made from tracks 23, 24 or 25 unless proceed signal received, green flag by day, green light by night or orally authorized.

Flashing white light located west of electrically operated switch on Tracks 21-25. Eastward movements, except yard engines, must not be made from Track 21 unless switch is lined and flashing white light is displayed or movement is orally authorized.

RULE D-97. Applies between Sacramento and Sparks.

RULE 98. Railroad crossings at grade not interlocked:

Sacramento: Switching and industry tracks in vicinity of Front and R Streets—Ascertain that each crossing is clear before using.

SNRy at Front and R Streets—Stop within 200 feet of crossing.

Roseville: Lead from yard to East Valley Subdivision main track crosses No. 2 Track and No. 1 Track of Roseville Subdivision near station sign. Eastward freight trains from yard to East Valley Subdivision will be governed by Signal 1062, and westward freight trains from East Valley Subdivision to enter yard will be governed by bottom unit of Signal 1063 before fouling or moving over No. 2 Track and No. 1 Track.

RULE 99-C. Will apply on Walnut Grove Branch.

RULE 103. Trains and engines must stop and be preceded by flagman before crossing highways at:

Sacramento: Spur track No. 130 crossing 23rd Street.

Cantilever flashing light signals in service at Walnut Grove Branch and Capitol Avenue crossing at Sacramento: Light type indicators located adjacent to crossing govern movement of trains and engines over Capitol Avenue. Green aspect indicates crossing gates and flashers have been actuated and movement may be made with caution. Red or dark aspect indicates stop.

Antelope: Crossing gate key control installed at "U" Street to actuate gates when backup movements made from westward main track.

Eastward trains stopping at Roseville within 400 feet of Yosemite Street crossing, when starting must not exceed 10 MPH until engine enters crossing.

Westward trains stopping at Truckee must stop with engine east of Signal 2083 to avoid unnecessary operation of automatic warning device at Bridge Street.

RULE 107. Station train indicator provided in approach to following station:

Westward:

Reno: On signal bridge with Signal 2437

When illuminated this indicator will convey the following information:

- TRAIN—Train at platform on opposite track.
- CLEAR—Indicator in service.

When neither TRAIN nor CLEAR is illuminated indicator is out of service and prompt report must be made to Chief Train Dispatcher.

RULE D-161. Antelope: Switchman's proceed signal, green and white flag by day, green and white light by night, will be an indication that protection has been provided for movement against current of traffic within yard limits on eastward main track.

RULE 221. Roseville: First class trains and trains consisting entirely of passenger equipment not terminating at Roseville are not required to obtain a clearance at Roseville.

Norden: Train-order signal located to the right of No. 2 track will apply to eastward trains on No. 2 track only.

Train-order signal installed to the left of No. 1 track will apply to eastward trains on No. 1 track only.

RULE D-251. Applies to the following tracks:

Both main tracks between Sacramento and Sparks.

Tracks between Roseville and Sparks numbered, and unless otherwise authorized, will be used as double track as follows:

- No. 1 Westward trains, via Auburn.
- No. 2 Eastward trains, via Auburn, Nevada Street.

RULE 306. The following home signals, equipped with triangular plate displaying the letter "P," have included in their control limits some special protective device. Interlocking signals are listed as "P-I."

Eastward Signal	Protection	Westward Signal
-----------------	------------	-----------------

- *Spring switch, Sacto-Yolo Port Dist. conn. P-I
- Spring switch, end double track, MP 103.14, Antelope P-I
- P-994 Collision barricade detector, MP 99.9 P-1009
- P-1228 Slide detector fence, Tunnel 20, MP 123.15 to 123.39 P-1251
- P-1242 Collision barricade detector, MP 124.7 P-1251
- Collision detector, highway underpass, MP 125.53
- Collision detector, highway underpass, MP 133.35 P-1347

SPECIAL INSTRUCTIONS—ROSEVILLE SUBDIVISION

Eastward Signal	Protection	Westward Signal
P-1374	Collision detector, highway underpass, MP 137.68	
P-1438	Slide detector fence, MP 144.46 to 144.66	
P-1508	Slide detector fence, MP 150.83	P-1515
P-1556	Slide detector fence, MP 156.32 to MP 156.38	P-1573
P-1582	Slide detector fence, MP 159.43 to MP 159.46	P-1611
P-I	Slide detector fence, MP 195.60 to MP 195.70, No. 1 Track	P-1963
P-2220	Slide detector fence, MP 222.16 to MP 222.34	
	Slide detector fences, MP 223.87 to MP 223.80	P-2239
	MP 222.88 to MP 222.77	
	MP 222.34 to MP 222.16	
P-2240	Slide detector fence, MP 224.50 to MP 223.80	P-2259

*If switch point indicator displays green aspect movement to Port District may proceed at restricted speed without hand throwing spring switch.

When signals with triangular plate bearing letter "P" display stop indication in connection with slide detector fences at MP 222.16 to MP 222.34; MP 223.87 to MP 223.80; MP 222.88 to MP 222.77; MP 222.34 to MP 222.16 and MP 224.50 to MP 223.80, inspection of track and structure may be made from engine.

AUTOMATIC BLOCK SIGNAL SYSTEM

Roseville: Westward freight trains and engines, except yard engines, or trains consisting entirely of passenger equipment, when making continuous movement on main track must not pass Signal 1065 unless proceed signal or oral authorization is received from switchman.

Movement of trains in both directions between eastward Signals 1060 and 1064 and westward Signals 1065 and 1067 on Roseville Subdivision and between eastward Signals 1062 and 1064 and westward Signal 1063 on East Valley Subdivision will be governed by signal indication which will supersede the superiority of trains, but movements must be made with caution, and only after block signal indicating proceed is displayed as prescribed below:

Signal 1064 on Track No. 1 governs eastward movement as follows:

- Top Unit To No. 1 Track
- Bottom Unit East Valley Line

Eastward movement on No. 2 Track is governed by Signal 1060.

Signal 1065 governs westward movement as follows:

- Top Unit To No. 1 Track
- Bottom Unit Thru crossover to No. 2 Track

Signal 1063 on East Valley Line governs movement as follows:

- Top Unit To Jct. switch to No. 1 Track
- Bottom Unit Across No. 1 and No. 2 Tracks to yard tracks

Signal 1062 on east drill track governs movement to East Valley Subdivision only.

Trains stopped by Signals 1060, 1062, 1063, 1064, 1065 or 1067 must not proceed until signal displays proceed indication, except may proceed after stopping if proceed signal or oral authorization is received from switchman, movement to be made with caution.

RULE 507. Roseville: Eastward trains leaving via drill track must not pass Signal 1072 displaying stop indication without contacting switchman orally.

Eastward freight trains leaving via No. 2 Track must not pass Signal 1074 displaying stop indication without contacting switchman orally.

RULE 509. Roseville: Westward freight trains and engines from Roseville Subdivision, after receiving proceed signal or oral authorization from switchman, may pass Signal 1065 displaying stop indication without stopping when movement is to be made into yard tracks.

SPRING SWITCHES

RULE 538. Spring switches equipped with facing point locks are located as follows:

Station	Location	Normal Position
Antelope	End of double track (MP 103.14)	Westward Track

Spring switches not equipped with facing point locks are located as follows:

Station	Location	Normal Position
*Sacramento	Sacto-Yolo Port Conn.	Sacto-Yolo Port Dist.
*Sacramento	Westward freight lead 2nd & H	Westward main track
*Roseville	East end east drill track	No. 2 Track
Roseville	East end Big Reno	East drill track
*Gold Run	East end eastward siding	No. 2 Track

*Equipped with switch-point indicator.

RULE 540. Roseville: Switch point indicator located to left of westward main track adjacent to movable point frog applies to westward trains or engines on westward main track. Westward trains and engines on westward main track to Antelope must not pass red aspect of switch point until switchman or yardmaster notified and position of switches are rechecked for proper position and authority received from switchman to proceed.

INTERLOCKING

RULE 606. Sacramento River Drawbridge: Westward Limits extend between MP 88.7 and MP 88.2; Eastward Limits extend between MP 87.9 and MP 88.6. Telephones are located adjacent to Signals 887, 889 and interlocking signals west end of drawbridge, east end of drawbridge and interlocking signal approaching main track from Port District. Sacramento River Drawbridge Ext. 339, Elvas Ext. 295.

Nineteenth Street, Sacramento: At crossing of R Street Track with WP.

Movements across WP main track are under control of WP train dispatcher who will control signals which govern movement but do not indicate occupancy of track. Upon receiving permission from WP Train Dispatcher, movements across WP main line must be made under provisions of Rule 663.

Telephones located in boxes at following locations:

West leg of WP wye track and R Street.

Steel relay shelter just south of crossing.

Elvas: Limits extend on Sacramento-Roseville line from interlocking signal 1800 feet west of tower to interlocking signal, 1370 feet east of tower.

Following switches are equipped with electric switch locks and must not be operated until permission has been obtained from operator whose instructions will govern movements not controlled by signal indicator:

Elvas American Can Co. Spur.

Antelope-Roseville: Limits as follows:

On main tracks between MP 102.50 Antelope and MP 106.64 Roseville.

Antelope: Eastward signal at MP 102.50 governs movement as follows:

- Top unit To eastward track.
- Middle unit To receiving track thru first switch.
- Bottom unit To receiving track thru second switch.

Roseville: Eastward signal at MP 106.16 governs movement as follows:

- Top unit To No. 2 Track.
- Bottom unit To No. 1 Track.

Telephones to operator are located at main track signals. Instructions for operation of dual control switch machines are posted in telephone booths.

Antelope: Switch to Los Angeles By-Product spur equipped with electric switch lock. Switch lock must not be operated until permission obtained from operator whose instructions will govern movement.

Norden: Limits extend on No. 1 Track and No. 2 Track from interlocking signals located on west end highway overpass Emigrant Gap, MP 171.87, to westward interlocking signals located on signal bridge MP 207.64, west end Truckee.

Run-around track and Turntable Lead 3—Trains or engines must obtain permission from operator before lining switch to siding.

Westward interlocking signal on No. 1 Track, 550 feet east of Norden station building connected with repeater signal on the left side of track for better visibility.

Call-on signals on certain interlocking signal masts are normally dark, but when displaying flashing yellow light is authority to pass interlocking signal displaying stop indication without obtaining permission from operator to couple to train or engine; movement to be made at restricted speed.

Bottom unit of interlocking signals for movements on siding may display lunar aspect. When lunar aspect is displayed, train or engine may proceed without stopping at restricted speed as per Rule 289.

Following switches equipped with electric switch locks:

1. Summit, Spur switch MP 193.4.
2. No. 1 Turntable Lead switch, No. 1 Track.

Lock box doors on electric switch locks must not be opened without permission of operator.

Truckee: Eastward Interlocking Signals governing movements to No. 1 track are equipped with **switch key actuator start boxes**. Permission must be obtained from Operator, Norden, before switch key is inserted in start box. Signals will not clear until switch key actuator is operated. **IN ADDITION, BEFORE MOVEMENT AGAINST CURRENT OF TRAFFIC IS MADE, PROTECTION MUST BE PROVIDED IN ACCORDANCE WITH PROVISIONS OF EITHER RULE D-160 OR RULE D-162.**

Signals will not clear until switch key actuator is operated by member of crew.

RULE 608. RULE 766-A. Applies on No. 1 Track and No. 2 Track from interlocking signals located on west end highway overpass, Emigrant Gap, MP 171.87, to westward interlocking signal located on signal bridge, MP 207.64, west end Truckee.

RULE 663. Roseville: Engines, after stopping, may pass westward interlocking signals at MP 106.64 to couple to train upon receipt of hand signal by herder, green flag by day, green light by night, or after being orally authorized.

LETTER-TYPE INDICATORS

RULE 705. Indicators located as follows:

Sacramento: Wait indicators located east and west end "R" Street overpass near Front Street.

1. Eastward and westward trains must stop at "W" indicator.
- *2. Operation of pushbutton will extinguish "W" indicator and flashing white light will authorize movement over structure to opposing "W" indicator.
3. After receiving flashing white light and movement over structure is not made, cancel button is provided.
4. Should "W" indicator be found extinguished or flashing white light cannot be activated by operation of pushbutton, movements must be made with caution protecting against opposing trains.

*Pushbutton box located on case of "W" indicator. Advance pushbutton provided east of Third Street for westward movements to minimize blocking Third Street crossing.

EASTWARD ON NO. 2 TRACK

Illum. On Letter Signal	Approaching	Authorizes and requires movement as follows:
----------------------------	-------------	---

S 1404 Colfax Enter siding and contact train dispatcher.

W 1688 . . . *Emigrant Gap. When letter "W" is illuminated, train must stop and not proceed until indicator is extinguished.

P 7-ft. Mast
MP 241.69. Reno Eastward trains and engines must stop west of Keystone Avenue, Reno, MP 242.11, unless indicator light unit mounted on mast, MP 241.69, displays letter "P" or authority is obtained from the Yardmaster and his instructions followed.

WESTWARD ON NO. 1 TRACK

S 2091 Truckee Enter westward siding and contact operator Norden.

W 2027 . . . **Andover

W 2029 . . . **Andover

W 2083 . . . **Truckee

*When eastward train finds Signal 1688 displaying stop indication and "W" letter type indicator not illuminated, member of train crew must contact operator Norden and be governed by his instructions before proceeding.

**When letter "W" is illuminated, train must stop and not proceed until indicator is extinguished.

When westward train finds Signal 2029, 2027 or 2083 displaying stop indication and "W" letter type indicator not illuminated, member of train crew must contact operator Norden and be governed by his instructions before proceeding.

RULE 509. Roseville: Westward freight trains and engines from Roseville Subdivision, after receiving proceed signal or oral authorization from switchman, may pass Signal 1065 displaying stop indication without stopping when movement is to be made into yard tracks.

GENERAL REGULATIONS

RULE 825. Sacramento: Not less than three hand brakes must be applied on west end of cars or trains on Tracks 2 through 9, incl. Not less than two hand brakes must be applied on east end of cars or trains on Tracks 13 through 27, incl. Not less than three hand brakes must be applied on west end of cars or trains on north and south Levee Tracks.

Roseville: Unless otherwise instructed by Yardmaster not less than five (geared type) hand brakes must be applied on cars or trains of fifty cars or more; not less than three (geared type) hand brakes must be applied on cars or trains of less than fifty cars on the following tracks Roseville Terminal:

- East End—Tracks 1 through 25, incl., Receiving Yard.
- West End—Tracks 50 through 84, incl., Departure Yard.
- West End—Tracks 50 through 84, incl., Departure Yard.
- West End—Track 21, Departure Yard.
- East End—All tracks in PFE repair yard, incl., Tracks 90 and 91.

Five (geared type) hand brakes must be applied on west end and three (geared type) hand brakes must be applied on east end of all eastward trains arriving in Roseville Departure Yard.

Portable rail skids are hung on posts at the following locations:

- | | |
|---------------------------|---|
| Bowman | { West end siding.
West end storage track. |
| Colfax | West end sidings. |
| Gold Run | { West end siding.
West end set-out spur. |
| Towle | Spur track. |
| Midas | East & west end spurs. |

SPECIAL INSTRUCTIONS—ROSEVILLE SUBDIVISION

Emigrant Gap	West end siding.
Norden	{ Train order delivery post. No. 1 turntable lead.
Summit	Spur track.
Truckee	Team track.
Verdi	At crossover.

Refer to Rule 825, All Subdivisions.

RULE 827. DRAGGING AND / OR DERAILED EQUIPMENT DETECTOR AND INDICATOR INSTALLED AT THE FOLLOWING LOCATIONS:

LOCATION	SIGNAL	PROTECTS DIRECTION(S)	ON TRACK
At Signal	995	Both	#1
Mile Post	110.2	Both	#1
At Signal	1168	Both	#2
At Signal	1187	Both	#1
At Signal	1214	Both	#2
At Signal	1219	Both	#1
At Signal	1258	Both	#2
At Signal	1277	Both	#1
Mile Post	131.2	Both	#1
At Signal	1374	Both	#2
At Signal	1452	Both	#2
Mile Post	W.B. 145.6	Both	#1
Mile Post	E.B. 150.0	Both	#2
Mile Post	W.B. 150.4	Both	#1
At Signal	1546	Both	#2
Mile Post	W.B. 155.1	Both	#1
At Signal	1582	Both	#2
At Signal	1591	Both	#1
At Signal	1630	Both	#2
At Signal	1635	Both	#1
At Signal	1668	Both	#2
At Signal	1687	Both	#1
On Signal	1756	Both	#2
On Signal	1757	Both	#1
On Signal	1823	Both	#1
On Signal	1824	Both	#2
On Signal	1900	Both	#2
On Signal	1901	Both	#1
At Signal	1941	Both	#1
Mile Post	195.0	Both	#1
Mile Post	195.3	Both	#2
At Signal	1958	Both	#1
On Signal	2023	Both	#1
On Signal	2024	Both	#2
On Signal	2039	Both	#1
On Signal	2040	Both	#2
On Signal	2124	Both	#2
On Signal	2125	Both	#1
On Signal	2180	Both	#2
On Signal	2201	Both	#1
At Signal	2239	Both	#1
At Signal	2280	Both	#2
At Signal	2350	Both	#2
At Signal	2351	Both	#1
Mile Post	240.0	Both	#2
Mile Post	240.0	Both	#1

HOT BOX DETECTORS

Illum.	On	Letter Signal	Approaching	Location of Readout
H	1421	Colfax		West End Colfax MP 141.55
W	1431	Colfax*		

*When letter "W" is illuminated, train must stop. Member of train crew must contact train dispatcher before proceeding and be governed by his instructions.

SCANNER SITE

MP	Type	Direction(s)	Location
98.3	D	East	Planehaven
110.2	D	West	Rocklin
148.6	C	Both	Magra
143.5	A	West	Colfax-Cape Horn
240.0	D	East	West Reno

Refer to Rule 827, All Subdivisions.

RULE 834-A. Sacramento: Excess width or height loads must not be operated on Sacramento Passenger Station Track 4. Employees must not ride on top or side of engines or cars on Track 4.

RULE 837. Roseville: Flashing white light installed west of electrically operated switch on Tracks 21-25. Eastward movements, except yard engines, must not be made from Track 21 unless switch is lined and flashing white light is displayed or movement is orally authorized.

Westward trains and engines (except yard engines) using running track must not pass fouling point at west end in vicinity of Dry Creek unless proceed signal received from switchman, yellow flag by day, yellow light by night, or oral authorization or signal received from trainman of the same crew.

Antelope: Eastward trains entering yard track must not pass interlocking office unless proceed signal or oral authorization received from switchman.

RULE 845. Roseville: Conductor will be responsible for ascertaining when his train is made up. He will then instruct his crew to proceed to make-up track to prepare train for departure.

RULE 872. Roseville Diesel Facility, Sacramento and Sparks: Enginemen taking charge of road engines will consider engines as having been amply supplied with water, fuel, sand and other supplies.

AIR BRAKE RULES

RULE 2, A. Taking Charge of Engines.

Will apply at:

Roseville, Sacramento and Sparks.

FREIGHT TRAINS

Retaining valves must be used on descending grades as follows:

Norden to Truckee-Norden to Loomis.

WITHOUT DYNAMIC BRAKE IN OPERATION:

One retaining valve for each 80 tons in train. If gross tonnage exceeds 80 tons per operative brake, retaining valves must be used on all cars and speed must not exceed 15 MPH.

WITH DYNAMIC BRAKE IN OPERATION:

Permissible Tons Per Unit Without Retaining Valve

	Basic-Dynamic Brake		Extended Range Dynamic Brake		
	4 Axle	6 Axle	4 Axle	6 Axle	8 Axle
With dynamic brake in operation but without pressure maintaining system of braking:	650	940	800	1200	1600
Norden to Truckee	450	650	550	850	1125
Norden to Loomis					
With dynamic brake in operation and with pressure maintaining system of braking:	1800	2700	2300	3500	4600
Norden to Truckee	1400	2100	1700	2600	3400
Norden to Loomis					

With dynamic brake in operation but without pressure maintaining system of braking:

Norden to Truckee 650 940 800 1200 1600
Norden to Loomis 450 650 550 850 1125

With dynamic brake in operation and with pressure maintaining system of braking:

Norden to Truckee 1800 2700 2300 3500 4600
Norden to Loomis 1400 2100 1700 2600 3400

If permissible tonnage is exceeded, one retaining valve must be used for each 150 tons in excess thereof.

Freight trains without dynamic brakes in operation will stop at the following stations for at least 10 minutes for wheel heat radiation:

Eastward	Westward
MP 203.0	Troy Emigrant Gap Midas Gold Run Bowman

Train inspection must be made as prescribed by Rule 827 at all wheel heat radiation stops.

Refer to Air Brake Rule 17, All Subdivisions.

RULE 24. Will apply at Roseville.

RULE 24-E. Will apply to trains arriving Roseville.

RULE 24-G. Will apply at Sparks.

RULE 25. Will apply at Norden when required to stop and make train air brake test at that point, except:

Rule 25-A. Will apply at Crystal Lake eastward or approaching MP 209.2 Westward.

Rule 25-B. Will apply to westward freight trains immediately after rear of train leaves portal of Tunnel 6 or 41 and before reaching station at Norden, and to eastward freight trains immediately after engine passes station at Norden and before engine enters west portal of Tunnel 6 or 41.

If unable to comply with Rules 25-A and/or 25-B, Rule 25 applies.

RULE 33. Norden to Truckee, Boca to Floriston, Verdi to Lawton, Norden to Rocklin.

MAXIMUM TONS PER OPERATIVE BRAKE . . . 80 TONS

Restrictive grades are as follows:

Eastward	MP to	MP	MPH
Norden to Truckee	192.8	210.0	20
Boca to Floriston	219.0	224.0	25
Verdi to Lawton	229.5	240.0	25
Westward			
Norden to Colfax	193.6	143.6	20
West of Colfax	142.0	138.3	25
West of Colfax to East of Loomis	136.5	115.0	20
East of Loomis to Rocklin	115.0	111.3	25

Exceptions:

Trains with not more than 425 tons per axle of dynamic brake, pressure maintaining system of braking in operation and speed not exceeding 25 miles per hour:

MAXIMUM TONS PER OPERATIVE BRAKE 100 TONS

Trains handling loaded crude oil cars only with not more than 250 tons per axle of dynamic brake, pressure maintaining system of braking in operation, not more than 90 cars and speed not exceeding 25 miles per hour:

MAXIMUM TONS PER OPERATIVE BRAKE 130 TONS

Trains handling loaded crude oil cars only with not more than 300 tons per axle of dynamic brake, pressure maintaining system of braking in operation, not more than 90 cars and speed not exceeding 20 miles per hour:

MAXIMUM TONS PER OPERATIVE BRAKE 130 TONS

Norden to Truckee, Norden to Rocklin

Should dynamic brake failure occur while handling in excess of 80 tons per operative brake, train may proceed at speed not exceeding 15 MPH if in judgment of the conductor and engineer it is safe to do so and provided retaining valves are used as prescribed by Air Brake Rule 17.

PASSENGER TRAINS

RULE 17. Norden to Truckee-Norden to Loomis:

Without dynamic brake in operation turn up all accessible retaining valves.

RULE 39. Running test must be made on eastward passenger trains in the vicinity of MP 191.0 approaching Norden.

Running test must be made on westward passenger trains just after emerging from Tunnel No. 41 on No. 2 Track; or, in the vicinity of MP 196.7, where No. 1 Track crosses east portal of Tunnel No. 41 on the No. 1 Track.

MISCELLANEOUS

1. Sacramento: Communicating signal will be used to start passenger train at Sacramento.

2. Engines listed must not operate on tracks shown below:

Class of Engine	Restricted Tracks
All engines	Newcastle—Over trestle portion of fruit spurs.
All engines	Summit—Lumber spurs Nos. 3 and 4 beyond derail.

3. LOAD LIMIT (car and contents):

*Sacramento-Sparks	315,000 pounds
Sacramento-Hood	240,000 pounds
Sacramento-Brighton via R St.	240,000 pounds

*Refer to All Subdivisions, Page 20, Miscellaneous Item No. 14.

4. OPERATION OF TURNABLES

Norden: Turntable equipped with rail locks each end. Before moving onto table from any lead, table must be lined so engine will enter from locked end only. Engines when backing and approaching table from lead from eastward siding, will stop to clear table and member of crew after properly lining and locking table will signal engineer to move onto table by green light controlled by pushing button located on post of turntable shed on engineer's side. This signal does not indicate position of turntable or turntable lock. Engines leaving turntable will leave from locked end. In making movements to or from turntable it will not be necessary to lock opposite end of table.

Turntable must not be moved until engineer signals fireman engine is properly spotted and brakes applied.

Engineer or member of crew, preferably engineer, must remain in the cab of engine at all times when engines are being turned at Norden.

5. Balloon track at MP 169.16, west of Emigrant Gap, diverging from No. 1 Track. Crossover between main tracks located at east end of balloon track at MP 169.55. Engines and equipment will enter balloon track at west switch and leave balloon track at east switch.

6. Sacramento: Operation over SNRY: Rail connection to the Yolo Port in Sacramento Yard from the clearance point at Washington to the Port Railroad connection at Riske Lane is used jointly by SNRY and SP crews. Movement on joint track governed by block signals whose indications supersede the superiority of trains.

Block indicators located at switches indicate track occupancy.

When block indicator shows block clear, switch may be reversed and movement made after block signal displays a yellow aspect.

If block indicator shows block occupied, switch must not be reversed until it has been ascertained that there is no opposing or conflicting movement.

If after switch has been reversed signal displays stop indication, train or engine must wait five minutes and then be preceded by flagman through joint track area.

Maximum speed permitted on joint track is 10 MPH and all movements must be made with caution.

SPECIAL INSTRUCTIONS—ROSEVILLE SUBDIVISION

Normal position of switches connecting with joint track is as follows:

SNRY Woodland Branch connection just west of West Capitol Ave. underpass lined for Yolo Port Railroad.

East wye switch SNRY Woodland Branch for movement west leg of wye.

Sacramento Yolo Port Railroad connection just east of county road crossing for SNRY west leg of wye.

Sacramento Yolo Port Railroad yard tracks are used jointly by SNRY and SP crews and all movements must be made with caution not exceeding 10 MPH.

Flag protection to the rear is not required when operating in joint track area or over Sacramento Yolo Port Railroad yard tracks.

7. Air flow curtain installed East portal tunnel No. 28, MP 135.36, No. 2 track, Applegate.

Curtain is designed to actuate and close only if speed of train is 20 MPH or less when passing MP 134.1. Under above conditions train must not increase speed in excess of 20 MPH after passing MP 134.1 until engine passes East portal of tunnel No. 28, MP 135.36.

Air flow curtain installed west portal Tunnel No. 41, MP 193.30, No. 2 Track, Norden.

Curtain is designed to actuate and close only if speed of train is 20 MPH or less when passing westward Signal 1965, No. 2 Track, Eder.

Under above conditions train must not increase speed in excess of 20 MPH after passing Signal 1965 until engine passes west portal of Tunnel No. 41, MP 193.30.

SPEED RESTRICTIONS FOR TRAINS: Maximum speed of trains in territory shown below is subject to further restrictions applicable to engines in the train as shown in **SPEED RESTRICTIONS FOR ENGINES** appearing on pages 18 and 19 and **MAXIMUM SPEED PERMITTED WITH CERTAIN EQUIPMENT** and **OTHER MAXIMUM SPEEDS** appearing on page 21 of Timetable for All Subdivisions. Speed must be further reduced as prescribed by speed signs, except as specifically authorized by Special Instructions herein, or by timetable bulletin.

Trains handling tank cars containing Flammable Compressed Gas must not exceed 55 miles per hour. Where maximum authorized speed is less than 55 MPH and more than 25 MPH, train must be operated at 5 MPH less than maximum authorized speed and must not exceed 30 MPH at the following locations:

No. 2 Track, Sacramento to Sparks:

Sacramento	MP 90.0 to MP 91.6
Elvas-Roseville	MP 92.5 to MP 106.8
Roseville-Penryn	MP 106.7 to MP 111.0
Newcastle	MP 119.8 to MP 120.5
Auburn	MP 123.5 to MP 125.3
Verdi	MP 231.5 to MP 232.0

No. 1 Track, Sparks to Sacramento:

Verdi	MP 232.5 to MP 231.5
Penryn-Roseville	MP 115.1 to MP 106.7
Roseville-Elvas	MP 106.8 to MP 92.5
Sacramento	MP 91.6 to MP 90.0

At Reno, when engine passes last crossing within limits of restriction in direction of movement, speed may be resumed to that shown on next speed sign.

Freight trains must not exceed 20 MPH (westward) from MP 192.10 (Norden) to MP 113.26 (Loomis) and (eastward) from MP 192.00 (Norden) to MP 209.10 (Truckee) when retaining valves required in accordance with Air Brake Rule 17.

Engines with flanger may operate at speeds shown in Column 1 not exceeding 40 MPH and between Colfax and Truckee may operate at 35 MPH.

Maximum authorized speed for freight trains is 55 MPH.

EASTWARD			PSGR TRAINS	FRT	WESTWARD			PSGR TRAINS	FRT
MP	MP	Column:	1	2	MP	MP	Column:	1	2
SACRAMENTO to SPARKS:					SPARKS to SACRAMENTO:				
88.54 to 89.20...			10	10	246.20 to 244.16*			30	30
89.20 to 90.00...			25	25	244.16 to 242.20*				
90.00 to 91.61...			35	35	(Reno).....			20	20
91.61 to 92.56 (interlocking and bridge).....			25	25	242.20 to 224.00*..			45	45
92.56 to 93.00...			50	50	224.00 to 208.00*..			40	40
93.00 to 102.50...			70	55	208.00 to 194.00*..			30	30
102.50 to 103.15...			35	35	194.00 to 115.13*..			30	25
103.15 to 106.08...			45	45	115.13 to 108.12*..			40	40
106.08 to 106.74...			15	15	108.12 to 106.74*..			35	30
106.74 to 108.12**			35	35	106.74 to 106.08...			15	15
108.12 to 113.00**			70	55	106.08 to 102.50...			45	45
113.00 to 141.95**			50	50	102.50 to 93.00...			70	55
141.95 to 193.00**			30	30	93.00 to 91.61 (bridge and interlocking)....			25	25
193.00 to 208.00**			30	25	91.61 to 90.00...			35	35
208.00 to 224.00**			40	40	90.00 to 89.15...			25	25
224.00 to 242.20**			45	45	89.15 to 88.54...			10	10
242.20 to 244.16** (Reno).....			20	20					
244.16 to 246.20**			30	30					
*No. 1 Track									
**No. 2 Track									
SACRAMENTO to ISLETON:					ISLETON to SACRAMENTO:				
89.59 to 92.40...				20	104.60 to 92.40...				10
92.40 to 104.60...				10	92.40 to 89.59...				20

EXCEPTIONS:

- (a) Freight trains may operate at Column 1 speeds not exceeding 65 MPH when authorized by train order, provided train contains no restricted cars or empties except cabooses and does not exceed 80 tons per operative brake and/or 120 cars.
- (b) Eastward trains between Norden and Truckee and Westward trains between Norden and Loomis having between 120 and 145 cars may operate at Column 1 speeds provided train has no restricted cars and does not exceed 50 tons per operative brake.
- (c) Eastward trains between Norden and Truckee and westward trains between Norden and Loomis may operate at Column 1 speeds provided train has no restricted cars and does not exceed 80 tons per operative brake and/or 120 cars.

SPEED RESTRICTIONS FOR OTHER THAN MAIN TRACKS With Caution Not Exceeding MPH

Through sidings, yard and other tracks, wyes, balloon tracks, slip switches, crossovers and turnouts.....	10
Except:	
Through power crossovers, Truckee.....	25
Through crossover, Shed 47.....	25
Westward through crossover, Norden, from No. 2 to No. 1 Track.....	25
Through siding Norden (and turnouts).....	20

RULE P. LOCATION OF OVERHEAD AND SIDE STRUCTURES NOT STANDARD CLEARANCE ON MAIN TRACK AND SIDINGS

MP	Location	Description
(POLK-ELVAS)		
133.13	Brighton	Signal bridge . Overhead
(PLACERVILLE BRANCH)		
122.30	East of White Rock	Rock cut Side
126.40	Latrobe	Rock cut Side
126.50	East of Latrobe	Rock cut Side
128.60	East of Latrobe	Rock cut Side

RULE 7-C. Fresno Yard: Trains entering or leaving yard tracks must receive proceed signal from switchman, green flag by day, green light by night, except within limits of diverging route signals, or engineer is orally authorized.

RULE 10-J. Speed may be increased as soon as lead engine has passed increase speed sign at following locations:

Westward MP	Eastward MP
102.80	Lodi 103.65

Speed signs located to left of track in direction of movement:

Westward	Reading	Eastward	Reading
MP 199.28	70-60	MP 72.25	40
		MP 110.60	65-60
		MP 147.70	45

Speed signs to right of track in current of traffic direction with one track intervening:

Westward	Reading	Eastward	Reading
		MP 132.10	40

RULE 80. Polk: CCT trains preparing to enter SP tracks must stop clear of fouling point or derail. Member of crew must contact SP operator at Elvas for permission to enter SP tracks.

RULE 26-B. Lathrop: MP 81.50. Libby Owens Ford Glass Co. Hinged platform has been placed on platform inside building near the end of Track No. 1. Protective signals have been placed on each side of door where track enters building. Trainmen and enginemen must not pass these signals if red indication or no indication is shown. Green indication must be shown before proceeding beyond signals.

Madera. (Winery Spur): MP 187.0. Access to United Vintner's Winery is controlled by gates across track No. 5330 (old main track) and track No. 5360 in advance of tank car loading area, and another gate across track No. 5361 in advance of shipping area. A member of train crew must gain access by calling Security Guard on the intra-plant telephone.

At United Vintners MP 187.25, the 535 ft. end portion of each of two tracks is inside warehouse and entry is controlled by signals on each side of doorway. Enter only when green light visible. Red light or absence of light indicates "STOP."

Woodbridge: MP 104.8. General Mills Co. Signals have been placed over all tracks at doorways entering buildings. Trainmen and enginemen must not pass these signals if red indication or no indication is shown. Green indication must be shown before proceeding beyond signals.

Ione: MP 138.8. Interpace Corp. Track. Signal has been placed at retractable loading ramp with red aspect indicating ramp in position. Trainmen and enginemen must not pass signal displaying red indication. Green aspect must be showing before proceeding beyond retractable loading ramp.

RULE 82-A. Train orders and clearances issued on the Roseville Subdivision will apply on the Stockton Subdivision and vice versa.

RULE 83-A. At the following stations only trains indicated will register:

Galt	Trains via Ione Branch originating or terminating.
Victor	Trains beyond Victor via Kentucky House Branch.
Stockton	Trains via Oakdale Branch originating or terminating.
Ingle	Trains required by train order.
Biola Jct.	Trains via Biola Branch originating or terminating.

Stockton: Trainmen and enginemen should be on the lookout for messages to be picked up if light is showing in Train-Order stand.

RULE 93. Yard limits are established at the following locations:

West MP	East MP
78.50	Tracy (Martinez-West Side Line) 85.64
66.50	Tracy (Niles-Polk Line) 75.81
99.10	Westley 101.10
105.85	Patterson 108.62
112.00	Crows Landing 114.50
117.95	Newman 121.05
122.50	Gustine 124.60
132.90	Los Banos 142.01
152.20	Dos Palos 155.00
164.94	Firebaugh-Mendota 178.50
181.10	Ingle 182.50
	Ingle (Riverdale Branch) End of track
192.46	Kerman 194.53
202.00	Fresno (West Side Line)
199.34	Fresno (East Side Line) 209.00
208.44	Fresno (Biola Branch)
82.15	Stockton 92.17
	Stockton (Oakdale Branch) 94.40
103.53	Lodi (Kentucky House Branch) 107.50
103.51	Lodi (Woodbridge Branch) End of track
	Sacramento (Placerville Branch) 97.00
131.60	Sacramento (East Side Line) 136.33
103.80	Citrus 105.26
110.57	Folsom Jct. 111.38
148.19	Placerville End of Branch

Oakdale: Trains and engines must move with caution between F and G Streets expecting to find main track occupied by Sierra Ry. trains or engines.

RULE 97. Fresno Yard: Westward extra trains originating Fresno Yard to operate via Valley Line need not obtain train order authority but must obtain a clearance.

RULE D-97. Applies on both main tracks between Lathrop (MP 81.30) and El Pinal (MP 92.32).

RULE 98. Railroad crossings at grade not interlocked:

Trains and engines must approach with caution, and may move over the following crossings without stopping, if crossing clear and no movement approaching on intersecting line:

Stockton CCT Co., crossing of Oakdale Branch near MP 92.0.

Stop clear of the following crossings, then proceed if no movement approaching on intersecting line:

Brandywine CCT Co., crossing of Kentucky House Branch.

Oakdale ATSF, crossing of Oakdale Branch.

MP 116.7 on Ione Branch CCT Co., crossing of Ione Branch.

SPECIAL INSTRUCTIONS—STOCKTON SUBDIVISION

RULE 99-C. Will apply on Placerville Branch.

RULE 103. Automatic warning devices (controlled by single track circuit with "STOP" signs at control limits) exists at following crossings:

Location	Crossing No.	Track	Protection
Manteca	B-96.9	Yard	Gates
Calla	*B-98.52-C	Spreckels	Gates
Salida	B-106.4	Spur	Gates
Modesto	*B-112.3	Stor.; #2 Siding	Gates
Livingston	B-136.5	Drill track	Gates
Madera	#B-183.9-C	Spur	Fl. Lights
Firebaugh	BA-166.2	Siding	Gates
Firebaugh	BA-168.6-C	Britton	Fl. Lights
Cromir	BA-170.2	Drill	Gates
Kerman	BA-193.5	Siding	Gates
Tomspur	#D-98.1	Spur	Gates
Oakdale	DC-122.3	House	Gates
Rancho Seco	DG-124.3-C	SMUD Spur	Gates
Stockton (Port)	DK-92.41-C	Spur	Gates

*Westward movements only.
#PUC Order.

Members of crew should assure themselves that crossing warning device is operating (and gates are down where they exist) before entering crossing or that warning is afforded by member of crew at crossing.

Los Banos: Crossing gates installed on crossings Mercy Springs Road, MP-141.2, and State Highway MP-141.3. Trains or engines switching in this area must not enter crossing until revolving yellow beacon, located on mast on north side of track between the two crossings, is actuated.

Turlock: City ordinance requires that in event of fire alarm being sounded, any train blocking Main St., MP-126.1, must clear crossing immediately. Switching must not be done over Main and Olive Street crossings between hours of 12 Noon and 1:00 PM.

No switching to be performed over Marshall Street except for spotting or removing of cars to or from industries served by these tracks.

Madera: Eastward through freight trains when stopping to set out, leave train clear of Central Avenue crossing, MP-183.3, and westward through freight trains clear of Olive Avenue crossing, MP-184.5.

Madera (Winery spur): Traffic signals at Howard Road (Crossing No. B-184.6-C) and adjacent Pine Street are preempted by train operation between stop signs installed each side of Howard Road crossing. On approach to crossing trains are to be brought to a stop. When traffic signals are in operation, trains are not to proceed until traffic signals show a flashing red aspect. When traffic signals are not in operation, trains are not to proceed until it is known crossing is clear or until warning is afforded to traffic by member of the crew.

Fresno: Eastward freight trains changing crews at Fresno, must stop to clear insulated joints located just west of Tulare Street unless otherwise instructed by yardmaster or his representative.

At the following locations, trains moving under the provisions of Rules 771 and 776 must not enter the crossing until warning for vehicular traffic has been afforded by a member of the crew, or it is known that automatic warning devices are operating:

Station	Location	MP
Lathrop	Lathrop Road	82.1
Modesto	Butchertown Spur	114.7
Turlock	Fulkerth Road	124.9
Arena	West Siding Switch (Arena Way)	139.0
Merced	"D" Street	151.3
Chowchilla	West Siding Switch (King St.)	168.0
Chowchilla	West Siding Switch (Robertson Blvd.)	168.1
Biola Jct.	Biola Branch (Old Highway 99)	208.5
Lodi	Woodbridge Rd.	105.1
Lodi	Lodi Ave.	102.1

Public Utilities Commission orders prohibit operation of train, engine, motor or car over the following crossings unless first brought to a stop and warning is afforded to traffic on the highway by a member of the crew:

Lodi	Crossing Oak St., D-103.25, and Pine St., D-103.3 on yard tracks,
Woodbridge	Crossing Turner Road on General Mills spur, DE-105.3-C,
Carbondale	Crossing County road when on industry track, DG-132.1,
Modesto	Tully Ave., on Grange Co. spur, B-112.25-C,
Vernalis	Crossing on Spur No. 6890, BA-93.0,
Los Banos	Crossing 2nd and 4th Sts., on drill crossovers and storage tracks, BA-140.1, BA-140.2,
Firebaugh	Crossing 12th St., on drill and spur tracks, BA-166.2.
Helm	County road crossing on Spreckels Sugar Co. track, BAO-199.1.

RULE 104. The normal position of rigid switches at the end of double track and at junctions, is as follows:

Ingle	Riverdale Branch, for Branch.
Fresno Yard	End double track, for westward track.
Fresno	West Side Line, for eastward main track. Stem of Wye for West Leg Wye.
Lodi	Woodbridge Branch, for Lathrop line. Yard track, for Kentucky House Branch.
Citrus	Fair Oaks Branch, for Placerville Branch.
Folsom	Junction . Folsom Branch, for Placerville Branch.

Derails on main track.

Location	MP
Kentucky House	142.2

Madera. (Winery spur): Derail installed 100 ft. ahead of gates at Madera Glass Company plant to protect LPG tank car unloading. Do not close derail nor enter plant to do switching until it has been determined that no tank car is connected for unloading.

RULE 104-A. Tracy: Westward freight trains approaching east end Tracy Yard must run expecting to find main track switch lined for movement into yard tracks.

Yellow switch targets and keepers have been installed on main track switches at the ends of the following branch lines:

Kentucky House Branch	MP-142.6, Kentucky House
Biola Branch	MP-200.5, Biola
Riverdale Branch	MP-214.6, Riverdale

RULE 104-D. Modesto: Under no circumstances are cars to be kicked or dropped into tracks serving Food Machinery Corporation Plant.

RULE 105. Manteca-Calla:

Manteca: Track No. 1 extends from MP 96.73 to MP 92.72.

Calla siding extends from MP 97.74 to MP 99.44, is CTC controlled siding, capacity 8350 ft. Crossover at west end Calla siding is equipped with dual control switch machines.

Calla: Westward absolute siding signal at west end siding is three-unit signal and governs movement as follows:

Top unit	To Manteca Track No. 1.
Center unit	To main track.
Lower unit	To Manteca Track No. 1.

RULE 221. Fresno Yard: Is a train-order office only for trains originating.

RULE S-240. MOVEMENT OF TRAINS BY STAFF SYSTEM.

Applies at following location(s):

Territory	Register Location
-----------	-------------------

- Oakdale Branch:**
 MP 94.40 to Montpellier.....Stockton
- Kentucky House Branch:**
 MP 107.50 to Kentucky House.....Victor
- Ione Branch:**
 MP 112.10 to Ione.....Galt
- Biola Branch:**
 MP 208.44 to Biola.....Biola Jct.

RULE D-251: Will apply:

- On eastward track: Lathrop to MP 92.2.
- On westward track: MP 92.2 to MP 81.24.
- On both tracks between Fresno Yard and Calwa Tower.

RULE 291. Lathrop: Flashing yellow aspect governs movements to east or west leg of wye at Fresno end of wye.

RULE 306. The following home signals equipped with triangular plate bearing the letter "P" have included in their control limits some special protective device. Absolute and interlocking signals are listed as "P-A," "P-SA" or "P-I."

Eastward Signal	Protection	Westward Signal
TRACY-FRESNO (WEST SIDE LINE)		
P-710	Spring switch, junction to West side Line, Tracy	
	Spring switch to yard, Tracy.....	P-829
P-2046	Barricade detector, MP-204.60, Fresno.....	P-2051
TRACY-POLK LINE		
	Spring switch to Freight Lead, MP-75.9 (Polk Line).....	P-SA
	Spring switch, Stockton wye.....	P-I
LATHROP-FRESNO (EAST SIDE LINE)		
P-1972	Spring switch, Crossover Biola Jct.....	P-A
P-2042	Barricade detector, MP 204.6	
P-A	Barricade detector, MP 109.5.....	P-A

AUTOMATIC BLOCK SIGNAL SYSTEM

RULE 505. Tracy: Trains moving on main track in either direction will move between junction switch MP 70.62 and P-SA Signal MP 75.9, beginning CTC, by block signals whose indications will supersede the superiority of trains.

Signal P-710 is a two unit signal and governs movement as follows:

- Top Unit.....To Lathrop
- Bottom Unit.....To Los Banos

Signals 713, 825 and 827 are approach clearing. Signal 713 will revert to stop position when 600-ft. track circuit in front of station building is occupied for approximately four minutes. A second approach circuit is located at MP 71.39, 185 feet east of MacArthur Blvd., to clear Signal 713 for movements to be continued.

Approach circuit to Signal 825 on Track No. 1 begins 185 feet east of MacArthur Blvd.

Approach circuit sign is north of main track 185 feet east of MacArthur Blvd.

Signal P-829 is a two unit signal and governs movement as follows:

- Top Unit.....To Main Track
- Bottom Unit.....To Yard

Signals 716 and 723 on Track No. 1 at crossover near MP 72 govern movements over crossovers to enter main track only. These signals will not be lighted when crossovers are lined normal. Time circuits are provided to cut out west control of Signal 716, 2 minutes and 40 seconds after crossover is lined; east control of Signal 723, 6 minutes and 10 seconds after crossover is lined; and west control of Signal 736, 5 minutes and 20 seconds after crossover is lined. If signals fail to clear at expiration of time interval, Rule 507 will govern.

Signal 735 is a two unit signal and governs movement as follows:

- Top Unit.....On Main Track
- Bottom Unit.....To Yard Thru Cross Over

Signal 736 on Track No. 1 is a three unit signal and governs movement as follows:

- Top Unit.....To Freight Lead
- Center Unit.....To Main Track
- Bottom Unit.....To Freight Lead

Eastward trains moving on main track must not pass Signal 734 and eastward trains entering main track through crossover MP 73.5 must not pass Signal 736 until signal governing movement displays proceed indication or permission obtained from train dispatcher. When Signal 734 displays proceed indications, eastward trains on main track may proceed to Centralized Traffic Control limits MP 75.81, and when Signal 736 displays proceed indication, eastward trains entering main track through crossover are authorized to enter main track and proceed to Centralized Traffic Control limits MP 75.81.

When westward P-SA Signal at MP 75.9 displays proceed indication, westward trains are authorized to proceed on main track to Signal 735, Tracy Yard.

When Signal 816, approach signal to West End Tracy displays stop indication, eastward trains may proceed after receiving oral authority from operator at Tracy but must comply with Rule 507.

Push buttons are located on Signal 827 on West Side Line, and instrument case east of MacArthur Blvd. on East Side line to clear signals over junction switch.

Push buttons are located on instrument case opposite Signals 828 and 826, West Side line, west of spring switch to yard.

RULE 509. Fresno: Trains from Fresno Yard to operate via West Side Line may pass Signal 2036 displaying stop indication without stopping at restricted speed to enter west leg of wye if wye switch is properly lined and proceed signal received from switchman or oral authorization is given.

SPRING SWITCHES

RULE 538. Spring switches equipped with facing point locks are located as follows:

Station	Location	Normal Position
Tracy.....	Junction switch MP-71.16 to West Side Line.....	East Side Line
Tracy.....	MP-75.9 Freight Lead to Main Track.....	Main Track

Spring switches not equipped with facing point locks are located as follows:

Station	Location	Normal Position
Biola Jct.....	East Switch of Crossover.....	Freight Lead
Tracy.....	MP 82.98 West Side Line to yard.....	Yard Track
*Stockton.....	West Leg of Wye.....	West Leg of Wye

*Has ground throw switch stand below plate at switch. Not equipped with target bearing letters "SS."

Switch point indicator located at:

Fresno Yard....Spring switch leading from Freight Lead to Track No. 31 west of Ashlan Avenue.

INTERLOCKING

RULE 606. Tracy: Limits extend from westward SA Signal at MP 70.68 to eastward SA Signal at MP 70.64 on the Niles Line and from MP 70.68 to eastward SA Signal at MP 82.18 on the Martinez Line.

Position of the junction switch between Niles Subdivision MP 70.66 and Martinez Subdivision MP 82.16 controlled by switchman from control panel located at the base of the yardmaster's tower.

The junction switch between Niles Line MP 70.66 and Martinez Line MP 82.16 is a dual control switch. When necessary to hand throw this switch, permission must be obtained from the yardmaster and be governed by Rules 771 and 772.

Interlocking portion of the SA signal is controlled by Tracy operator who shall determine that switch has been lined for proper route before clearing a signal.

SPECIAL INSTRUCTIONS—STOCKTON SUBDIVISION

Stockton: WP crossing Weber Avenue and Union St.: Signals governing movements over WP track at MP 91.00 are under control of WP train dispatcher. When signals governing movement over crossing display stop indication after approach circuit is occupied or if signal governing movements out of Building Materials Distributors spur does not display proceed indication after switch and derail have been lined, a member of crew must contact WP train dispatcher for permission and instructions to operate push button time release.

Eastward trains via Oakdale Branch must not leave yard until authorized by yardmaster or his representative.

Elvas: Limits extend on East Side Line to interlocking signal at west switch Polk; and on Placerville Branch to interlocking signal 600 feet east of junction switch at Brighton.

Following switches are equipped with electric switch locks and must not be operated until permission has been obtained from operator whose instructions will govern movements not controlled by signal indicator:

Elvas West end of center siding.
Hopfen spur Switch.
R Street industrial track Switch.
Black Diamond Lumber Co. Switch.

Switches will not be lined for movement to Polk siding without first obtaining permission from operator.

Polk: West switch and eastward signals operated by interlocking operator at Elvas, and their use governed by special instructions, Roseville Subdivision.

Movements governed by dwarf signals must be made with caution and position of switches observed, as such signals govern movements for various routes.

Dual control switches within interlocking limits are under the control of operator. When necessary to hand-throw these switches, permission must be obtained from operator and be governed by Rules 771 and 772.

AUTOMATIC INTERLOCKING

RULE 680. French Camp, WP Crossing MP 87.74. Interlocking limits: Interlocking signals 500 feet west of and 430 feet east of WP crossing on eastward main track. Interlocking signals 430 feet east of and 380 feet west of WP crossing on westward main track. Interlocking signals 240 feet west of and 210 feet east of WP crossing on the drill track.

Lyoth: WP crossing, MP 85.16. Limits extend from eastward SA Signal 825 feet west of crossing to westward SA Signal 590 feet east of crossing.

Signals are approach clearing, if movement over crossing is not completed within 8 minutes after train enters approach circuit, signals will revert to STOP position. Approach circuits to re-clear SA signals are located 800 feet in advance of eastward signal and 500 feet in advance of westward signal.

Cars or engines are not to be left standing on these circuits.

Push button time release in box marked "SP" and block indicator marked "WP" are installed near crossing.

Instructions for operating time release are posted in box.

If signal indicates STOP for train desiring to make movement over crossing, a member of crew will proceed to crossing to operate time release. If block indicator marked "WP" indicates block clear, press push button until yellow light appears, then release. Approximately 8 minutes later a red light should appear under the button and signal indicate proceed.

If signal displays flashing red indication train may proceed through interlocking limits.

If home signal indicates STOP and red indicator light cannot be actuated, train may proceed over crossing as provided for in Rule 663(c).

LETTER-TYPE INDICATORS

RULE 705. Indicators located as follows:

Illum. Letter	On Signal Approaching	Authorizes and Requires Movement as Follows:
S	Post at east switch Covell West Modesto	Take siding at West Modesto
S	Absolute Signal MP 114.9 Modesto	Take siding at West Modesto

CENTRALIZED TRAFFIC CONTROL

RULE 760. Limits extend from eastward absolute signals at MP 75.81 on Tracy Line and westward absolute signal at MP 82.15 on Polk Line at Lathrop, to westward absolute signal at MP 199.32 at Biola Junction on East Side Line.

Lathrop: Eastward 3 unit signal MP 81.30 (west junction switch) governs movements as follows:

Top unit eastward main track
Center unit East Side Line
Bottom unit westward main track
Flashing yellow,
Rule 291 westward main track or East Side Line.

Westward 3 unit signal MP 82.15 governs movements as follows:

Top unit westward main track
Center unit East Side Line
Bottom unit eastward main track

Movements across WP MP 93.72 under control of SP train dispatcher.

When absolute signals governing movements over crossing display "STOP" indication, member of the train crew must contact train dispatcher by telephone for instructions.

If signal cannot be cleared and there is no train approaching from either direction on WP, train dispatcher may authorize member of crew to operate push-button time release in accordance with instructions in box marked "SP" located near the crossing.

Movements in an eastward direction to westward main track east of crossover at MP 82.15 will be governed by the following:

Moves will be controlled by dispatcher after member of crew contacts and receives permission to make move. Dispatcher will line switches and initiate signal. To clear signal member of crew will activate push-button located in control box mounted on pole adjacent to signal in vicinity of MP 82.15. Controlled moves are as follows:

1. To make move from East Side Line through cross-over to westward main track activate right hand push-button labeled 28RDPB and signal should clear.
2. To make move from eastward main track through crossover to westward main track, activate center push-button labeled 28RBPB and signal should clear.
3. To make eastward move on westward main track, activate left hand push-button labeled 30RPB and signal should clear.

Modesto: Movements across TS Ry., MP 114.70, on main track and MP 114.92 on Butchertown Spur under control of SP train dispatcher.

When absolute signals governing movements over crossing display stop indication, member of train crew must contact train dispatcher by telephone for instructions.

If signal cannot be cleared for main track movement and there is no train approaching from either direction on TS Ry., train dispatcher may authorize member of crew to operate push-button time release in accordance with instructions in box marked "SP" located near the crossing.

Butchertown Spur Movements:

Absolute signals on Butchertown spur will not display proceed indication unless main track switch is lined for movement to Butchertown spur.

If signal cannot be cleared for Butchertown movements and there is no train approaching from either direction on TS Ry., train dispatcher may authorize member of crew to operate push-button time-release in accordance with instructions in box located near the main track switch as follows:

Biola Jct.: Westward absolute signal located on lead track governs movements:

- Top unit freight lead extension
- Center unit through crossover to main track
- Bottom unit Biola Branch

El Pinal-Polk: Limits extend from signal at MP 92.30, 650 feet west of WP crossing at El Pinal, to westward signals at MP 131.81 at west end of Polk.

El Pinal: Movements across WP MP 92.30 under control of SP train dispatcher.

When absolute signals governing movements over crossing display "STOP" indication, member of the train crew must contact train dispatcher by telephone for instructions.

If signal cannot be cleared and there is no train approaching from either direction on WP, train dispatcher may authorize member of crew to operate push-button time-release in accordance with instructions in box marked "SP" located near the crossing.

GENERAL REGULATIONS

RULE 812. Main track between Fresno Yard and Chowchilla MP 167.0, including Biola Branch; Fresno Yard and Ingel MP 181.10, including the Riverdale Branch is under the supervision of the Los Angeles Division.

RULE 825. Tracy: All freight trains entering Tracy Yard will apply not less than three hand brakes on the east end unless instructed otherwise by yardmaster.

Portable rail sids are hung on posts at the following locations:

- Placerville (East end team track.
West end interchange tracks.

RULE 827. DRAGGING AND/OR DERAILED EQUIPMENT DETECTOR AND INDICATOR INSTALLED AT THE FOLLOWING LOCATIONS:

MP	Location
*84.0	Lathrop-French Camp
95.5	Lathrop-Manteca
100.0	Tomspur-Lodi
102.3	Calla-Covell
109.1	Acampo-Galt
109.3	Covell-Modesto
116.0	Modesto-Ceres
119.5	Elk Grove-Need
124.5	Ceres-Turlock
125.6	Elk Grove-Florin
132.5	Delhi-Livingston
142.5	Arena-Atwater
152.5	Merced-Lingard
161.2	Lingard-Chowchilla
165.9	Lingard-Chowchilla
187.0	Borden-Irrigosa
193.6	Irrigosa-Biola Jct.

*On both main tracks.

HOT BOX DETECTORS

SCANNER SITE

MP	Type	Directions(s)	Location
97.6	C	Both	Akers-Lodi
119.5	C	Both	Elk Grove-Need
102.3	C	Both	Calla-Covell
121.1	C	Both	Ceres-Turlock
144.7	B	Both	Arena-Fergus
161.2	C	Both	Ligard-Chowchilla
193.6	D	East	*Irrigosa-Biola Jct.
103.6	A	Both	Westley-Patterson

*Recorder at Fresno Yard, Car Foreman's office.

TYPE "A" HOT BOX DETECTOR LETTER TYPE INDICATOR AND READOUT LOCATIONS

Illum. Letter	On Signal	Approaching Location	Readout
H	1019	Westley	MP 99.5 Westley
W	1020	Patterson	
W	1041	Westley	
H	1056	Patterson	MP 106.8 Patterson

Refer to Rule 827, All Subdivisions.

RULE 827-A. Trains handling cars containing Flammable Compressed Gas must stop and inspect train at the following locations:

Eastward Trains	Westward Trains
Irrigosa Crayold	Lyoth

Refer to Rule 827-A, All Subdivisions.

RULE 872. Tracy, Stockton and Fresno: Engine-men taking charge of road engines will consider engines as having been amply supplied with water, fuel, sand and other supplies.

AIR BRAKE RULES

RULE 2, A. Taking Charge of Engines.

Will apply at:

Tracy, Stockton and Fresno Yard.

RULE 17. Retaining valves must be used on freight and mixed trains on descending grades:

Toyon to MP-125.5 (Kentucky House Br.)
MP 131.70 to MP 123.00 (Placerville Br.).

WITHOUT DYNAMIC BRAKE IN OPERATION:

One retaining valve for each 80 tons in train. If gross tonnage exceeds 80 tons per operative brake, retaining valves must be used on all cars, and speed must not exceed 15 MPH.

WITH DYNAMIC BRAKE IN OPERATION:

Permissible Tons Per Unit Without Retaining Valves

	Basic Dynamic Brake		Extended Range Dynamic Brake		
	4-Axle	6-Axle	4-Axle	6-Axle	8-Axle
With dynamic brake in operation without pressure maintaining system of braking Toyon to MP-125.5 (Kentucky House Br.)	525	625	550	950	1250
MP 131.70 to MP 123.00 (Placerville Br.)	600	900	725	1075	1450
With dynamic brake in operation with pressure maintaining system of braking Toyon to MP 125.5 (Kentucky House Br.)	1500	1800	1600	2700	3600
MP 131.70 to MP 123.0 (Placerville Br.)	1500	2250	1800	2700	3600

If permissible tonnage is exceeded, one retaining valve must be used for each 150 tons of excess tonnage.

Refer to Air Brake Rule 17, All Subdivisions.

FREIGHT TRAINS

RULE 21. Coupling caboose and road engine to train will be considered as an indication that train is made up and switchmen have completed their work. Switchmen must not perform switching on or couple other cars to a train on which the road engine and caboose have been attached without instructions from the yardmaster, who will see that members of the crew are notified in advance.

Tracy: Trainmen must not couple air hoses on outgoing trains until train is made up and the caboose and road engine is on train.

RULE 24. Fresno Yard: Will apply only when advised by yardmaster.

RULE 24-C. Tracy: When cars are added to or removed from through trains, with consist otherwise remaining intact, outgoing crew will make air brake test in accordance with this rule.

Ione: Before making any switch movement at Owens-Illinois or Interpace on the Owens-Illinois Lead, it must be known that air brake system on each car being handled is fully charged, air hoses coupled between engine and cars and angle cocks properly positioned.

RULE 24-G. Will apply at Tracy and Fresno Yard.

RULE 25. Will apply at Toyon.

RULE 33. Toyon to MP 125.5 (Kentucky House Br.) MP 131.70 to MP 123.00 (Placerville Br.)

MAXIMUM TONS PER OPERATIVE BRAKE .80 TONS

Restrictive Grades are as follows:

Westward	MP	to MP	MPH
Kentucky House Branch	142.9	142.5	20
	129.1	124.7	20
Placerville Branch	150.0	122.0	20
	117.5	111.7	20

Exceptions:

Trains with not more than 425 tons per axle of dynamic brake, pressure maintaining system of braking in operation and speed not exceeding 20 miles per hour:

Should dynamic brake failure occur while handling in excess of 80 tons per operative brake, train may proceed at speed not exceeding 15 MPH if in judgment of the conductor and engineer it is safe to do so and provided retaining valves are used as prescribed by Air Brake Rule 17.

MISCELLANEOUS

1. LOAD LIMIT (car and contents):

*Tracy-Polk	263,000 pounds
#Tracy-Polk	315,000 pounds
Stockton-Claribell	240,000 pounds
Woodbridge-Kentucky House	240,000 pounds
Galt-Rancho Seco	315,000 pounds
Rancho Seco-Ione	240,000 pounds
*Brighton-Elvas	315,000 pounds
Brighton-Placerville	263,000 pounds
*Lathrop-Fresno	263,000 pounds
#Lathrop-Fresno	315,000 pounds
*Tracy-Fresno via Westside	263,000 pounds
#Tracy-Fresno via Westside	315,000 pounds
*Ingle-Riverdale	263,000 pounds
#Ingle-Riverdale	315,000 pounds
#Biola Jct.-Biola	315,000 pounds

*Applies to uniformly loaded four-axle cars having trucks spaced 23 ft. 0 in. or more center to center and minimum axle spacing of 5 ft. 6 in.

#Applies to uniformly loaded four-axle cars with minimum axle spacing of 6 ft. 0 in. and minimum distance 37 ft. 0 in. center to center of trucks; also, wheels 38 in. or more in diameter.

*Refer to All Subdivisions, Page 21, Miscellaneous item 14.

Unless authorized by Superintendent, heavier loads must not be handled.

2. Stockton: Following will govern movement over ATSF and Stockton Public Belt Railroad:

Limits of Stockton Tower include that portion of main track, siding and crossovers on the ATSF to Stockton Public Belt Railroad, at ATSF MP 1122.97. Signal indications supersede the superiority of trains in both directions on both tracks. At Lincoln Street, MP 1121.75 signals and power switch to Port Lead are controlled from Stockton Tower. Tower telephone located near Lincoln Street signal. West end of Fiberboard support tracks diverge from Port Lead at MP 1121.90 and converge with Port Lead at MP 1122.14. Fiberboard spur track diverges from Port Lead at MP 1122.17. The Washington Street Yard Lead diverges from the Port Lead at MP 1122.20. Crossover also exists between ATSF main track and Port Lead at MP 1122.28. Signals and power switches at crossover are controlled from Stockton Tower. Tower telephone located near east switch of crossover. West end of setout track diverges from Washington Street Yard Lead at MP 1122.21, east end of set-out track converges with Port Lead track at MP 1122.54.

The movement of trains and engines in this territory is under the control of Stockton Tower, who may issue instructions as required and must be advised in advance of any movement of trains and engines to the ATSF main track and also advised of any known condition that will delay the train or engine or prevent it from making usual speed.

Crews will not leave the Port of Stockton yard (in area of yard office) without securing authority of Stockton Tower interlocking operator. This authority may be obtained orally, or through yardmaster at Port of Stockton.

Speed limit between Stockton Tower and Stockton Public Belt Railroad is 20 MPH; through turnouts and crossovers—12 MPH.

Following fixed signals and indications are effective in above specified territory, and between Stockton Tower and ATSF Mormon Yard:

RED.....Stop and communicate with Stockton Tower for instructions.

FLASHING RED.....Proceed prepared to stop short of train, obstruction or switch not properly lined, but not exceeding 20 MPH.

RED OVER YELLOW..Same as flashing red.

S.P. movements entering ATSF interlocking limits at Commerce Street may disregard the letter A on signal governing entrance thereto as it applies to WP movements only.

Following whistle signal will be observed at Stockton Tower:

To and from SP and ATSF yards	0 0 0 -
From SP to ATSF enroute Commerce Street	0 - 0.
For Middle Track	0 - -
For Old Siding	- - 0 0.
For Westward Main Track	0 0 - -
For Eastward Main Track	- 0 - -
From SP to ATSF enroute Lincoln Street	0 - 0 - -

3. Modesto: Set-outs and pick-ups at Modesto to be made as follows:

Storage Track No. 6002.....All Modesto set-outs.

West Pick-ups, West Modesto
Track No. 6032.....Stockton and Roseville.

South Pick-ups, Old Pass
Track No. 6001.....All east cars to Fresno.

SPECIAL INSTRUCTIONS—STOCKTON SUBDIVISION

SPEED RESTRICTIONS FOR TRAINS: Maximum speed of trains in territory shown below is subject to further restrictions applicable to engines in the train as shown in **SPEED RESTRICTIONS FOR ENGINES** appearing on page 19 and **MAXIMUM SPEED PERMITTED WITH CERTAIN EQUIPMENT** and **OTHER MAXIMUM SPEEDS** appearing on page 21 of Timetable for All Subdivisions. Speed must be further reduced as prescribed by speed signs, except as specifically authorized by Special Instructions herein, or by timetable bulletin.

EASTWARD			PSGR TRAINS	FRT	WESTWARD			PSGR TRAINS	FRT
MP	MP	Column:	1	2	MP	MP	Column:	1	2
TRACY to ELVAS:					ELVAS to TRACY:				
71.16 to 72.25			35	35	136.38 to 135.99				
72.25 to 81.30			40	40	(wye from Roseville)			25	25
81.30 to 81.50					136.36 to 135.99				
(switches)			20	20	(wye to Sacramento)			20	20
81.50 to 89.70			70	55	135.99 to 134.10			40	40
89.70 to 91.40			20	20	134.10 to 132.00			70	55
91.40 to 92.32			70	55	132.00 to 103.65			70	55
92.32 to 95.00					103.65 to 102.80			30	30
(via No. 2 Track)			70	55	102.80 to 95.02			70	55
92.32 to 92.36					95.02 to 92.39				
(via No. 1 Track, cross-over)			15	15	(via No. 1 Track)			60	55
92.36 to 95.00					95.02 to 92.43				
(via No. 1 Track)			70	55	(via No. 2 Track)			60	55
95.00 to 95.02					92.43 to 92.39				
(thru turnout)			60	55	(via No. 2 Track, cross-over)			15	15
95.02 to 102.80			70	55	92.39 to 91.40			40	40
102.80 to 103.65			30	30	91.40 to 89.70			20	20
103.65 to 132.00			70	55	89.70 to 81.37			70	55
132.00 to 133.17			70	55	Thru diverging route crossover and switches, Lathrop			25	25
133.17 to 134.10			45	45	81.37 to 72.25			40	40
134.10 to 136.00			40	40	72.25 to 71.16			35	35
136.pp to 136.38									
(wye to Roseville)			25	25					
136.00 to 136.36									
(wye to Sacramento)			20	20					
STOCKTON to CLARIBEL:			ALL TRAINS		CLARIBEL to STOCKTON:			ALL TRAINS	
90.95 to 93.10			12		126.30 to 122.30			25	
93.10 to 94.40			20		122.30 to 122.20			10	
94.40 to 126.30			25		122.20 to 94.40			25	
					94.40 to 93.10			20	
					93.10 to 90.95			12	

BETWEEN		ALL TRAINS	BETWEEN		ALL TRAINS
MP	MP		MP	MP	
LODI and KENTUCKY HOUSE:			GALT and IONE:		
103.51 and 107.50		20	112.12 and 112.50		20
107.50 and 121.40		30	112.50 and 138.99		30
121.40 and 127.92		25	BRIGHTON and PLACERVILLE:		
127.92 and 127.95		15	94.67 and 94.74		15
127.95 and 132.20		25	94.74 and 111.05		25
132.30 and 139.70		15	111.05 and 111.34		15
139.70 and 142.84		25	111.34 and 139.00		20
			139.00 and 139.30		15
LODI and WOODBRIDGE:		20	139.30 and 149.07		20
			149.07 and 150.01		10

SPEED RESTRICTIONS FOR TRAINS—Continued

EASTWARD			PSGR TRAINS	FRT	WESTWARD			PSGR TRAINS	FRT
MP	MP	Column:	1	2	MP	MP	Column:	1	2
LATHROP to FRESNO:					FRESNO to LATHROP:				
On East leg of wye, Lathrop			25	25	205.50 to 199.28			35	35
92.80 to 93.07 (switches)			20	20	199.28 to 184.50			70	55
93.07 to 94.00			30	30	184.50 to 182.60			45	45
94.00 to 107.50			70	55	182.60 to 151.60			70	55
107.50 to 114.00			45	45	151.60 to 149.70			45	45
114.00 to 126.00			70	55	149.70 to 126.30			70	55
126.00 to 126.30			65	55	126.30 to 126.00			65	55
126.30 to 149.70			70	55	126.00 to 114.00			70	55
149.70 to 151.60			45	45	114.00 to 107.50			45	45
151.60 to 182.60			70	55	107.50 to 94.00			70	55
182.60 to 184.50			45	45	94.00 to 93.07			30	30
184.50 to 199.28			70	55	(switches)			20	20
199.28 to 201.89			35	35	East leg of wye, Lathrop			25	25
201.89 to 201.93 (thru turnout)			25	25					
201.93 to 205.50			35	35					
BIOLA JCT. and BIOLA:									
208.62 and 199.93			40	40					

EASTWARD			PSGR TRAINS	FRT	WESTWARD			PSGR TRAINS	FRT
MP	MP	Column:	1	2	MP	MP	Column:	1	2
TRACY to FRESNO:					FRESNO to TRACY:				
82.58 to 83.00 (Jct. Switch)			15	15	207.36 to 206.87 (Jct. Switch)			15	15
83.00 to 140.10			40	40	206.87 to 141.30			40	40
140.10 to 141.30			35	35	141.30 to 140.10			35	35
141.30 to 206.87			40	40	140.10 to 83.00			40	40
206.87 to 207.36 (Jct. Switch)			15	15	83.00 to 82.58 (Jct. Niles Lines)			15	15
INGLE and RIVERDALE:									
181.97 and 215.00				20					

Trains handling tank cars containing Flammable Compressed Gas must not exceed 55 MPH. Where maximum authorized speed is less than 55 MPH and more than 25 MPH, train must be operated at 5 MPH less than the maximum authorized speed and must not exceed 30 MPH at the following locations:

Polk-Elvas	MP 132.0 to MP 136.0
Stockton	MP 87.5 to MP 90.4
Modesto	MP 110.0 to MP 114.0
Turlock	MP 125.0 to MP 127.0
Merced	MP 149.0 to MP 151.0
Madera	MP 183.0 to MP 185.0
Fresno	MP 199.0 to MP 209.0
Patterson	MP 106.5 to MP 108.0
Newman	MP 119.0 to MP 120.0
Gustine	MP 123.0 to MP 124.0
Los Banos	MP 140.1 to MP 141.3
Firebaugh	MP 165.5 to MP 167.0
Mendota	MP 174.0 to MP 175.5

Maximum authorized speed for freight trains is 55 MPH.

EXCEPT:

LABRF, LABRT, BRLAT, and BKRVP may be authorized by train order to operate at Column 1 speeds not exceeding 65 MPH between Tracy and Polk; and between Lathrop and Fresno, provided train contains no restricted cars or empties except cabooses and does not exceed 80 tons per operative brake and/or 120 cars.

Stockton: Coupled-in-motion track scale located on lead track, Stockton Yard, MP 89.2. Speed of train when weighing must not exceed 4 MPH. Bi-directional indicator lights located at scale, MP 88.5 and MP 89.8. Continuous white aspect indicates speed is under 4 MPH, flashing white aspect, speed is in excess of 4 MPH. Speed of train when weighing should be at continuous speed without slack action or stopping.

Tracy: Westward freight trains passing signal 735, eastward trains passing yard office, and trains to or from the West Side Line operating on either leg of wye, must not exceed 10 MPH to allow visual verification of consist.

SPEED RESTRICTIONS FOR OTHER THAN MAIN TRACKS	With Caution Not Exceeding MPH
Through sidings, yard and other tracks, wyes, crossovers and turnouts.....	10
Except:	
Through controlled sidings and turnouts in CTC.....	25
Tracy Freight Lead, from Banta Rd., MP 73.6, to MP 75.9.....	30
Except:	
Through spring switch at east end.....	25
Madera: Winery Spur.....	25
Biola Jct.: Freight Lead.....	30

SPECIAL INSTRUCTIONS—EAST VALLEY SUBDIVISION

RULE P. LOCATION OF OVERHEAD AND SIDE STRUCTURES NOT STANDARD CLEARANCE ON MAIN TRACK AND SIDINGS

MP	Location	Description
210.82	Tehama	Sacramento River Bridge Overhead

RULE 7-C. Roseville: Switchmen must use yellow flag by day and yellow light by night or oral authorization in giving proceed signals for movement of trains.

RULE 10-J. Speed signs placed to left of track:
Westward at MP 145.88 reading 45.

RULE 83-A. At the following stations, only the trains indicated will register:

Roseville—All trains except extra trains consisting entirely of passenger equipment and not terminating at Roseville.

RULE 93. Yard limits are established at the following locations:

West MP	East MP
98.04	Roseville (Eastward and No. 2 Track).....110.87
98.04	Roseville (No. 1 and Westward Track).....110.87
143.78	Berg (Yuba City Branch).....147.93
146.59	Oroville.....End of Branch
183.48	Chico (Stirling City Branch).....189.00

Roseville: Westward trains and engines from East Valley Subdivision must not pass Signal 1063 unless proceed signal, yellow flag by day, yellow light by night, or oral authorization received from switchman. When Signal 1063 displays proceed indication, switch point indicator located adjacent to Signal 1063 will be dark. Westward trains and engines entering the yard must not pass red aspect of switch point indicator adjacent to Signal 1063 until switchman or yardmaster notified and position of switches are rechecked for proper position and authority received from switchman to proceed.

For other train and engine movements Roseville Yard, see Roseville Subdivision Rule 93.

RULE 98. Railroad crossings at grade not interlocked:

Roseville: Lead from yard to East Valley Subdivision main track crosses No. 2 Track and No. 1 Track of Roseville Subdivision near passenger station. Eastward freight trains from yard to East Valley Subdivision will be governed by Signal 1062 and westward freight trains from East Valley Subdivision to enter yard will be governed by bottom unit of Signal 1063 before fouling or moving over No. 2 Track and No. 1 Track.

Yuba City: SNRy at Bridge St., and at B St.—Stop within 200 feet of crossings.

MP 186.60 on Stirling City Branch: SNRy crossing—Stop within 200 feet of crossing.

Stop signs with red reflective background have been placed at the following railroad grade crossings:

Yuba City.....	{ Bridge Street. B Street.
Sterling City.....	MP 186.60

RULE 103. Trains and engines must stop and be preceded by flagman before crossing highways and streets at:

Clayton Spur.

Chico: When westward absolute signal at east end of siding displays stop indication, trains must stop east of 8th St. crossing to avoid blocking fire route.

RULE 104. The normal position of rigid switches at junctions:

Chico.....	Stirling City Branch, for Stirling City Branch.
Berg.....	Yuba City Branch Junction Switch, for controlled siding.

RULE 204. Trains to or from East Valley Subdivision with the same conductor and engineer operating through Tehama may be issued train orders on East Valley Subdivision or West Valley Subdivision that affect their movement on either of these subdivisions.

RULES 283 and 288. Berg: Coupled-in-motion track scale at MP 145.47. Westward trains entering siding at Berg may receive an "SC" illuminated letter light, indicating train is to be weighed. Train to be moved through siding to east switch of scale track and lined through scale track. Speed of train when weighing must not exceed 4 MPH. A white speed indicator light located west of scale house is bi-directional, displaying indication both eastward and westward. Light is so set as to give a continuous white aspect for speeds under 4 MPH and will give a flashing white aspect for speeds in excess of 4 MPH. Movement of train over scale should be at a continuous speed of 4 MPH without slack action or stopping.

Reverse movement must not be made over scale while scale is activated. Bi-directional white speed indicator light is illuminated when scale is activated and if necessary to deactivate scale so reverse movement can be made contact CTC dispatcher at Roseville.

RULE 306. The following home signals, equipped with triangular plate displaying the letter "P," have included in their control limits some special protective device. Absolute signals are listed as "P-A."

Eastward	Protection	Westward
P-A	Collision detector, highway underpass, MP 108.22.....	P-1099
P-A	High water detector, bridge No. 135.00.....	P-1357
P-A	Spring switch west end siding Marysville.....	P-A
	Spring switch Yuba City Branch Jct. Switch.....	P-A
P-1906	High water detector, bridge No. 191.83.....	P-A

SPRING SWITCHES

RULE 538. Spring switches equipped with facing point locks are located as follows:

Station	Location	Normal Position
Marysville.....	West end yard.....	Main Track

Spring switches not equipped with facing point locks are located as follows:

Station	Location	Normal Position
Stirling City.....	50 feet west of balloon track switchFor eastward movement	

Main track switch 50 feet east of spring derail at Stirling City must be left lined and locked for movement into balloon track.

LETTER-TYPE INDICATORS

RULE 705. Indicators located as follows:

Illum. On	Letter Signal	Approaching	Authorizes and requires movement as follows:
S.....	P-A.....	Marysville.....	Enter yard (West switch Marysville)
S.....	A.....	Signal west end Berg siding.....	Enter Yuba City Branch

SPECIAL INSTRUCTIONS—EAST VALLEY SUBDIVISION

CENTRALIZED TRAFFIC CONTROL

RULE 760. Limits extend from eastward absolute signal, MP 106.65 Roseville to westward absolute signal at end of double track Tehama, MP 211.88.

To enter East Valley main track from east leg of wye, Roseville, at hand operated switch, permission for the movement must first be obtained from the train dispatcher, then line switch and be governed by indication of Signal 1068 and instructions from train dispatcher.

Binney Jct.: Movements across WP, at MP 141.8 are under control of SP train dispatcher. When absolute signals governing movements over crossing display "Stop" indication, member of crew must contact train dispatcher for instructions. If signal cannot be cleared, after ascertaining from indications on control machine that there is no train approaching from either direction on WP, train dispatcher may authorize member of crew to operate "Push Button Time-Release" in accordance with instructions posted in box marked "SP" near crossing.

Marysville: Eastward absolute signal located on signal bridge at east end of yard governs movement from yard as follows:

- Top Unit To end CTC
- Middle Unit Thru Cross-Over to main track
- Bottom Unit Thru Cross-Over to west leg of Wye and Oroville Branch

Operating instructions for push button time release:

Press button until amber light is illuminated, then release.

After time release interval red light should be illuminated, indicating time release has functioned and intersecting route is clear of conflicting train movements.

If absolute signal does not then indicate proceed after time release actuated but red light is illuminated in push button box, train may proceed over intersecting railroad crossing under provisions of Rule 776 without providing flag protection on intersecting route.

If absolute signal does not display proceed indication and red light is not illuminated in push button box after time release actuated, train may proceed only as provided by Rule 663(c) and Rule 776.

Time release intervals:

Binney Junction—5 minutes, 8 seconds.

GENERAL REGULATIONS

RULE 827. DRAGGING AND/OR DERAILED EQUIPMENT DETECTOR AND INDICATOR INSTALLED AT THE FOLLOWING LOCATIONS:

MP	Location(s)
108.2	Roseville and Sunset-Whitney Ranch
149	At Berg
163.9	Riceton
187.7	Chico-Nord

HOT BOX DETECTORS

Illum.	On Signal	Approaching	Location of Readout
H	Westward Absolute Signal E.E.	Ostrom	Westward Absolute Signal W.E. Ostrom
W	1356	Rupert Dantoni Jct.	
W	1377	Ostrom	
H	MP 138.03	Dantoni Jct.	MP 139.8 Dantoni Jct.
W	2044	Los Molinos	
H	2045	Vina	Westward Absolute Signal W.E. Vina
W	2071	Vina	
H	MP 208.0	Los Molinos	MP 209.8 Los Molinos

When letter "W" is illuminated, train must stop, member of train crew must contact train dispatcher before proceeding and be governed by his instructions.

SCANNER SITES

MP	Type	Direction(s)	Location
115.4	D	West	Lincoln
136.4	A	Both	Ostrom-Rupert
163.9	C	Both	Riceton
206.3	A	Both	Vina-Los Molinos

Refer to Rule 827, All Subdivisions.

RULE 827-A. Trains handling tank cars containing Flammable Compressed Gas must stop and inspect train at the following location(s):

Eastward Trains	Westward Trains
Chico

Refer to Rule 827-A, All Subdivisions.

RULE 872. Enginemen taking charge of road engines at Roseville diesel facility will consider engines as having been amply supplied with water, fuel, sand and other supplies.

AIR BRAKE RULES

FREIGHT AND MIXED TRAINS

RULE 2, A. Taking Charge of Engines.

Will apply at:
Roseville.

RULE 17. Retaining valves must be used on descending grades as follows:

Stirling City to Butte Creek:

WITHOUT DYNAMIC BRAKE IN OPERATION:
One retaining valve for each 80 tons in train and speed must not exceed 15 MPH.

WITH DYNAMIC BRAKE IN OPERATION:

Permissible Tons Per Unit Without Retaining Valves	Basic-Dynamic Brake					Extended Range Dynamic Brake		
	4 Axle		6 Axle		4 Axle		6 Axle	8 Axle
With dynamic brake in operation but without pressure maintaining system of braking	325	475	350	550	725			
With dynamic brake in operation and with pressure maintaining system of braking	700	1050	800	1200	1600			

With dynamic brake in operation but **without** pressure maintaining system of braking 325 475 350 550 725

With dynamic brake in operation and **with** pressure maintaining system of braking 700 1050 800 1200 1600

If permissible tonnage is exceeded one retaining valve must be used for each 150 tons in excess thereof.

Refer to Air Brake Rule 17, All Subdivisions.

RULE 24. Will apply at Roseville.

RULE 24-E. Will apply to trains arriving Roseville.

RULE 25. Will apply to westward trains at Stirling City.

RULE 33. Stirling City to Butte Creek: Maximum tons per operative brake—80 tons.

Restrictive grades are as follows:

	MP	to	MP	MPH
Westward	215.46	188.75 15

MISCELLANEOUS

1. Crossover diverging at MP 141.90 to WP at WP MP 180.42.

Hand operated switch installed at west end crossover is normally positioned for spur located at MP 141.83. Hand operated switch at east end crossover, normally positioned for WP main track, is equipped with electric lock and protected by separate hand operated derail located approximately 110 feet west of WP main track.

Instructions for operation of electric lock are located in phone box adjacent to WP main track switch. Electric lock switch must be operated before derail is lined, otherwise electric lock will not release. **WP operating Rule 550 applies.**

Eastward SP trains and engines must contact WP train dispatcher to obtain permission to operate electric lock and instructions to move Marysville to Oroville.

Westward SP trains and engines must contact WP train dispatcher for instructions to move Oroville to Marysville.

These movements governed by WP Rules, Timetable, Bulletins and Special Instructions.

SNRY trains will operate on SP tracks between MP 152.20, Live Oak, and MP 178.2, Durham, **being governed by SP Rules, Timetables, Special Instructions and timetable bulletins.**

Hand operated switch equipped with electric lock located at SN track connection to SP main track at MP 152.20, Live Oak. Eastward SN trains and engines must contact SP train dispatcher for permission to operate electric lock. Instructions for operation of electric lock are located in phone box adjacent to switch. SN trains will be governed by signal 1522.

Hand operated switch equipped with electric lock located at SN track connection to SP main track at MP 178.2, Durham. Westward SN trains and engines must contact SP train dispatcher for permission to operate electric lock. Sign reading "DO NOT FOUL MAIN TRACK WITHOUT DISPATCHER'S PERMISSION" is located on SN connection to SP main track.

2. Engines listed must not operate on tracks shown below:

Class of Engine	Restricted Tracks
All engines Chico—Diamond International Co. track off east leg of wye.

3. LOAD LIMIT (car and contents):

*Roseville-Tehama 315,000 pounds
Chico-Stirling City 240,000 pounds
Berg-Tudor 240,000 pounds
*Binney Jct.-Oroville (WPRR) 263,000 pounds

*Refer to All Subdivisions, Page 21 Miscellaneous Item 14.

Unless authorized by Superintendent, heavier loads must not be handled.

SPEED RESTRICTIONS FOR TRAINS: Maximum speed of trains in territory shown below is subject to further restrictions applicable to engines in the train as shown in **SPEED RESTRICTIONS FOR ENGINES** appearing on page 19 and **MAXIMUM SPEED PERMITTED WITH CERTAIN EQUIPMENT and OTHER MAXIMUM SPEEDS** appearing on page 21 of Timetable for All Subdivisions. Speed must be further reduced as prescribed by speed signs, except as specifically authorized by Special Instructions herein, or by timetable bulletin.

BETWEEN MP MP Column:	PSGR TRAINS	FRT
	1	2
ROSEVILLE and TEHAMA:		
106.61 (106.57)		
and 106.85	15	15
106.85 and 116.60	65	55
116.60 and 117.05	55	55
117.05 and 130.46	50	40
130.46 and 134.42	65	55
134.42 and 139.80	55	55
139.80 and 141.95	25	25
141.95 and 143.88	45	45
143.88 and 183.80	70	55
183.80 and 184.50	25	25
184.50 and 209.93	70	55
209.93 and 211.40	35	35
211.40 and 211.82 (jet. switch)	25	25
CHICO and STIRLING CITY:		
184.38 and 185.38		15
185.38 and 188.75		20
188.75 and 215.46		15
BERG and END OF BRANCH:		
144.43 and 148.24		15

Trains handling tank cars containing Flammable Compressed Gas must not exceed 55 miles per hour. Where maximum authorized speed is less than 55 MPH and more than 25 MPH, train must be operated at 5 MPH less than maximum authorized speed and must not exceed 30 MPH at the following locations:

Lincoln	MP 116.6 to MP 117.5
Wheatland	MP 127.8 to MP 128.3
Live Oak	MP 151.4 to MP 151.8
Gridley	MP 157.5 to MP 158.2
Biggs	MP 161.2 to MP 161.5

Maximum authorized speed for freight trains is 55 MPH, except BRLAT, LABRF and LABRT may operate at Column 1 speeds not exceeding 65 MPH when authorized by train order, provided train contains no restricted cars, or empties except cabooses and does not exceed 80 tons per operative brake and/or 120 cars.

SPEED RESTRICTIONS FOR OTHER THAN MAIN TRACKS	With Caution Not Exceeding MPH
Through sidings, yard and other tracks, wyes, balloon tracks, crossovers and turnouts	10
Except:	
Through sidings and turnouts at Sunset-Whitney Ranch, Brock, Ostrom, Berg, Fagan, Richvale, Chico, Anita and Vina	25

SPECIAL INSTRUCTIONS—WEST VALLEY SUBDIVISION

RULE P. LOCATION OF OVERHEAD AND SIDE STRUCTURES NOT STANDARD CLEARANCE ON MAIN TRACK AND SIDINGS

MP	Location	Description
89.26	Yolo	Cache Creek bridge...Overhead
167.72	West of Hamilton	Stony Creek bridge...Side
300.00	Lamoine	Bridge on siding...Side
301.80	Lamoine	Bridge No. 6. Overhead and side
302.20	Lamoine	Bridge No. 7. Overhead and side
305.40	Gibson	Tunnel No. 13. Overhead and side
306.70	Fisher	Bridge No. 9. Overhead and side
310.60	Sims	Bridge No. 13. Overhead and side

RULE 6-A. Davis: North siding is first track west of main track on Gerber line extending from MP 76.03 to MP 76.75.

Wyo: Siding is second track of the two tracks paralleling main track.

Redding: Siding is first track on south side of main track extending from MP 258.68 to MP, 256.58. This is not a controlled siding and all movements must be made with caution.

RULE 21. Identification of superior trains via Corning may be made at Redding or between Redding and Tehama and such identification will apply at Tehama.

RULE 82-A. Westward regular trains via Corning must be authorized at Redding by clearance bearing the OK, time and initials of the Chief Train Dispatcher and specifying green or no signals as required.

RULE 83-A. At the following stations, only the trains indicated will register:

- Woodland—Trains originating or terminating.
- Harrington—Trains specified by train order and trains to and from Colusa Br.
- Orland—Trains originating or terminating.
- Wyo—Trains specified by train order and trains to and from Hamilton Br.
- Red Bluff—Trains originating or terminating.
- Redding—Regular trains via Corning and trains to and from the Matheson Branch.

RULE 83-B. At open train-order offices, trains may register by ticket as follows:

- Davis—All trains to or from West Valley Subdivision.
- Redding—Regular trains via Corning.

RULE 85. A section must not pass and run ahead of another section of the same schedule in CTC limits or on double track between Redding and Tehama without first exchanging train orders with section to be passed, each section to display signals if necessary.

RULE 93. Yard limits are established at the following locations:

West MP		East MP
74.20	Davis (Dixon line)	77.37
	Davis (Tehama line)	78.00
83.66	Woodland	85.82
	Woodland (Knights Landing Branch, end of Branch)	88.24
147.96	Willows	150.84
164.48	Orland	167.72
177.62	Wyo (Colusa Branch)	
120.00	Grimes	122.00
169.00	Hamilton	171.00
	Redding (Matheson Branch)	259.23

RULE 97. Extra trains must not operate via Colusa Branch unless authorized by train order.

RULE D-97. Applies on both main tracks between CTC limit Gerber and CTC limit Tehama.

RULE 99-C. Will apply on Colusa Branch.

RULE 103. Trains and engines must stop and be preceded by flagman before crossing highway at:

- Woodland... Main St. crossing on house Track No. 3628.
- Orland... Spur Track No. 3339, serving Murco Produce crossing Tehama Street.

Woodland: STOP signs installed on Ogden Lead Track No. 3638 at Cross Street and on Ogden Lead Track No. 3636 and House Track No. 3628 at Oak Street. Warning by crew member to traffic must be afforded before moving over these crossings.

Passenger trains stopping at Redding station will stop clear of impulse circuit indicated by white marker on platform, to permit crossing gates to raise. When train starts, proceed slowly to permit gates to lower after passing impulse circuits. Sound detector microphones adjacent to track just east of Yuba St. for westward movement and just west of Tehama St. for eastward movement. Trains stopped to receive or discharge traffic must sound whistle to activate gates and crossing must not be entered until gates are down.

Girvan: Whistle mikes installed on main track and siding east of road crossing at MP 253.3 at west end.

Westward trains stopped east of the crossing, MP 253.3, on main track or siding will permit gates to raise and must sound whistle to reactivate gates and crossing must not be entered until gates are down.

RULE 104. The normal position of rigid switches at junctions:

- Woodland... Knights Landing Branch, for movement from siding to Knights Landing Branch,
- Harrington... Colusa Branch, for siding,
- Wyo... Colusa Branch, for siding,
- Redding... Matheson Branch, for Silverthorn line.

RULE 204. Trains to or from East Valley Subdivision with the same conductor and engineer operating through Tehama may be issued train orders on East Valley Subdivision or West Valley Subdivision that affect their movement on either of these subdivisions.

Rule 221. Red Bluff: is a train order office for trains originating only.

Redding: is a train order office for trains originating and westward trains via Corning only.

RULE S-240. MOVEMENT OF TRAINS BY STAFF SYSTEM.

Applies at following location(s):

Territory	Register Location
Colusa Branch:	
Harrington-End of Branch	Harrington
Hamilton Branch:	
Wyo-End of Branch	Wyo
Matheson Branch:	
Redding-Matheson	Redding

RULE D-251. Applies between MP 211.88 Tehama, and MP 214.9 Gerber, on eastward and westward main tracks.

RULE 291. Dunsmuir Yard: Unit for display of flashing yellow installed on mast of westward absolute signals at west end main track and siding, MP 319.61.

RULE 306. The following home signals, equipped with triangular plate displaying the letter "P," have included in their control limits some special protective device.

Eastward	Protection	Westward
P-846	Collision barricade detector, MP 85.30	P-855
P-846	Collision barricade detector, MP 85.40	P-855
P-898	Collision barricade detector, MP 89.70	P-903
P-886	Collision barricade detector, MP 88.70	P-897
P-1182	High water detector, bridge 118.88	P-1197
P-1368	High water detector, bridge 137.10	P-1381
P-1748	High water detector, bridge 176.21	P-1769
P-A	Spring switch west end siding Redding	
P-2388	High water detector, Bridge 239.88	P-2403
P-2720	Fire detector, Pit River Bridge, and Slide detector fences, MP 273.70 and 274.10	P-2743
P-2882	Fire detector, bridge 288.50, and Slide detector fences, MP 295.7 and 296.0	P-A
P-A	Slide detector fences, MP 300.84 and 301.3	P-3015
P-3024	Slide detector fence, MP 302.70	P-A
P-3050	Slide detector fence, MP 305.60	P-3061
P-3062	Slide detector fence, MP 306.9	P-3073
P-A	Slide detector fence, MP 310.4	P-3111

AUTOMATIC BLOCK SIGNAL SYSTEM

RULE 505. Davis: Eastward trains originating at Davis via Tehama, are authorized to operate ahead of No. 14, from eastward "SA" signal at MP 75.7 which governs movement on Tehama Line to east switch of north siding, being governed by signal indication or Rule 663.

SPRING SWITCHES

RULE 538. Spring switches equipped with facing point locks are located as follows:

Station	Location	Normal Position
Redding	West end siding	Main track

INTERLOCKING

RULE 606. Davis: Limits extend on eastward and westward main tracks from interlocking signals at MP 75.25 to interlocking signal on signal bridge at MP 75.98 on westward main track, interlocking signals 325 feet west of MP 75.98 on eastward main track and eastward siding, interlocking signal at MP 75.97 on the westward siding and to westward interlocking signal at MP 75.80 on the Gerber line.

Switch machine cranks for hand operating dual control switches are mounted on signal instrument case on south side of track at west end of street underpass on the west end; on instrument case on south side of track opposite P.G.&E. switch on the Sacramento end; and on instrument case between 3rd Street and 4th Street on the Woodland end.

When necessary to hand operate dual control switches, permission must be obtained from the operator.

Instructions for hand operating dual control switches are mounted on cases above switch machine crank holders.

LETTER-TYPE INDICATORS

RULE 705. Indicators located as follows:

Illum. Letter	On Signal	Approaching	Authorizes and requires movement as follows:
M	767	Davis (Tehama Line)	Proceed on main track to interlocking signal at MP 75.80 being governed by signal indication.
S	P-A	Redding, west switch	Enter siding
W	MP 319.9	South 1st St. Crossing, Dunsmuir Yard	West trains on main track or sidings when indication illuminated must stop short of 1st St. crossing and wait until illumination is extinguished.

CENTRALIZED TRAFFIC CONTROL

RULE 760. Limits extend from eastward absolute signal at east end double track, Gerber, to east switch, Dunsmuir.

Tehama: Eastward "SA" signal at west switch of west crossover Tehama on West Valley route governs movement through crossover to eastward main track; eastward "SA" signal west of Tehama crossovers on East Valley route governs movement to eastward main track.

Westward "SA" signal at west end double track on westward main track governs movement as follows:

- Top unit To West Valley route.
- Bottom unit To East Valley route.

Westward dwarf "SA" signal at west end double track on eastward main track governs movement to either West or East Valley route.

Redding: Dwarf type indicator for display of flashing white light located on siding west side of south street. Eastward trains using siding must not pass dwarf type indicator until flashing white light displayed, which will authorize train to proceed on siding to absolute signal.

Indicator for display of illuminated "Wait" located on east end of main track signal 2582 at east switch No. 1 track. When illuminated, requires eastward trains to wait west of South Street.

When held by these indicators, member of train crew must contact train dispatcher by phone and be governed by his instructions.

Lakehead: Absolute signal at the east end of siding governs movement as follows:

- Top Unit On main track,
- Middle Unit To siding,
- Bottom Unit To house track.

Telephone for communicating with train dispatcher located at:
Signals 2596, 2597, 2721, 2828, 2829, 2837, 2838, 2868, 2869, 2882 and 2883.

GENERAL REGULATIONS

RULE 825. Instructions for setting hand brakes:

Dunsmuir and Dunsmuir Yard:

- Passenger trains { Two brakes on east end, Three brakes on west end.
- Freight trains or cuts of 25 cars or less Ten brakes on west end.
- Freight trains or cuts of 26 to 50 cars { Ten brakes on west end, Five brakes on east end.
- Freight trains or cuts of over 50 cars { Ten brakes on west end, Ten brakes on east end.

Employee releasing any of these brakes must apply an equal number to replace them, except when preparing train for departure.

Dunsmuir Yard: Hand brakes will not be applied on freight trains if outgoing crew takes charge of train on arrival unless engine is detached.

Dunsmuir: Hand brakes will not be applied on passenger trains standing at the station unless engine is detached, provided conductor has reached understanding that engineer will remain on engine at all times and control train by use of air brakes.

Portable rail skids are hung on posts at lower end of sidings at:

- Central Valley, Gray Rocks, Lakehead, Delta, Lamoine, Gibson, Sims, Conant, Castle Crag and Given Spur, MP 256.1.
- When necessary to leave cars on these tracks except Given Spur, permission must first be obtained from train dispatcher.
- Refer to Rule 825, All Subdivisions.

SPECIAL INSTRUCTIONS—WEST VALLEY SUBDIVISION

RULE 827. DRAGGING AND /OR DERAILED EQUIPMENT DETECTOR AND INDICATOR INSTALLED AT THE FOLLOWING LOCATIONS:

MP	LOCATION
225.7	Red Bluff-Blunt.
251.37	Anderson-Girvan.
267.5	Central Valley-Gray Rocks.
279.2	Obrien-Mead.
305.5	East Portal, Tunnel No. 13 between Sims-Gibson.

HOT BOX DETECTORS

Illum. Letter	On Signal	Approaching	Location of Readout
H	2387	Draper	Westward Absolute Signal W.E. Draper
W	2388	Culp	
W	2403	Draper	
H	2418	Culp	Eastward Absolute Signal E.E. Culp

When letter "W" is illuminated, train must stop. Member of train crew must contact train dispatcher before proceeding and be governed by his instructions.

SCANNER SITES:

MP	Type	Direction(s)	Location
92.6	C	Both	At Dufour
120.6	C	Both	At Williams
154.2	C	Both	At Artois
179.7	C	Both	At Corning
240.0	A	Both	Draper-Culp
267.5	C	Both	Central Valley-Gray Rocks
283.2	C	Both	At Lakehead

Refer to Rule 827, All Subdivisions.

RULE 827-A. Trains handling tank cars containing Flammable Compressed Gas must stop and inspect train at the following location(s):

Eastward Trains	Westward Trains
Rawson	Yolo, West end.

Refer to Rule 827-A, All Subdivisions.

AIR BRAKE RULES

FREIGHT AND MIXED TRAINS

RULE 17. Retaining valves must be used on descending grades as follows:

Dunsmuir Yard and Delta, Middle Creek and Matheson.

WITHOUT DYNAMIC BRAKE IN OPERATION:

One retaining valve for each 80 tons in train. If gross tonnage exceeds 80 tons per operative brake, retaining valves must be used on all cars and speed must not exceed 15 MPH.

WITH DYNAMIC BRAKE IN OPERATION:

Permissible Tons Per Unit Without Retaining Valves

	Basic Dynamic Brake		Extended Range Dynamic Brake		
	4 Axle	6 Axle	4 Axle	6 Axle	8 Axle
	With dynamic brake in operation but without pressure maintaining system of braking:				
Dunsmuir Yard and Delta	1050	1550	1300	1950	2600
Middle Creek and Matheson	525	775	650	950	1250
With dynamic brake in operation and with pressure maintaining system of braking:					
Dunsmuir Yard and Delta	1900	2850	2325	3500	4650
Middle Creek and Matheson	1500	2250	1800	2700	3600

If permissible tonnage is exceeded, one retaining valve must be used for each 150 tons in excess thereof.

Refer to Air Brake Rule 17, All Subdivisions.

RULE 24-G. Will apply at Dunsmuir Yard and Dunsmuir.

RULE 33. Middle Creek and Matheson: Maximum tonnage per operative brake—80 tons; except with dynamic brake and pressure maintaining system of braking in operation; with not more than 20 cars for each six axles of dynamic brake; with speed not exceeding 20 MPH, and with all retaining valves on loaded cars in high pressure position—100 tons.

Should dynamic brake failure occur while handling in excess of 80 tons per operative brake, train may proceed at speed not exceeding 15 MPH, if in judgment of conductor and engineer it is safe to do so, and provided retaining valves are used as prescribed by Air Brake Rule 17.

Restrictive grades are as follows:

Westward	MP	to	MP	MPH
Between Sims and Gibson	307.6		306.3	25

MATHESON BRANCH

Westward	263.0	260.6	20
Eastward	264.1	265.0	20

MISCELLANEOUS

1. Eighty-five-foot tri-level flat cars, loaded or empty, must not be handled on Matheson Branch.

2. Gray Rocks: Engines or cars not permitted beyond RESTRICTION sign located at Track Nos. 3013, 3014 and beyond east Switch Track No. 3011.

3. LOAD LIMIT (car and contents):

*Davis-Tehama	315,000 pounds
*Tehama-Dunsmuir	315,000 pounds
Woodland-Sugarfield	240,000 pounds
Harrington-End of Colusa Branch	240,000 pounds
Hamilton-End of Branch	240,000 pounds
Redding-Matheson	251,000 pounds
Except gondola cars, series SP 345000-345699	240,000 pounds

*Refer to All Subdivisions, Page 21, Miscellaneous item 14.

Unless authorized by Superintendent, heavier loads must not be handled.

SPECIAL INSTRUCTIONS—WEST VALLEY SUBDIVISION

SPEED RESTRICTIONS FOR TRAINS: Maximum speed of trains in territory shown below is subject to further restrictions applicable to engines in the train as shown in **SPEED RESTRICTIONS FOR ENGINES** appearing on pages 19 and **MAXIMUM SPEED PERMITTED WITH CERTAIN EQUIPMENT** and **OTHER MAXIMUM SPEEDS** appearing on page 21 of Timetable for All Subdivisions. Speed must be further reduced as prescribed by speed signs, except as specifically authorized by Special Instructions herein, or by timetable bulletin.

Trains handling tank cars containing Flammable Compressed Gas must not exceed 55 miles per hour. Where maximum authorized speed is less than 55 MPH and more than 25 MPH, train must be operated at 5 MPH less than maximum authorized speed and must not exceed 30 MPH at the following locations:

Woodland	MP 84.4 to MP 85.5
Arbuckle	MP 113.1 to MP 113.5
Williams	MP 124.0 to MP 124.3
Willows	MP 149.4 to MP 150.2
Orland	MP 165.3 to MP 165.7
Corning	MP 178.0 to MP 178.9
Red Bluff	MP 223.2 to MP 223.6
Anderson-Redding	MP 246.8 to MP 258.8

Trains with AMTRAK EP630A engines in consist, unless otherwise restricted to a lower speed, must not exceed 50 MPH from point where engine enters curve until engine and first car behind engine are again on tangent track between the following mile post locations:

MP 81.9-MP 82.3	MP 231.9-MP 232.1
MP 85.6-MP 86.1	MP 242.5-MP 242.8
MP 226.2-MP 226.5	MP 260.0-MP 261.1
MP 227.8-MP 228.1	MP 262.1-MP 263.3
MP 230.7-MP 230.9	MP 264.8-MP 268.2

At Woodland, Willows, Orland, Corning and Anderson when engine passes last crossing within limits of restriction in direction of movement, speed may be resumed to that shown on next speed sign.

Between Davis and Tehama, Column 1 speeds will apply only to trains consisting entirely of passenger equipment.

Maximum authorized speed for freight trains is 55 MPH, except between MP 214.90 and MP 321.00 freight trains may operate at column 1 speeds not exceeding 65 MPH when authorized by train order, provided train contains no restricted cars, or empties except cabooses and does not exceed 80 tons per operative brake and/or 120 cars.

Following classes of engines must not exceed the speed shown when operating between MP 108.81 and MP 170.12 on the Colusa Branch:

ES410 and AS410	30 MPH
-----------------	--------

EASTWARD			PSGR TRAINS	FRT	WESTWARD			PSGR TRAINS	FRT
MP	MP	Column:	1	2	MP	MP	Column:	1	2
DAVIS to DUNSMUIR:					DUNSMUIR to DAVIS:				
75.60 to 76.00			40	40	322.57 to 295.60				
76.00 to 84.40			60	40	(288.66)			25	25
84.40 to 85.50			40	40	288.66 to 285.93			40	40
85.50 to 91.00			60	40	285.93 to 269.05			45	45
91.00 to 103.00			70	55	269.05 to 261.17			65	55
103.00 to 112.00			60	40	261.17 to 259.66			60	55
112.00 to 128.00			70	55	259.66 to 258.00			45	45
128.00 to 149.50			60	40	258.00 to 247.27			70	55
149.50 to 150.00			40	40	247.27 to 247.02			60	55
150.00 to 178.00			60	40	247.02 to 243.74			70	55
178.00 to 178.90			40	40	243.74 to 242.46			65	55
178.90 to 185.90			70	55	242.46 to 233.60			70	55
185.90 to 186.29					233.60 to 226.61			65	55
(Beginning of D.T.)			35	35	226.61 to 224.39			60	55
186.29 to 213.80			25	25	224.39 to 223.18			45	45
213.80 to 223.18			70	55	223.18 to 214.90			70	55
223.18 to 224.39			45	45	214.90 to 186.29			25	25
224.39 to 226.61			60	55	186.29 to 185.90			35	35
226.61 to 233.60			65	55	185.90 to 178.90			70	55
233.60 to 242.46			70	55	178.90 to 178.00			40	40
242.46 to 243.74			65	55	178.00 to 150.00			60	40
243.74 to 247.02			70	55	150.00 to 149.50			40	40
247.02 to 247.27			60	55	149.50 to 128.00			60	40
247.27 to 258.00			70	55	128.00 to 112.00			70	55
258.00 to 259.66			45	45	112.00 to 103.00			60	40
259.66 to 261.17			60	55	103.00 to 91.00			70	55
261.17 to 269.05			65	55	91.00 to 85.50			60	40
269.05 to 285.93			45	45	85.50 to 84.40			40	40
285.93 to 288.66					84.40 to 76.00			60	40
(295.60)			40	40	76.00 to 75.60			40	40
295.60 to 322.57			25	25					

BETWEEN		ALL TRAINS
MP	MP	
HARRINGTON and END OF BRANCH:		
108.81 and 120.70		35
120.70 and 121.30		15
121.30 and 133.50		35
WYO and END OF BRANCH:		
161.70 and 169.98		35
169.98 and 170.00		15
170.00 and 170.50		20
170.50 and 180.24		35
180.24 and 180.46		15
WOODLAND and SUGARFIELD:		
85.56 and 87.70		20
87.70 and 88.24		10
REDDING and MATHESON		20

SPEED RESTRICTIONS FOR OTHER THAN MAIN TRACKS

Through sidings, yard and other tracks, wyes, balloon tracks, crossovers and turnouts, except: 10

SPEED RESTRICTIONS ON SIDINGS (AND TURNOUTS)

Location	With Caution Not Exceeding MPH
Rawson	25
Blunt	25
Culp	25
Draper	25
Girvan	25
Silverthorn	25
Central Valley	25
Gray Rocks	25
O'Brien	25
Mead	25
Lakehead	25
Delta	20
Lamoine	20
Sims	20
Conant	20
Castle Crag	20

THE UNIVERSITY OF CHICAGO

Department of Chemistry
Chicago, Illinois

Received of Mr. J. H. ...
the sum of ...

for the purchase of ...
...

...

...

...

...

...

...

...

...

...

...

...

...

RULE 10-I

Oral authorization and acknowledgments between Foremen and Engineers for trains to pass "Red Conditional Stop" signs must be worded in the following forms:

"SP FOREMAN AT MP CALLING SP (Train No.)"

(After train answers giving his identification):
(i. e.) SP Train

Foreman's Response

"THIS IS SP FOREMAN . . . IN CHARGE OF THE WORK BETWEEN MP . . . AND MP SP TRAIN ORDER NO. . . . WE ARE IN THE CLEAR AND YOU MAY PROCEED PAST THE RED CONDITIONAL STOP SIGN AND THROUGH THE LIMITS OF ORDER AT MPH, REPEAT MPH"*

Engineer's Response

"THIS IS ENGINEER SP TRAIN I MAY PROCEED PAST THE RED CONDITIONAL STOP SIGN AND THROUGH THE LIMITS OF ORDER NO. . . . BETWEEN MP . . . AND MP . . . AT (Speed). REPEAT (Speed) MILES PER HOUR."

Foreman must acknowledge Engineer's response as follows:

"SP TRAIN ORDER NO. . . . , BETWEEN MP . . . AND MP MPH* OK."

*When no speed restriction account above Form "Y" Train Order, tell train engineer "At Maximum Authorized Speed."

Oral authorization and acknowledgments between Foremen and Engineers for trains to pass "Red Conditional Stop" signs in multiple main track territory must be worded in following forms:

Foreman's Response

"THIS IS SP FOREMAN IN CHARGE OF THE WORK BETWEEN MP . . . AND MP SP TRAIN ORDER NO. . . . WE ARE IN THE CLEAR OF TRACK . . . AND YOU MAY PROCEED PAST THE RED CONDITIONAL STOP SIGN ON TRACK . . . AND THROUGH THE LIMITS OF ORDER AT MPH, REPEAT MPH."

Engineer's Response

"THIS IS ENGINEER SP TRAIN I MAY PROCEED PAST THE RED CONDITIONAL STOP SIGN AND THROUGH THE LIMITS OF ORDER NO. . . . ON TRACK . . . BETWEEN MP . . . AND MP AT (Speed). REPEAT (Speed) MILES PER HOUR."

Foreman must acknowledge Engineer's response as follows:

"SP TRAIN ORDER NO. . . . ON TRACK , BETWEEN MP . . . AND MP MPH OK."

SPEED TABLE

TIME PER MILE	MILES PER HOUR
36"	100
37"	97.3
38"	94.7
39"	92.3
40"	90
41"	87.8
42"	85.7
43"	83.7
44"	81.8
45"	80
46"	78.3
47"	76.6
48"	75
49"	73.5
50"	72
51"	70.6
52"	69.2
53"	67.9
54"	66.7
55"	65.5
56"	64.3
57"	63.2
58"	62.1
59"	61
1'00"	60
1'01"	59
1'02"	58.1
1'03"	57.1
1'04"	56.2
1'05"	55.4
1'06"	54.5
1'07"	53.7
1'08"	52.9
1'09"	52.2
1'10"	51.4
1'11"	50.7
1'12"	50
1'13"	49.3
1'14"	48.6
1'15"	48
1'16"	47.4
1'17"	46.8
1'18"	46.2
1'19"	45.6
1'20"	45
1'25"	42.4
1'30"	40
1'35"	37.9
1'40"	36
1'45"	34.3
1'50"	32.7
1'55"	31.3
2'00"	30
2'15"	28.7
2'30"	24
2'45"	21.8
3'00"	20
3'30"	17.1
4'00"	15
5'00"	12
6'00"	10
7'00"	8.6
7'30"	8
8'00"	7.5
10'00"	6