

## Let's Make SAFETY TICK

**T**hrough rules knowledge  
**I**njury free conditions  
**C**ontrol unsafe practices  
**K**eep alert

### TERMINAL SUPERINTENDENTS

E. R. LAW.....Roseville  
 E. A. VOTAW.....Ogden

SR. ASST. TERMINAL SUPERINTENDENT  
 C. R. URBICK.....Roseville

### ASST. TERMINAL SUPERINTENDENTS

G. L. GRACE.....Roseville  
 H. H. LEWIS.....Roseville  
 R. P. LOPEZ.....Roseville  
 L. F. WRIGHT.....Roseville  
 R. S. BUNTING.....Sacramento  
 D. J. KOLIBABA.....Ogden

### TRAINMASTERS

W. HEFFNER.....Roseville  
 M. L. BURKE.....Roseville  
 T. B. BIRD.....Sacramento  
 J. E. CODY.....Sparks  
 W. P. FISHER.....Carlin  
 C. E. ALWARD.....Redding

### ASSISTANT TRAINMASTERS

P. E. BRISTOL.....Roseville  
 R. L. PODAWILTZ.....Roseville  
 J. A. BIANCHINI.....Roseville  
 W. B. ECKARDT.....Carlin  
 V. E. BELL.....Ogden  
 H. C. FOLKS.....Ogden

### ROAD FOREMEN OF ENGINES

J. E. BRUCE.....Dunsmuir  
 K. C. CARSTENSON.....Roseville  
 C. E. NOVAK.....Roseville  
 D. J. KLOCK.....Sparks  
 J. J. PLANK.....Carlin  
 L. C. WRIGHT, JR.....Ogden

### ASSISTANT ROAD FOREMAN OF ENGINES

D. R. CLOW.....Roseville  
 L. L. LEWIS.....Roseville

### CHIEF TRAIN DISPATCHER

C. L. KENNEDY.....Roseville

# SOUTHERN PACIFIC TRANSPORTATION COMPANY



## SACRAMENTO DIVISION TIMETABLE AND SPECIAL INSTRUCTIONS

# 3

EFFECTIVE SUNDAY, SEPTEMBER 15, 1974  
 AT 12:01 A. M.

**PACIFIC STANDARD TIME**

FOR THE GOVERNMENT AND INFORMATION  
 OF EMPLOYEES ONLY

R. L. KING,  
*General Manager.*

W. J. LACY,  
*Assistant General Manager.*

J. J. WILLIS,  
*General Superintendent of Transportation.*

J. W. BREEN,  
*Superintendent of Transportation.*

R. R. ROBINSON,  
*Superintendent.*

L. G. SIMPSON,  
 H. J. KERINS,  
 C. E. DAY,  
*Assistant Superintendents.*

**SACRAMENTO DIVISION TIMETABLE No. 3, SEPTEMBER 15, 1974**

2

**WEST VALLEY SUBDIVISION**

EASTWARD				Mile Post Location	STATIONS SIDING CAPACITIES AND FACILITIES	Station Number	Distance from Dunsmuir	WESTWARD	
FIRST CLASS								FIRST CLASS	
14 Passenger	366 LABRF	376 LABRT	378 OABRT					11 Passenger	377 BROAT
Leave Daily	Leave Daily	Leave Daily	Leave Daily	Arrive Daily	Arrive Daily				
PM 10.15	AM 7.55		AM 12.30	75.6	N-3351 Yd. Lmts. TO-R 4985 <b>DAVIS</b> KIYPQ	23323	214.2	AM 6.10	PM 8.00
10.21	8.00		12.35	80.7	<b>MERRITT</b>	21510	209.1	5.52	7.10
10.25	8.05		12.39	84.9	Yd. Lmts. TO-R 1910 <b>WOODLAND</b> BKPQ	21340	204.9	5.46	7.01
				89.9	<b>YOLO</b>	21330	199.9		
10.35	8.15		12.50	95.8	5235 <b>ZAMORA</b> P	21320	194.0	5.34	6.45
10.46	8.27		1.02	108.3	R 5360 <b>HARRINGTON</b> P	21305	181.5	5.23	6.30
	8.43			124.2	2375 <b>WILLIAMS</b> P	21255	165.6		
11.04	8.48		1.22	129.1	5065 <b>CORTENA</b> P	21248	160.7	5.05	6.04
11.12	8.59		1.33	138.3	5015 <b>DELANAN</b> P	21237	151.5	4.55	5.52
11.22	9.11		1.46	149.9	5495 Yd. Lmts. <b>WILLOWS</b> P	21222	139.9	4.43	5.40
s 11.37	9.26		2.02	165.4	Yd. Lmts. TO-R 1535 <b>ORLAND</b> YP	21204	124.4	s 4.25	5.20
				167.0	R 2015 <b>WYO</b> P	21030	122.8	4.23	
PM 11.59	9.38		2.16	178.5	<b>CORNING</b> P	21025	111.3		5.05
AM 12.06	9.45	PM 3.15	2.28	186.3	<b>TEHAMA</b> YP } DT	20195	103.5	4.05	4.55
				211.7	<b>GERBER</b> P }	20190	101.4		4.50
				213.8	8305 <b>RAWSON</b> P	20178	96.3		
				218.9	TO-R 8345 <b>RED BLUFF</b> BKPQ	20173	91.8		
				223.4	8200 <b>BLUNT</b> P	20165	86.3		
				228.9	8445 <b>DRAPER</b> P	20160	78.6		
				236.5	9245 <b>CULP</b> P	20152	71.0		
				244.2	10820 R <b>GIRVAN</b> P	20140	61.7		
				253.5	5290 <b>REDDING</b> BKPQ	20110	57.0	s 3.10	
s 12.55				258.2	<b>SILVERTHORN</b> P	20067	52.2		
				263.0	5095 <b>CENTRAL VALLEY</b> P	20063	48.9		
				266.3	9350 <b>GRAY ROCKS</b> P	20058	44.8		
				270.4	6120 <b>O'BRIEN</b> P	20055	37.6		
				277.6	5095 <b>MEAD</b> P	20051	34.0		
				281.2	8300 <b>LAKEHEAD</b> YP	20045	29.5		
				285.7	5255 <b>DELTA</b> P	20033	25.4		
				289.8	5570 <b>LAMOINE</b> P	20029	21.9		
				296.7	4970 <b>GIBSON</b> P	20025	18.1		
				300.2	8300 <b>SIMS</b> P	20019	12.7		
				304.0	5385 <b>CONANT</b> P	20014	9.0		
				309.4	5805 <b>CASTLE CRAG</b> P	20005	3.8		
				313.1	<b>DUNSMUIR YARD</b> BKP	07255	0.9		1.30 PM
				318.3	TO-R <b>DUNSMUIR</b> BKYPQ	07250	0.0	1.30 AM	
				321.2					
				322.1					
Arrive Daily	Arrive Daily	Arrive Daily	Arrive Daily		(214.2)			Leave Daily	Leave Daily
<b>14</b>	<b>366</b>	<b>376</b>	<b>378</b>					<b>11</b>	<b>377</b>

**RULE 5. Tehama:** Time applies at junction switch.  
**RULE 5. Davis:** Time applies at station sign except time applies for No. 14 at east switch north siding.  
**RULE S-72. Exception:** No. 14 is superior to No. 377.

WEST VALLEY SUBDIVISION

Mile Post Location	EAST-WARD	Colusa Branch		Station Number	WEST-WARD Distance
		STATIONS SIDING CAPACITIES AND FACILITIES			
108.3	R	5360	P	21305	72.1
120.8		Yd. Lmts. GRIMES	P	21171	59.6
133.0		COLUSA		21156	47.4
150.4		CODORA		21137	30.0
170.0		2855 Yd. Lmts. HAMILTON	P	21113	10.4
180.4	R	1535 Yd. Lmts. WYO	YP	21030	0.0
(72.1)					
Knights Landing Branch					
84.9	Yd. Lmts.	4895 TO-R BKPQ WOODLAND		21340	3.3
87.7		SUGARFIELD		21404	0.5
88.24		END OF BRANCH			0.0
(3.3)					
Matheson Branch					
258.2	R	Yd. Lmts. REDDING BKPQ		20110	10.7
261.0		MIDDLE CREEK	P	20120	7.9
263.2		KETT	P	20125	5.7
268.9		MATHESON	P	20130	0.0
267.2					
(10.7)					

EAST VALLEY SUBDIVISION

Mile Post Location	EASTWARD	STATIONS SIDING CAPACITIES AND FACILITIES		Station Number	WEST-WARD Distance
		FIRST CLASS			
		376	LABRT		
		Leave Daily			
		PM 1.15			
106.6				23000	105.1
112.8				22579	98.9
117.0				22574	94.7
122.1				22567	89.6
134.2				22547	77.5
139.8				22531	71.9
140.8				22500	70.9
141.8				22404	69.9
144.7				22249	67.0
155.9				22235	55.8
158.0				22232	53.7
167.4				22220	44.3
178.1				22207	33.6
184.2				22030	27.5
193.6				22019	18.1
203.0				22011	8.7
211.7		3.15 PM		20195	0.0
		Arrive Daily			
		376			

Automatic Block Signal System  
Centralized Traffic Control

ADDITIONAL STATIONS				
Capacity and Direction of entry into Spurs	Mile Post	NAME	Station Number	
<b>Davis-Dunsmuir Line</b>				
1175W ..	92.1	Dufour..... (Spur)	21325	
835W P	103.2	Dunnigan..... (Spur)	21312	
1125E ..	106.4	Hershey..... (Spur)	21308	
1470E ..	113.5	Arbuckle..... (Spur)	21266	
1470E ..	117.6	Genevra..... (Spur)	21261	
590E ..	126.8	Delphos..... (Spur)	21251	
1370E ..	133.0	Maxwell..... (Spur)	21243	
3235E ..	156.8	Artois..... (Spur)	21214	
	162.0	Greenwood.....	21208	
390E P	181.6	Richfield..... (Spur)	21020	
..	215.8	Proberta.....	20182	
1960 ..	224.5	Glade.....	20170	
2645 ..	240.4	Cottonwood.....	20157	
	247.1	Anderson.....	20148	
<b>Colusa Branch</b>				
640E ..	143.2	Stegeman..... (Spur)	21145	
930E ..	162.1	Ordbend..... (Spur)	21123	
1960 P	178.6	Cory.....	21103	

ADDITIONAL STATIONS

Capacity and Direction of entry into spurs	Mile Post	NAME	Station Number	Capacity and Direction of entry into spurs	Mile Post	NAME	Station Number
<b>Roseville-Tehama Line</b>							
2450 P	118.4	Clayton.....	22572	.. R	147.6	Yuba City.....	22304
2745 ..	121.0	Ewing.....	22569	..	152.2	Oswald.....	22310
.. P	131.2	Erle.....	22551	440W ..	153.4	Blue Anchor..... (Spur)	22312
..	138.9	Rupert.....	22541				
685E ..	149.8	Sunset..... (Spur)	22242				
1570 P	151.5	Live Oak.....	22239	1420E ..	188.3	Stirling City Branch	
2400 P	161.4	Biggs.....	22228	980 ..	198.2	Butte Creek..... (Spur)	22105
295E ..	164.1	Riceton..... (Spur)	22224			Paradise.....	22116
.. P	191.3	Nord.....	22023				
1370 P	209.7	Los Molinos.....	22003				

141.8		BINNEY JCT. P	22404	
		(Via WPRR)		
147.9		OROVILLE	22430	
<b>Oroville Branch</b>				
147.9	Yd. Lmts.	OROVILLE	22420	0.0
144.5		VILLA VERONA	22410	3.4
(3.4)				
<b>Stirling City Branch</b>				
184.2	R	Yd. Lmts. CHICO BKYPQ	22030	31.2
215.4		STIRLING CITY Y	22140	0.0
(31.2)				
<b>Yuba City Branch</b>				
144.7	Yd. Lmts.	8450 BERG P	22249	12.4
144.4				
156.8		TUDOR	22319	0.0
(12.4)				

**SACRAMENTO DIVISION TIMETABLE No. 3, SEPTEMBER 15, 1974**

4

**ROSEVILLE SUBDIVISION**

<b>EASTWARD</b>		Mile Post Location	Station Number	<b>STATIONS</b> SIDING CAPACITIES AND FACILITIES	Distance from Sacramento
<b>FIRST CLASS</b>					
6	375				
Passenger	LABRT				
Leave Daily	Leave Daily				
AM 11.15		89.0 88.9	23050	TO-R SACRAMENTO BKIYPQ	0.0
		90.0	23040	SACRAMENTO (15th St.) P	1.1
	AM 11.57	91.8	23037	ELVAS IYPQ	2.9
		94.9	23021	BENALI P	6.0
11.35	PM 12.10	102.8	23008	ANTELOPE BKIPQ	13.9
11.42	12.25 PM	106.6	23000	TO-R ROSEVILLE BKIYPQ	17.7
		110.6	16480	ROCKLIN P	21.7
AM 11.58		120.2	16450	Yd. Lmts. NEWCASTLE P	31.3
		124.2	16440	AUBURN, NEVADA ST. P	35.3
PM 12.08		129.1	16425	E-4200 BOWMAN P	40.2
12.30		141.7	16300	E-6400 Yd. Lmts. COLFAX BKYPQ	52.8
		146.1 146.0	16270	TO-R CAPE HORN P	57.2
		152.2	16259	E-6400 GOLD RUN P	63.4
1.04		160.7	16242	MIDAS P	71.9
1.14		165.5 166.6	16234	BLUE CANON P	76.7
1.27		171.4	16229	M-5575 Yd. Lmts. EMIGRANT GAP IYPQ	81.5
1.43		179.0	16220	SHED 10 IP	89.1
		180.3	16217	CISCO P	90.4
1.56		185.5	16211	TROY P	95.6
2.10		192.0	16190	E-6495 TO-R NORDEN BKIYPQ	102.1
		197.3 198.7	16175	SHED 47 IP	107.4
2.21		208.0	16160	E-5020 Yd. Lmts. TO-R TRUCKEE BKIYPQ	116.7
s 2.40		222.4	16148	FLORISTON P	131.1
3.02		231.8	16133	VERDI P	140.5
3.15		242.9	16110	RENO P	151.6
s 3.50		246.2	16105	TO-R SPARKS BKYPQ	154.9
s 4.10 PM				(154.9)	
Arrive Daily	Arrive Daily				
6	375				

**RULE 5. NORDEN.** Time applies at station sign.

<b>EASTWARD</b>		Mile Post Location	<b>WESTWARD</b>	
<b>FIRST CLASS</b>			Station Number	Distance from Elvas
375	365			
LABRT	LABRF			
Leave Daily	Leave Daily			
AM 11.50	AM 7.25	132.0	23113	4.2
		133.2	23110	3.0
11.57 AM	7.32 AM	136.2	23037	0.0
Arrive Daily	Arrive Daily			
375	365			

Capacity and Direction of entry into spurs		Mile Post	NAME	Station Number
<b>ADDITIONAL STATIONS</b>				
<b>Roseville-Sparks No. 1 Track</b>				
490E	..	241.0	West Reno..... (Spur)	16122
1125E	P	238.0	Lawton..... (Spur)	16125
885W	P	216.2	Boca..... (Spur)	16154
..	..	200.9	Andover.....	16172
..	..	197.7	Eder.....	16176
880E	P	193.0	Summit..... (Spur)	16181
..	..	177.9	Crystal Lake.....	16221
880E	P	157.2	Towle..... (Spur)	16247
..	P	148.9	Magra.....	16265
<b>Roseville-Sparks No. 2 Track</b>				
540W	..	126.5	Foothill..... (Spur)	16430
..	P	148.5	Magra.....	16265
..	P	156.8	Towle.....	16247
..	..	177.9	Crystal Lake.....	16221
..	..	197.7	Eder.....	16176
..	..	197.7	Eder.....	16176
..	..	200.9	Andover.....	16172
..	P	216.3	Boca.....	16154
..	P	238.0	Lawton.....	16125
..	P	241.0	West Reno.....	16122

ROSEVILLE SUBDIVISION

Mile Post Location	STATIONS SIDING CAPACITIES AND FACILITIES	Station Number	WESTWARD		EASTWARD	Station Number	WESTWARD
			Distance from Sparks	FIRST CLASS 5 Passenger			
89.0 88.9	TO-R SACRAMENTO BKIYPQ	23050	156.4	PM 12.45			
90.0	SACRAMENTO (15th St.) P	23040	155.3				
91.8	ELVAS IYPQ	23037	153.5				
94.9	BENALI P	23021	150.4				
102.8	ANTELOPE BKIYPQ	23008	142.5	12.11 PM			
106.6	TO-R ROSEVILLE BKIYPQ	23000	138.7	12.06 PM			
110.6	ROCKLIN P	16480	134.7				
113.9	W-5500 LOOMIS P	16370	131.4				
116.6	PENRYN P	16360	128.7				
119.6	Yd. Lmts. NEWCASTLE P	16350	125.7	AM 11.33			
124.5	Yd. Lmts. AUBURN P	16340	120.8				
128.4	BOWMAN P	16330	116.9	11.16 AM			
142.1	W-5133 Yd. Lmts. COLFAX BKYPQ	16300	103.2	10.49 AM			
146.4	TO-R CAPE HORN P	16270	98.9				
152.6	GOLD RUN P	16259	92.7	10.20 AM			
161.1	MIDAS P	16242	84.2	10.03 AM			
166.0	BLUE CANON P	16234	79.3	9.53 AM			
170.7 171.4	M-5400 Yd. Lmts. EMIGRANT GAP IYPQ	16229	74.6	9.44 AM			
179.0	SHED 10 IP	16220	67.0	9.23 AM			
180.3	CISCO P	16217	65.7				
185.6	TROY P	16211	60.4	9.10 AM			
192.1	TO-R NORDEN BKIYPQ	16190	53.9	8.57 AM			
197.3 198.7	SHED 47 IP	16175	47.3	8.41 AM			
208.0	W-6220 Yd. Lmts. TRUCKEE BKIYPQ	16160	38.0	8.22 AM			
222.4	TO-R FLORISTON P	16148	23.7	7.59 AM			
231.7	VERDI P	16133	14.5	7.46 AM			
242.8 242.9	Yd. Lmts. RENO P	16110	3.3	7.30 AM			
246.2	TO-R SPARKS BKYPQ	16105	0.0	7.15 AM			
	(156.4)			Leave Daily			
				5			

Mile Post Location	STATIONS SIDING CAPACITIES AND FACILITIES	Station Number	WESTWARD
104.4	CITRUS	23131	1.9
106.3	FAIR OAKS	23135	0.0
(1.9)			
Walnut Grove Branch			
89.0 88.7	Yd. Lmts. TO-R SACRAMENTO BKIYPQ	23050	33.2
97.5	FREEPORT	23214	24.4
104.6	HOOD JCT.	23221	17.3
113.4	Yd. Lmts. WALNUT GROVE	23243	8.5
121.9	ISLETON	23250	0.0
(33.2)			
Placerville Branch			
94.7	Yd. Lmts. R BRIGHTON IP	23110	55.0
96.4	PERKINS	23117	53.3
98.9	MAYHEW	23122	50.8
101.6	MILLS	23127	48.1
104.4	Yd. Lmts. R CITRUS	23131	45.3
110.1	NATOMA	23141	39.6
111.1	Yd. Lmts. R FOLSOM JCT. Y	23143	38.6
118.0	WHITE ROCK	23158	31.7
142.7	EL DORADO	23184	7.0
145.0	DIAMOND SPRINGS	23186	4.7
149.7	Yd. Lmts. TO-R PLACERVILLE	23190	0.0
(55.0)			

RULE 5. NORDEN. Time applies at station sign.

ADDITIONAL STATIONS			
Capacity and Direction of entry into spurs	Mile Post	NAME	Station Number
Placerville Branch			
1520W ..	97.5	Manlove.....(Spur)	23119
635W ..	107.4	Nimbus.....(Spur)	23138
245 ..	131.4	Dugan.....	23175
735 ..	131.7	Bullard.....	23177
245W ..	147.7	Apex.....(Spur)	23189
Walnut Grove Branch			
.. ..	91.8	Baths.....	23204
.. ..	94.2	Del Rio.....	23208
8380W ..	105.3	Hood (on spur from Hood Jct.).....	23226
.. ..	107.9	Lambert.....	23231
735E ..	111.2	Mofuba.....(Spur)	23235
Sacramento-Roseville Line			
.. ..	92.9	Johnston.....	23032
1470 ..	93.5	Swanston.....	23028
.. ..	97.5	Planehaven.....	23015
.. ..	99.4	Walerga.....	23012
Polk-Sacramento Line			
980E ..	134.6	Hopfen.....(Spur)	23105

**SACRAMENTO DIVISION TIMETABLE No. 3, SEPTEMBER 15, 1974**

6

**SPARKS SUBDIVISION**

EAST- WARD FIRST CLASS  6 Passenger Leave Daily	Mile Post Location	STATIONS SIDING CAPACITIES AND FACILITIES		Station Number	Distance from Carlin	WEST- WARD FIRST CLASS  5 Passenger Arrive Daily
		Yd. Lmts. TO-R	BKYPQ			
		STATIONS				
PM 4.35	246.2	SPARKS	P	16105	288.3	AM 6.50
	249.1	VISTA	P	16055	285.4	
	253.1	5990 HAFED	P	16049	281.4	
	257.3	5875 PATRICK	P	16043	277.2	
	262.1	5745 CLARK	P	16035	272.4	
	266.2	9600 THISBE	P	16030	268.3	
	276.1	10100 FERNLEY	YPQ	16020	258.4	
	284.5	9400 DARWIN	P	16010	250.0	
	288.1	6500 HAZEN	P	14160	246.4	
	292.5	6185 MASSIE		14157	242.0	
	302.0	10200 UPSAL		14148	232.5	
	311.7	9600 PARRAN		14137	222.8	
	320.0	9860 OCALA		14129	214.5	
	328.4	9620 TOY		14121	206.1	
	336.8	9940 GRANITE POINT		14110	197.7	
	340.5	PERTH		14090	194.0	
	344.3	W-6450 E-6075 LOVELOCK		14082	190.2	
	357.8	M-6200 OREANA		14067	176.7	
	366.0	RYE PATCH		14059	168.5	
	377.0	HUMBOLDT		14048	157.3	
	384.1	IMLAY		14041	150.2	
	388.7	MILL CITY		14035	145.6	
	397.0	COSGRAVE		14027	137.3	
	406.6	ROSE CREEK		14016	127.7	
	406.8					
	417.3	6950 WINNEMUCCA	PQ	14005	117.2	
7.15	420.9	WESO (WP Conn.)	IP	12198	113.6	3.54
	422.8	TULE		12194	111.7	
	439.3	PREBLE (WP Conn.)		12185	95.2	
	448.1	6050 IRON POINT		12180	86.4	3.29
	466.3	7550 MOTE		12171	68.2	3.13
	475.8	6500 TO BATTLE MOUNTAIN	PQ	12162	58.7	3.05
	492.9	7580 MOSEL		12156	41.6	2.50
	508.2	7100 TO BEOWAWA (WP Conn.)	P	12145	26.3	2.37
	520.3	BARTH (WP Conn.)	P	12137	14.2	2.26
s 9.05 PM	534.5	Yd. Lmts. TO-R CARLIN (WP Conn.)	BKYPQ	12129	0.0	2.10 AM
Arrive Daily		(288.3)				Leave Daily
6						5

Centralized Traffic Control  
 Automatic Block Signal System  
 Double Track  
 C.T.C.

EAST- WARD Mile Post Location	STATIONS SIDING CAPACITIES AND FACILITIES		Station Number	WEST- WARD Distance
	Yd. Lmts. TO-R	BKYPQ		
	STATIONS			
358.7	WENDEL	P	08398	22.3
349.8	HERLONG	I	08510	13.4
336.4	ABS { FLANIGAN } IP	IP	08540	0.0
(22.3)				

Oregon Division stations Herlong and Wendel shown for information only.

Mina Branch				
	Yd. Lmts.			
288.1	HAZEN	P	14160	128.9
307.0	3070 APPIAN	P	14320	110.0
328.0	4025 TO WABUSKA	P	14341	89.0
354.2	3130 SCHURZ	P	14367	62.8
384.4	2200 TO THORNE	P	14370	32.6
408.2	LUNING	P	14380	8.8
417.0	Yd. Lmts. TO-R MINA	BKYP	14395	0.0
(128.9)				

Fallon Branch				
	Yd. Lmts.			
288.1	R HAZEN	P	14160	15.8
303.9	FALLON	YP	14210	0.0
(15.8)				

ADDITIONAL STATIONS				
Capacity and Direction of entry into Spurs	Mile Post	NAME	Station Number	
1715W	P	Wunotoo . (Spur)	16038	
590E	P	Kodak . . (Spur)	14077	
4210		Colado . . (Spur)		14075
2550E	P	"		
980W		"		
1325W		"		
1640E	P	Golconda . (Spur)	12189	
245E	P	Valmy . . (Spur)	12175	
3185E	P	Argenta . (Spur)	12159	
245E		Harney . . (Spur)	12141	
2790E	P	Palisade . (Spur)	12134	
Mina Branch				
615	P	Weeks . . . . .	14327	
2630		Fort Churchill .	14343	
..		Lux . . . . .	14345	
..		Reservation . . .	14361	

Time shown for eastward first class trains at Weso and Carlin for information only. See Western Pacific Railroad timetable for eastward train movements between Weso and Carlin.

**SACRAMENTO DIVISION TIMETABLE No. 3, SEPTEMBER 15, 1974**

**OGDEN SUBDIVISION**

<b>EASTWARD</b>				Mile Post Location	<b>STATIONS</b>				Station Number	Distance from Ogden	<b>WESTWARD</b>			
<b>FIRST CLASS</b>					SIDING CAPACITIES AND FACILITIES						<b>FIRST CLASS</b>			
6					Passenger						5			
			Passenger											
			Leave Daily											
			PM 9.15	534.5				12129	248.6			AM 2.00		
				554.3				12120	228.8					
			f 9.37	556.2				12112	226.9			s 1.30		
				576.7				12109	206.4					
				589.6				12107	193.5					
				591.1				12101	192.0					
			10.25 PM	603.6				10190	179.5			12.38 AM		
				607.5				10185	175.6					
				616.4				10180	166.7					
				624.6				10172	167.7					
				632.5				10164	159.0					
				640.6				10160	151.3					
				644.8				10149	142.5					
				661.9				10131	138.3					
				679.8				10125	121.2					
				685.1				10116	102.5					
				693.7				10108	97.2					
				702.1				10099	88.6					
				711.1				10089	80.2					
				720.7				10078	71.2					
				729.5				10072	61.6					
				734.6				10067	52.8					
				739.7				10061	47.7					
				745.2				10053	42.6					
				752.9				10050	37.1					
				755.2				10039	29.4					
				767.2				10037	27.1					
				776.3				10000	15.1					
			s 2.15 AM	782.3					6.0			9.45 PM		
			Arrive Daily						0.0			Leave Daily		
			6									5		

**STATIONS**  
SIDING CAPACITIES AND FACILITIES

Yd. Lmts. TO-R CARLIN (WP Conn.) BKYPQ

Yd. Lmts. TO ELKO P

5430 TO ELKO P

7600 HALLECK

5500 DEETH

WPRR Connection

ALAZON (WP Conn.)

E-6145 W-5080 W-6680 WELLS KYPQ

9480 HOLBORN

9700 PEQUOP

W-9715 VALLEY PASS

COBRE

E-8670 W-6180 MONTELLO P

E-5930 W-8130 LUCIN

9580 PIGEON

9630 JACKSON

9590 LEMAY P

9650 GROOME

9670 HOGUP

9575 STRONGKNOB

LAKESIDE LAKESIDE No. 1 Track

TRESEND TRESEND

9620 MIDLAKE

BRIDGE BRIDGE

SALINE

M-6240 LITTLE MOUNTAIN

WEST WEBER

Yd. Lmts. TO-R OGDEN BKYPQ

(247.8 Eastward) (248.6 Westward)

Automatic Block Signal System

CTC DT CTC

Double Track

Centralized Traffic Control

Double Track

Time shown for eastward first class trains at Carlin and Elko for information only. See Western Pacific Railroad timetable for eastward train movements between Carlin and Alazon.

<b>ADDITIONAL STATIONS</b>			
Capacity and Direction of entry into Spurs	Mile Post	NAME	Station Number
..	P	544.7 Moleen .....	12124
2350E	P	564.8 Osino .....	12118
..	..	568.4 Ryndon .....	12117
..	P	573.1 Elburz (W.P. Conn.) .....	12116
..	P	758.5 Promontory Pt. ....	10045
<b>Eastward Track</b>			
600E	..	669.3 Tecoma .....	10142

## SPECIAL INSTRUCTIONS—ALL SUBDIVISIONS

**RULE A.** Employees must know they have in their possession copy of Rules and Regulations of the Transportation Department, effective January 1, 1969.

**RULE M.** Fourth paragraph is revised to read:

Employees are prohibited from getting on roof of cars except when necessary to make repairs.

Fifth paragraph of Rule M is cancelled in its entirety.

### DEFINITIONS

**HOLIDAYS** are revised to read:

New Year's Day, January 1,  
Washington's Birthday, Third Monday in February,  
Decoration Day, Last Monday in May,  
Independence Day, July 4,  
Labor Day, First Monday in September,  
Thanksgiving Day, Fourth Thursday in November,  
Christmas Day, December 25.

Restricted Speed is revised to read:

"Restricted Speed. Proceed prepared to stop short of train, obstruction, stop signal or switch not properly lined and look out for broken rail, not exceeding twenty miles per hour."

**RULE 3.** First paragraph is revised to read:

Conductors, yard-engine foremen, engineers and outside hostlers must compare their watches with a standard clock before commencing each day's work. Conductors and yard-engine foremen must, when practicable, compare time with their engineers before starting each trip or each day's work. At the first opportunity other members of the crew must compare time with the conductor, yard-engine foreman or engineer.

**RULE 7-B.** Switchmen must use green flag by day and green light by night or oral instructions in giving proceed signals for movement of trains at Sacramento, Roseville, and Sparks, except that at Roseville proceed signal for movement to or from East Valley Subdivision yellow flag by day and yellow light by night must be used.

Conductors, yard-engine foremen, engineers and outside hostlers must compare their watches with a standard clock before commencing each day's work. Conductors and yard-engine foremen must, when practicable, compare time with their engineers before starting each trip or each day's work. At the first opportunity other members of the crew must compare time with the conductor, yard-engine foreman or engineer.

**RULES 10-G, 10-H and 10-1.** When unattended red flags or red lights, yellow flags, red CONDITIONAL STOP signs and yellow PROCEED PREPARED TO STOP signs are displayed between siding switches, they must be duplicated to the right of siding in direction of approach. If clearance between siding and main track does not permit display of these flags or signs to the right of track in direction of approach, flags or signs may be displayed to the left of track in direction of approach. Display of these flags or signs to the left of track in direction of approach must be respected as though they were displayed in accordance with these rules.

**RULES 10-H and 15.** On all branch lines, except: Between Hamilton and Wyo on Colusa Branch, and between Brighton and Folsom Junction on the Placerville Branch, and, for westward trains on Stirling City Branch, and on Mina Branch MP 288.62 to MP 328.00, yellow flags will be displayed one-half mile from point of restriction, and when a torpedo is exploded in the vicinity of a yellow flag displayed in accordance with Rule 10-H, train must proceed expecting to find an unattended red flag that may be displayed one-half mile beyond the torpedo and the yellow flag.

**RULE 10-J.** Speed signs prescribing an increase in speed will not be installed on branches. Speed Restrictions tables will indicate permissible speeds between mile post locations named.

Second and fourth paragraphs are revised to read:

Speed signs that prescribe reduction in speed will be located two miles from initial point of restriction, and where used to authorize increase in speed will be located at point where higher speed commences. Speed may be increased as soon as rear of train has passed speed sign. Where such signs are not used to authorize an increase in speed, limit of restriction will be shown in timetable.

Certain speed signs have the word "SIGNAL" above the figures. Such signs in advance of signal indicate the speed that must not be exceeded while engine is passing signal two miles beyond the speed sign, unless signal can plainly be seen to be displaying green aspect.

**RULE 14(I).** Where there are multiple public crossings not more than one-fourth mile apart, sign bearing letter "X" located one-fourth mile in advance of first crossing will display a figure which represents the number of crossings involved.

Whistle signal under provisions of Rule 14(1) must be sounded until engine has passed over last crossing.

**RULE 15.** Each torpedo placed will be duplicated on opposite rail during snow storms, or when snow on rails.

**RULE 21.**

First paragraph of Rule 21 revised to read:

Trains must be identified by engine number on lead unit when practicable. Only the number designated for identification will be continuously illuminated when engine is so equipped.

Trains handling loads of excess dimensions covered by train order must be identified in CTC, Interlocking and on double track.

**RULE 26.** On diesel fueling tracks, a blue light will not be attached to reflectorized blue "MEN AT WORK" signs when displayed at night.

**RULE S-72.** Westward trains are superior to trains of the same class in the opposite direction.

**RULE 98.** Cars must not be kicked, dropped or shoved over railroad crossings not protected by interlocking, unless movement is protected.

**RULE 101.** When member of crew has reason to believe train has passed over defect in track or roadbed that may interfere with safe train movement, the following precautions must be taken:

- (1) Train stopped immediately and inspection made to ensure train is safe to proceed.
- (2) Train dispatcher and opposing or following trains must be immediately notified of condition encountered. Train dispatcher must, if means are available, afford protection for opposing and/or following trains until advised that reported defect has been inspected by Maintenance of Way forces.
- (3) To provide such protection, train dispatcher will arrange to stop train movements over the reported defect, except when crew that reports the defect indicates conditions allow, movement through the location may be authorized at restricted speed.
- (4) If train dispatcher cannot be contacted or if train dispatcher cannot afford appropriate protection, crew of train first encountering defect must afford protection.

**RULE 102.** Should a passenger train break in two or an emergency application of brakes occur while in motion on grade, head brakeman will immediately go towards rear, close angle cock at opening if train has parted, set hand brakes, and turn up retaining valves on detached portion. After train is coupled air must be applied from engine before hand brakes and retaining valves are released.

**ADD:**

At any time a train in motion has emergency application of air brakes for any cause, before proceeding an inspection of train must be made on both sides to determine all wheels are on rail and no damage or defects in track exist which will interfere with safe movement of train.

**RULE 103-A.** On tracks other than main tracks where crossing is protected by automatic gates or other automatic Crossing Protection and "STOP SIGNS" are located approximately twenty-five feet (25 ft.) each side of crossing, movements must stop at "STOP SIGN" and allow gates to lower or other automatic protection to operate twenty seconds before entering crossing.

Trains moving under conditions that may require them to stop must, where possible, stop to clear public grade crossings. When not possible to stop clear of such crossings, and train cannot proceed immediately, crews on other than passenger trains must cut these crossings within ten minutes unless no vehicles are waiting at or closely approaching the crossing. Public crossings must be left open until it is known that trains are ready to depart. Crews required to pick up, set out or perform switching operations must, when track room exists, stop their trains back a sufficient distance to avoid blocking public crossings when coupling trains and while charging train lines. When recoupling at public crossings, trains shall be moved promptly consistent with safety.

Switching movements over public grade crossings should be avoided whenever possible. If not possible, such crossings must be cleared frequently to allow vehicles to pass and must not be occu-



ped continuously for longer than ten minutes unless it can be seen that no vehicles are waiting at or closely approaching the crossing.

Cars or locomotives must not be left standing nor switches left open within the controlling circuits of automatic gate protection devices unless timeout features are provided to allow the gate arms to rise.

**RULE 105.** Capacity of sidings column indicates length of train in feet that can be accommodated between fouling points.

Sidings designated "E" in capacity of sidings column are assigned for use by eastward trains; those designated "W" are assigned for use by westward trains. Those designated "N" for North and "S" for South are assigned for use by trains as shown in special instructions for the subdivision on which located.

**RULE 211 and Form "N" Train Order:**

When operators advance a train at a station under Rule 211, Example (3), the following wording must be used:

"This is S.P. Operator (station). I have a Form 'N' train order to advance (train) on main track until (time)."

**RULE 285.** First paragraph under Name and Aspect, is revised to read:

Trains exceeding medium speed must reduce to medium speed before engine reaches the signal if advance view of signal permits.

**RULE 286.** When distant signals governing movements on controlled sidings display yellow aspect, train may proceed on siding at restricted speed expecting to find siding occupied by preceding train.

First paragraph of Rule 286 under Name and Aspect, is revised to read:

Trains exceeding medium speed must reduce to medium speed before engine reaches the signal if advance view of signal permits.

**RULE 290-A.** Revised to read: INDICATION: PROCEED WITHOUT STOPPING NOT EXCEEDING RESTRICTED SPEED PREPARED TO STOP SHORT OF NEXT HOME SIGNAL.

**RULE 505. AUTOMATIC BLOCK SIGNAL SYSTEM**

**PUSH BUTTONS**

Where signal protection is provided for movements from an adjacent track to main track, push buttons and lights are installed in box near each of the two signals, with time-release feature, to clear signals on one track when the control circuit on the other track is occupied.

Train on main track to let train on siding pass may clear signal on siding by pressing button bearing number of signal on siding. Train on siding to let train on main track pass should not pass Approach Circuit sign, but when necessary to do so, may clear signal on main track by pressing button bearing number of signal on main track. Further instructions posted inside push button box.

**ELECTRIC OR MECHANICAL SWITCH LOCKS**

Where electric or mechanical switch locks are installed, be governed by instructions posted in telephone booths, on doors or on housings of electrical or mechanical switch lock.

**RULE 507. ADD:** On single track within yard limits, when an automatic block signal displays stop indication, engines, after stopping, may proceed at restricted speed under the following conditions:

- (1) When a preceding train is seen in the block and intervening track is seen to be clear.
- (2) When view of track is clear to end of block.
- (3) After waiting five minutes and no train or engine is seen or heard approaching.

**INTERLOCKING**

**RULE 663(b).**

Operator (or dispatcher where applicable) may authorize movements under provisions of this rule after it has been ascertained

indication lights on control panel are illuminated indicating dual control switches are in proper position and locked for movement without requiring dual control switches to be placed in hand position as required by Rule 772.

When indication light on control panel are not illuminated movements may be authorized under provisions of this rule; however, before making a movement over dual control switches, such switches must be placed in hand position in accordance with Rule 772 and locked until movement over switch has been completed. When movement has been completed, switch must be returned to normal position and selector lever restored to motor position and locked.

When member of crew examines switch to see that points are in proper position for movement, examination must be made on the ground.

**RULE 705. HOT BOX DETECTORS**

If means of communication is available, engineer must inform conductor and helper engineer, if any, when approaching hot box detector. Crews on helper engine and on rear end of train must acknowledge and advise engineer of indications displayed in addition to taking appropriate action in accordance with applicable rules and special instructions.

Actuation of hot box detector requires train to be immediately stopped for inspection. To accomplish this without causing journal to seize from the brake application, dynamic brake must be used when practicable. When working power and hot box detector has been actuated, brakes should be applied with an initial reduction, reducing power and applying dynamic brake as soon as possible consistent with good train handling, adding to the reduction as may be necessary to complete the stop.

Except for emergency situations, train and engine crews must avoid using radio transmitter within 500 feet from or beyond Hot Box Detector scanner site.

Hot box detector scanner sites have a white light continuously displayed on track side of instrument house, except when a hot bearing is detected, at which time light will start flashing. Crew members must keep a vigilant lookout for light and, when flashing, conductor and engineer must immediately orally compare observation when means of communication is available. Absence of white light must be promptly reported to train dispatcher.

Instructions follow for operations of hot box detectors when stopped by illuminated letter, flashing white light, or rotating red beacon actuated by hot bearing.

**TYPE A. Letter "H" indicator with Digital Readout:**

When letter "H" is illuminated or it is known hot bearing has been detected by crew member observing the flashing white light at scanner site, train must be stopped promptly and inspection made to determine that it is safe to proceed. Where possible, inspection must be made before passing over switches or structures. After inspection, train must not exceed 15 MPH from point of inspection until stop is made at location of readout indicator and be governed by instructions posted inside case.

When letter "W" is illuminated train must stop and wait until indicator is extinguished or permission is obtained from train dispatcher to proceed. Telephone located near "W" indicator.

When hot box detector is activated, member of crew must make a physical count of axles from rear of train to axle indicated by digital readout and when hot bearing is not located then all bearings of car indicated by detector as well as five cars on either side of the car involved must be inspected.

When "H" indicator indicates a hot bearing on train and there is no count shown on hot bearing detector and/or red light below readout marked "Locator Out of Service" is illuminated or when digital readout indicator displays a false indication such as a duplication of numbers or the numbers displayed exceed the number of axles in train, then all bearings of train must be inspected.

After inspection has been completed train dispatcher must be notified of condition found. When it is safe to proceed, member of crew must push button below indicator panel to cancel numbers on the indicator. Case door must be closed and secured with switch lock.

**TYPE B. Light Indicator Array:**

Detector instrument house is equipped with indicator array consisting of white lights and revolving red beacon as shown in diagram.

White light at top center of indicator array will be continuously displayed except when a hot bearing has been detected at which time

## SPECIAL INSTRUCTIONS—ALL SUBDIVISIONS

## HOT BOX BEARING DETECTOR INDICATOR ARRAY

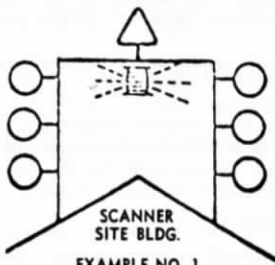

EXAMPLE NO. 1

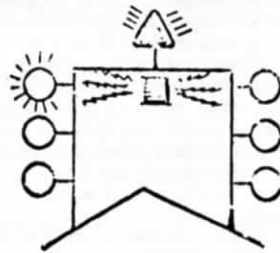
DETECTOR IN OPERATION  
NO HOT BEARINGS

EXAMPLE NO. 2

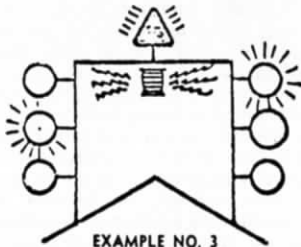
DETECTOR IN OPERATION  
ONE HOT BEARING ON LEFT SIDE

EXAMPLE NO. 3

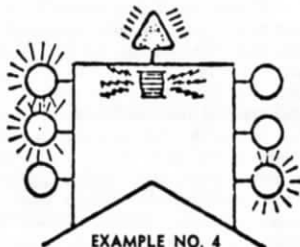
TWO HOT BEARINGS  
1ST FROM HEAD END ON RIGHT SIDE  
2ND FROM HEAD END ON LEFT SIDE

EXAMPLE NO. 4

THREE HOT BEARINGS  
1ST FROM HEAD END ON LEFT SIDE  
2ND FROM HEAD END ON LEFT SIDE  
3RD FROM HEAD END ON RIGHT SIDE

## LEGEND

UNILLUMINATED

ILLUMINATED

FLASHING

INDICATOR LAMP (WHITE)



ROTATING RED BEACON



WHITE (IN SERVICE) LIGHT

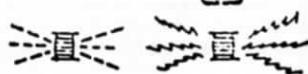

light will start flashing. Absence of white light must be promptly reported to train dispatcher.

Revolving red beacon at top center of indicator array will be normally dark except when a hot bearing has been detected, beacon will be actuated.

Three vertical white lights are located on each side of indicator array. Lights on right side will be displayed for hot bearings on right side of train, and lights on left side will indicate hot bearings on left side of train, in direction of movement. Top light indicates first hot bearing, second light indicates second hot bearing, and third light indicates third hot bearing. Lights will indicate a maximum of three hot bearings on each train.

Crew members must keep vigilant look-out when passing these locations, and if hot bearing is detected, train must be stopped promptly, and inspection made to locate car with hot bearing. In addition, truck of car with hot bearing will be sprayed with fluorescent dye marker for identification. All bearings on car marked, as well as car ahead, must be inspected.

When indicator array indicates hot bearing on train, and no dye marker is observed, all bearings of train must be inspected.

## TYPE C. Monitor Display Board with Indicator Lights.

A Monitor Display Board and hot box indicator lights, as shown in diagram, are mounted on a signal mast at side of track. As the train passes the detector, the right or left hot box indicator light on top of the board starts to flash immediately upon detection of a hot bearing, indicating the side of the train having the overheated journal. Two seconds after the train passes the detector, the display board will display numerals indicating the accumulated axle count from the hot bearing to the rear of the train.

A flashing indicator light in the center indicates that another hot bearing (or bearings) was detected subsequent to the hot bearing which is numerically indicated on the display board. Flashing lights, both left and right but not in the center, indicate two hot bearings,

same axle, numerals displayed indicating axle count from that axle to the rear of the train. Flashing center light, together with either the left or right light only, indicates the hot bearings detected were all on the same side of the train. All three indicator lights flashing signify the indicated hot bearing may be on either side and that one of the subsequent bearings was on the opposite side.

The display board is illuminated as train passes and will display zeros in the absence of a hot bearing. Absence of any numerical display after passage of a train must be promptly reported to train dispatcher.

Also upon detection of a hot bearing white light which is continuously lit on equipment house adjacent to Monitor Display Board will start to flash. Absence of white light must be promptly reported to train dispatcher.

When any indicator light displays flashing white aspect, train must be stopped promptly and inspected. If only one flashing aspect is indicated, the axle number from rear of train shall be inspected plus all bearings of the car indicated by detector as well as each adjoining car. If center light displays flashing white aspect, all bearings from count indicated to rear of train shall be inspected on side or sides as indicated by left or right flashing white light. Lights and illuminated numerals will automatically cancel out ninety (90) seconds after entire train passes detector.

When hot box detector is actuated member of crew must make physical count of axles from rear of train to axle indicated by display board. When hot bearing is not located then all bearings of car indicated by detector as well as five cars on either side of the car involved must be inspected.

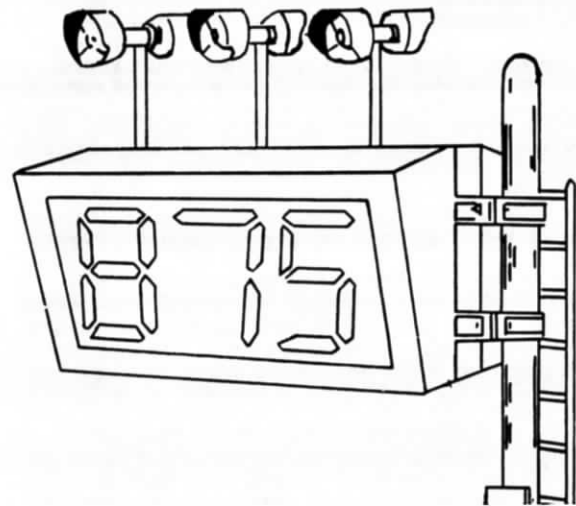

TYPE D. Remote Readout by Recorder at Terminal:  
Readout is by recorder located at nearby terminal as shown under Rule 705 on each subdivision of Special Instructions.

Hot box detector scanner sites have a white light continuously displayed on track side of instrument house, except when a hot bearing is detected, at which time light will start flashing. Absence of white light must be promptly reported to train dispatcher.

Crew members must keep a vigilant lookout for light and, when flashing, conductor and engineer must immediately orally compare observation when means of communication is available. Train must be stopped promptly and when means of communications is available, crew member must contact employe at location of recorder to determine location of hot bearing. If location of hot bearing cannot be determined, inspection must be made of all bearings.

## REPORTING OF HOT BOXES

When hot box detectors are actuated, the following information is to be reported at next terminal in telegraph message form identified by symbol H.B., addressed jointly to Superintendent, Division Engineer, Signal Supervisor, and Chief Train Dispatcher; also General Manager-Amtrak, San Francisco, when an Amtrak passenger train is involved.

1. Date and time stopped, and M.P. location.
2. Train identification.
3. Car number and location in train.

4. Box location (1, 2, 3 or 4 from trailing end of car in direction of movement, right or left side).
5. Disposition of car: If set out, state where. If inspection shows that it was not necessary to set out even though bearing was warm enough to activate the detector, advise what corrective action was taken to permit movement of car. If roller bearing equipped, so state.
6. Report all cases where train passes over the detector without an indication having been displayed, but develops a hot bearing between detector and a point 20 miles beyond detector.

#### CENTRALIZED TRAFFIC CONTROL

##### **RULE 765.** First sentence is revised to read:

When necessary to perform switching moves requiring more than one reverse and one normal movement over any main track or controlled siding switch and track is unoccupied, member of crew must request, and train dispatcher will designate, work limits and clock time limit that must not be exceeded.

**RULE 776(a).** When member of crew examines switch to see that points are in proper position for movement, examination must be made on the ground.

**RULE 781.** White light which may appear on side of signal housings adjacent to switch is maintainers call light, but when train has been stopped by an absolute signal and white light is observed burning, member of crew will communicate with train dispatcher except when a train is closely approaching.

#### GENERAL REGULATIONS

**RULE 804. ADD:** Employees are, unless authorized by an officer of the Company, forbidden to have in their possession while on the property firearms, concealed or otherwise, or any other weapon considered dangerous.

**RULE 810. ADD:** Continued failure by employees to protect their employment shall be sufficient cause for dismissal.

##### **RULE 822.** Ninth paragraph is revised to read:

When necessary to climb through cars, employees may, when practicable, cross only through those standing cars equipped with end platforms or over the body of an empty flat car. They must not place any part of their body between coupler horn and end sill regardless of whether car is equipped with standard draft gear arrangement, sliding sill arrangement or end-of-car cushioning device. Crossing through moving equipment is prohibited.

**ADD:** When train is starting, stopping, or moving slowly, employees on train must maintain a secure position to avoid personal injury from possible slack action.

Trainmen shall not be inside caboose when caboose is involved in switching moves or when caboose is being coupled to or uncoupled from train.

##### **RULE 824. SETTING OUT CARS EQUIPPED WITH AB or ABD AIR BRAKE EQUIPMENT:**

Any time an angle cock is closed in the train where the brake pipe pressure is lower than it is elsewhere, the resultant equalization will raise the brake pipe pressure at that point sufficient to release the AB or ABD valve. Equalizing the air in the brake pipe will cause release of brakes throughout the cars. Therefore, it is imperative that when cars are set out, regardless of the air brake equipment, a sufficient number of hand brakes must be applied and brake pipe pressure completely depleted by opening angle cock and **LEAVING THE ANGLE COCK IN OPEN POSITION.**

**RULE 825.** At terminals where instructions require application of hand brakes on freight trains, outgoing crews must not release hand brakes until road engine is coupled and brake system charged.

A sufficient number of hand brakes must be set to hold cars; if two cars or more, not less than two (2) must be set.

Rail skids are hung on posts at locations listed under subdivisions. When using rail skid it must be placed on rail and leading wheel of first car in descending direction run onto rail skid and hand brakes set if brakes are operative before engine is detached. Train crews picking up cars from these locations must remove rail skid, return to proper location and lock in place where lock is provided.

**RULES 825 and 883.** Cars with short wheel base, less than 30 feet inside length as stencilled on side of car, should not be left standing on main track in automatic block signal territory, interlocking limits, CTC limits or on CTC sidings unless coupled to another car to prevent possibility of short wheel base car occupying dead section of track.

**RULE 827.** Engines running light on descending grade without dynamic brake in operation must stop a sufficient length of time to permit wheel heat radiation if there is **INDICATION OF OVERHEATING.**

Dragging equipment detector and/or derail equipment detector mounted on post adjacent to detector will display revolving red light when detector is actuated. Crew members must keep vigilant lookout when passing and if revolving red light observed, train must be stopped promptly and inspection made of train and track, notifying train dispatcher of condition found.

If means of communication is available, Engineer must inform conductor and helper engineer, if any, when approaching hot box detector, dragging equipment detector, excess dimension load detector or person making rolling inspection of his train. Crews on helper engine and on rear end of train must acknowledge and advise engineer of indications displayed in addition to taking appropriate action in accordance with applicable rules and Special Instructions.

**RULE 830.** At interlocked railroad crossings at grade, cars or engines must not be cut off nor left within interlocking limits in such a way as to foul any part of the crossing frogs.

**RULE 837.** When making yard movements on any work lead or an adjoining track thereto, the movement will have the right to move on the track for which the switches are properly lined. If switch is lined against the movement, or for an adjacent connected track, the movement must not proceed until it is safe to do so. Position of the switches will govern the right of movement regardless of whether or not they are spring, rigid, or variable.

**RULE 883.** Light engines must not be left unattended on grades unless protected in descending direction by derail or spur track switch lined for diverging track. Air brakes must be applied and hand brake on each unit of consist must be applied and chain must be placed under wheels.

First sentence in first paragraph is revised to read as follows:

When an engine is left without an employe in charge, it must when practicable, be placed on track affording protection against entry to main track; hand brakes must be fully applied, wheel secured with blocking chain or if not available other suitable blocking material, reverse lever removed from control stand, generator field switch OFF, engine isolated and cab doors locked.

**RULE 958** is revised to read:

Employees shall identify the radio station from which they are calling by prefacing their call with the railroad name, for example: "SP Caboose Train Second 802 calling SP Engine Second 802, over" and to answer a call, announce, for example: "This is SP Caboose Train Second 802, over".

Radio station must be identified at the end of each transmission which exceeds three minutes, except that, in event of continued exchange of communications, identification shall be made at the end of each 15-minute period if the exchange continues without substantial interruption.

**RULE 962.** First sentence is revised to read:

Radio communication system may be used in lieu of hand, flag or lamp signals prescribed by Rule 12.

**RULE 963(d).** Is revised to read:

Train dispatcher communicating direct with engineer or conductor, after assured train is stopped, may authorize train to pass an absolute signal displaying stop indication within CTC limits as prescribed by Rule 776.

#### AIR BRAKE RULES

**RULE 2.** Dead engines and live engines not equipped with control cables for multiple operation must not be picked up by light engines. If necessary to pick up such engines, they will be picked up only by freight trains or locals.

**RULE 2-A.** When continuous wheel slip and/or ground relay action is experienced on a unit, the unit should not be isolated and

## SPECIAL INSTRUCTIONS — ALL SUBDIVISIONS

allowed to remain in the engine consist unless inspection definitely reveals that all wheels are rotating freely.

When using engine brake, it must according to conditions, be operated in such manner as to avoid overheating of brake shoes and wheels.

On departure from maintenance facility, engineers must determine by making running air brake test that the independent and automatic brakes are operating effectively.

**RULE 2-B.** First sentence in second paragraph is revised to read:

When going from power to dynamic braking proceed as follows:

- (1) Assure that throttle is in idle position.
- (2) Move selector lever to "off" position.
- (3) Pause 10 seconds.
- (4) Move selector lever to 'B' or braking position.
- (5) Use throttle or dynamic brake handle to control strength of dynamic braking as needed.

Dynamic brake on head end of freight trains must not exceed 24 axles.

If the maximum 24-axle limit cannot be adhered to due to units in the consist not having dynamic brake cutout switches, then such units must be isolated prior to using dynamic brake.

When dynamic brake and automatic air brake are used together, the independent brake valve handle must be depressed and held in release position a sufficient time to ensure engine brakes are released.

**RULE 3.** A full independent brake application on road engine classes EP 636, GF 628, EF 630, EF 636, EF 642, GF 630, GF 633, and EF 623 results in a brake cylinder pressure of 72 psi. This brake cylinder pressure must be maintained to provide required braking power at very low speeds or when stopped. Under no circumstances must self-lapping portion of independent brake valve be changed except to obtain brake cylinder pressure of 72 psi from a full independent brake application.

**RULE 11.** Cars equipped with brake cylinder release valve may have one or two operating release rods. Operating rod connected to brake cylinder release valve may be identified by stencil reading "Br. Cyl. Rel.," or by a diamond shaped stencil or by noting that ends of release rods form a small closed circle. Air brakes can be released on cars equipped with brake cylinder release valve by a hard momentary pull on release rod after brake pipe pressure has been depleted.

### **RULE 12. SETTING OUT CARS EQUIPPED WITH AB OR ABD AIR BRAKE EQUIPMENT:**

Rules require that when cars are set out and a sufficient number of hand brakes are applied brake pipe pressure must be depleted by opening angle cock. This method of securing cars is applicable to cars equipped with AB air brake equipment or cars equipped with the latest type of air brake equipment, the ABD valve.

**RULE 13.** Second paragraph is revised to read:

In case the trouble cannot be corrected or complete air failure occurs from any cause, train must not be moved. Train dispatcher must be promptly notified.

Sixth paragraph is revised to read:

Should the compressor or main reservoir on the lead engine fail the train must be stopped, automatic brakes left applied, dead-engine feature cut in and control of the brakes transferred to the second engine. The train must not be moved beyond the next point where an engine with suitable air equipment can be placed in the lead.

Seventh paragraph is CANCELLED in its entirety.

**RULE 14.** Engine controlling train must have brake pipe cut off valve in cut in position. Engine(s) not controlling train must have brake pipe cut off valve in cut out position. 26C Automatic Brake Valve handle must be placed in "HANDLE OFF" position. Handle must be left in this position to be available for emergency application if necessary. Independent Brake Valve must be cut in and handle in place.

**RULE 17.** If, at any time in engineer's judgement, use of retaining valves is required, stop will be made and retaining valves turned up in accordance with his request.

**RULE 22.** When two or more trains or engines are working at locations where Mechanical Department forces are not on duty, employees must not couple air hoses or go on, under or between cars

for the purpose of making repairs until a member of the crew has notified employees on other trains or engines in the immediate vicinity, and yardmaster, where assigned, that work is about to be performed and complete understanding had to prevent movement on the affected track.

First paragraph revised to read:

All trains, except for run-through and unit run-through trains covered in Rule 22-B, must be given inspection and test as specified in this rule at points: (1) Where a train is originally made up (Initial Terminal); (2) Where train consist is changed other than by adding or removing a solid block of cars and train brake system remains charged; and (3) Where train is received in interchange.

### **ADD RULE 22-B. Air Brake Tests on Run-Through and Unit Run-Through Trains.**

Each *run-through train* must be given inspection and test as prescribed by Rule 22 at points: (1) Where train is originally made up (Initial Terminal); (2) Where train consist is changed other than by adding or removing a solid block of cars and train brake system remains charged.

Each *unit run-through train* must be given inspection and test as prescribed by Rule 22 at points: (1) Where train is originally made up and where it is reassembled after being broken up; (2) and once during each round-trip cycle at designated points.

At these designated points inspection and tests must be made to determine the piston travel of a body-mounted 10-inch brake cylinder does not exceed 10 inches; and piston travel on all other brakes must not exceed the nominal travel specified by more than 2 inches or exceed the maximum travel specified by the badge plate or stencil on the car.

At a point where a block of one or more cars is added to a run-through train or a unit run-through train after the train is originally made up, cars must be inspected and tested as prescribed by Rule 22. At a point other than a terminal where a block is added, inspection and tests must be made as prescribed by Rule 24-C.

Inspection and tests made under Rule 22 must be recorded at the time they are performed by completing FRA Form F-6180-48 in duplicate. This form must be signed by employee responsible for the inspection and tests. One copy of the form shall be kept in the cab of the engine until the train arrives at its final terminal. In the event of change of head-end power between terminals, engineer must insure that this form accompanies train.

At locations where the crew of one carrier takes over control and operation of a run-through train or unit run-through train from the crew of another carrier, the receiving carrier shall inspect and test the train to determine that:

- (1) The cab of the engine contains a completed FRA Form F-6180-48.
- (2) Brake pipe leakage does not exceed 5 pounds per minute.
- (3) Brakes apply and release on the rear car from a 20-pound service brake pipe pressure reduction.

If the cab of the engine does not contain a completed FRA Form F-6180-48, the train must be inspected and tested as prescribed by Rule 22 before it proceeds.

**RULE 23.** The following series of cars are equipped with ABEL brake system which has automatic changeover feature to provide proper brake function when car is loaded and when empty:

SSW 75700 - 75799	Gondolas
SSW 78500 - 78599	Hoppers (Open Top)
SP 333500-334399	Gondolas
SP 337500-337599	Gondolas
SP 345000-345669	Gondolas
SP 354000-354749	Gondolas
SP 463500-464899	Hoppers (Open Top)
SP 467500-467549	Hoppers (Open Top)
SP 480000-480193	Hoppers (Open Top)
SP 491000-491059	Hoppers (Covered)
SP 492000-492039	Hoppers (Covered)
SP 500604	Flat Car
SP 590000-590099	Flat Cars

The following series of cars are equipped with ABDEL brake system, which has automatic change-over feature to provide proper brake function when car is loaded and when empty. This feature is fully automatic on these series and requires no action on part of engineer:

SP 337600-337699	Gondolas
SP 354750-355099	Gondolas
SP 595500-595624	Cradle Flats

**RULE 25.** Conductor must contact engineer at designated locations and inform him of the air brake pressure shown on the caboose gage. Engineer must immediately repeat the air brake pressure figure back to the conductor. If radio communication is not distinct train must be stopped by use of automatic air application. Train may proceed after complying with Air Brake Rule 6.

**RULE 26.** When temperature is 32 degrees or less, running test may be made (Rule 29) in lieu of last paragraph of Air Brake Rule 26.

Engineer will, after informing train crew in caboose that running test is to be made, make sufficient brake pipe reduction and allow sufficient time for brakes to apply on caboose before releasing brakes.

Trainmen will observe that brakes apply on caboose and that brake pipe pressure as shown on caboose gauge is being properly restored and notify engineer accordingly.

When temperature is 32 degrees above zero or less, air brake system on locomotive must be blown out before coupling to train, as follows:

Place automatic brake valve handle in running position, then open angle cock at rear of locomotive, move brake valve handle suddenly to release position, causing heavy flow of air throughout the brake pipe, which should blow out any condensation that may have accumulated in the brake system.

Before road test is made on any freight train after locomotive has been coupled thereto, blow out air brake pipe hoses on head end of train as follows:

After making a 20-pound brake pipe reduction, close angle cocks between second and third cars, uncouple air hose; close angle cocks between first and second cars, uncouple air hose; close angle cocks between first car and locomotive, uncouple air hose. During this test enginemen must drain condensation from lead unit by opening drain cocks and blowing out condensation from air compressor inter-cooler and aftercooler, main reservoirs, control reservoir, dirt collectors, air filters and strainers. After recoupling hoses and reopening angle cocks, release train brakes. Before proceeding, it must be known that brake pipe pressure, as indicated on caboose gage at rear of train is properly restored.

If unable to obtain proper air brake test while running, train must be stopped and air brake hose on head end blown out as prescribed in last paragraph Air Brake Rule 26.

**RULE 33.** Loaded cars with empty-load (ABEL or ABDEL) brakes are to be considered the equivalent of one and one-half (1½) cars in determining tons per operative brake.

**RULE 60.** On descending grades train air brakes must be used in conjunction with dynamic brakes unless air brake application would cause train to either stop or retard speed excessively below that which is authorized.

MISCELLANEOUS

1. HELPER SERVICE:

The following covers engine tractive effort in pounds:

ENGINE MODEL	CLASSIFICATION	TRACTION EFFORT POUNDS
SW1200...	ES412.....	62,250
C415.....	AS415.....	62,750
RS32.....	AF420.....	63,750
GP9.....	EF418-1 to 9; EF418C-1-2; EF418E-1-2-3.....	64,200
SW1500...	ES415-1-2-3-4-5-6.....	65,000
RS11.....	AS418-1-2-3-4-5-6.....	65,000
GP20.....	EF420-1-2; EF420C-1-2.....	65,100
GP35.....	EF425-1-2-3-4; EF425C-1-2-3.....	66,000
GP30.....	EF-423-1; EF423C-1.....	66,100
GP40.....	EF430C-1.....	67,560
U25B.....	GF425-1-2-3.....	67,800
U28B.....	GF428-1.....	67,890
SD7.....	ES615-1-2-3-4.....	82,500
SD9.....	EF618-1 to 5; EF618E-1-2.....	89,700
RSD15.....	AS624-1.....	92,500
SD35.....	EF625-1.....	95,540
C628.....	AS628-2.....	97,750
C630.....	AS630-1.....	101,000
.....	AS600-1.....	102,000
SDP45.....	EP636-1.....	102,500

ENGINE MODEL	CLASSIFICATION	TRACTION EFFORT POUNDS
SD45-2....	EF636-7-8-9; EF636C-6-7-8.....	102,600
SD40.....	EF630-1-2.....	102,750
U28C.....	GF628-1.....	103,120
SD45X....	EF642-1-2.....	103,240
SD45.....	EF636-1 to 6; EF636C-1 to 5.....	103,470
SD38.....	ES620-1.....	104,000
SD39.....	EF623-1-2.....	104,150
U33C.....	GF633-1 to 5.....	104,710
U30C.....	GF630-1-2.....	104,850
DD35.....	EF850B-1.....	131,750
U50.....	GF850.....	139,250

For classification of engines see item 3.

- (a) Rule for entraining when only one helper engine:
  - (1) On trains of less than 100 cars, helper engine consisting of not more than two six-axle operating units totaling 179,400 pounds tractive effort nor more than two four-axle operating units totaling 135,600 pounds tractive effort or a combination of one four-axle and one six-axle operating unit totaling 157,600 pounds tractive effort may be placed behind caboose.
  - (2) Helper engine consisting of only one unit on trains of 100 or more cars may be placed behind caboose.
  - (3) Helper engine that does not qualify under (1) or (2) must be entrained as near as practicable to shove 1/3 and pull 2/3 of tonnage handled by helper engine.
- (b) Trains having more than one helper engine must have each engine entrained as near as practicable so that it will shove 1/3 and pull 2/3 of tonnage handled.
- (c) Trains powered with two helper engines, one of which qualifies to be placed behind caboose, must entrain the non-qualifying helper as near as practicable to shove 1/3 and pull 2/3 of tonnage handled by the non-qualifying helper.
- (d) Not more than 3500 tons may be placed behind rear helper engine.
- (e) When helper is used on train handling empty coil cars in series SP 595500 to SP 595624 helper engine must be entrained ahead of these cars.
- (f) AS415, AF420, ES412 and ES415 class units must not be cut into train in helper service. No more than two of these units may be placed behind caboose.
- (g) Helper engine must not be placed on head end of train without authority being obtained from train dispatcher.
- (h) Air must be cut in on all helper engines and engine must not be coupled nor uncoupled while train is in motion.
- (i) Road engineer and helper engineer must communicate any change affecting the operation of their train when means of communication are available. When communication is not available, and speed is being held above 8 MPH on ascending grade, helper engineer must regulate amperage during speed reductions or speed increases to maintain the amperage indicated before speed change; if speed of train drops below 8 MPH or when coming to a stop on ascending grade, helper engineer must regulate amperage during speed reduction to maintain the amperage indicated before speed change, then close throttle just before train stops.
- (j) When speed of trains powered with 12000 or more horsepower on the head end and with helper engine entrained drops below 16 MPH, road engineer must reduce throttle to Run 6.

Loss of helper unit or units resulting in train speed dropping below 16 MPH and head end power being reduced to Run 6 may result in helper power working in short time rating. The short time rating must not be exceeded. If it appears that short time rating will be exceeded, assistance must be requested from train dispatcher. If assistance cannot be obtained, grade must be doubled.

**SPECIAL INSTRUCTIONS — ALL SUBDIVISIONS**

(k) In locating helper engine(s) in train, the following example of calculating tonnage for road engine and helper engine(s) will be used.

Example:

Train: 42 loads, 87 empties, 5756 tons  
 Four unit road engine (2-U30C, 1-SD39, 1-SD35)  
 Three unit helper engine (2-SD39, 1-SD40)  
 Total road horsepower 10800  
 Total helper horsepower 7600  
 Total horsepower 18400

(1) Divide total horsepower by tonnage =  
 $\frac{18400}{5756} = 3.196 \text{ HP/T}$

(2) Divide road horsepower by HP/T factor =  
 $\frac{10800}{3.196} = 3379 \text{ tons}$   
 Road engine will handle 3379 tons

(3) Divide helper horsepower by HP/T factor =  
 $\frac{7600}{3.196} = 2377 \text{ tons}$

(4) To determine 1/3 of helper tonnage divide  
 $\frac{2377}{3} = 792 \text{ tons}$   
 Helper engine will shove 792 tons.

(5) To determine 2/3 of helper tonnage multiply  
 $792 \times 2 = 1584 \text{ tons}$   
 Helper engine will pull 1584 tons

**2. PLACEMENT OF RESTRICTED CARS IN TRAIN WITH OR WITHOUT HELPER**

(a) Between Roseville and Dunsmuir and Roseville and Sparks, empty 70 foot long or longer equipment must be entrained ten or more cars behind road engine and ten or more cars ahead of helper engine. A flat with one van or one container, whether loaded or empty, must be considered as an empty. These instructions will not apply to trains LABRF, LABRT, BROAT, OABRT, BRLAT, UPSFF, OAOGM, UPOAM or OAOGH.

(b) When average weight of cars in trains, other than locals or switchers, is more than 60 tons per car do not handle any cars which weigh less than 50 tons within five cars of road engine. These instructions will not apply to trains operating between Roseville and Oakland via Davis.

(c) Flat cars USAX and DODX series 38016-38665 and USAX and DODX series 39095-39199 have been placed in TOPS Pool #0642 and are restricted to movement on rear of train and behind any helper.

**3. CLASSIFICATIONS ARE DESCRIPTIVE OF THE ENGINES AS FOLLOWS:**

1st letter.....Builder: A-Alco: B-BLH: E-EMD: F-Fairbanks Morse: G-GE

2nd letter.....Type of service: F-Freight: P-Passenger: S-Switcher

1st number.....Number of axles

2nd and 3rd numbers.....Horsepower (100)

Last letter.....Style of unit: A Car body type with control cab. B No control cab. C-SSW. E-SP Equipment Co. No letter indicates road switcher type

**4. SPEED RESTRICTIONS FOR ENGINES:** Maximum speed shown below is subject to further restriction applicable to certain territories as shown in Speed Restrictions for Trains:

**MAXIMUM SPEED AND LENGTH OF ENGINES**

CLASSIFICATION	ENGINE NUMBERS	MAXIMUM SPEED EXCEPT #	LENGTH (FEET)
AS600.....	1000-1002.....	70	70

CLASSIFICATION	ENGINE NUMBERS	MAXIMUM SPEED EXCEPT #	LENGTH (FEET)
ES406.....	1004.....	45	44
AS407.....	1025.....	60	44
ES408.....	1100-1128.....	65	44
ES408B.....	1150-1153.....	65	44
ES409.....	1170-1179.....	65	44
AS409.....	1200-1281.....	60	45
ES410E.....	1300-1337.....	65	44
ES615.....	1400-1442.....	70	61
AS410.....	1778-1845.....	60	45
ES410.....	1904.....	60	44
BS412.....	2100-2157.....	60	46
ES412C.....	2250-2261, 2289-2293.....	65	44
ES412.....	2218-2223, 2262-2288.....	65	44
ES412E.....	2294-2307.....	65	44
FS412.....	2350-2394.....	60	46
AS415.....	2400-2409.....	65	54
ES415.....	2450-2480, 2493-2510, 2523-2578, 2591-2689.....	65	45
ES415C.....	2481-2492, 2511-2522, 2579-2590.....	65	45
AS418.....	2900-2936.....	70	57
AS618.....	2950-2970.....	70	58
ES620.....	2971-2976.....	70	69
EP418.....	3000-3010.....	79	56
FP624.....	3020-3035.....	70	66
AS624.....	3100-3102.....	25*	67
AS618.....	3110-3120.....	25*	69
AS630.....	3140-3153.....	25*	69
EP636.....	3200-3209.....	70	71
EF418E.....	3300-3393, 3730-3758.....	70	56
EF418.....	3413-3640, 3653-3727.....	70	56
EF418C.....	3641-3652.....	70	56
EF618.....	3816-3964.....	70	61
AF420.....	4000-4009.....	70	57
EF420C.....	4030-4049.....	70	56
EF420.....	4050-4087.....	70	56
EF618E.....	4300-4376.....	70	61
EF618E.....	4450.....	70	61
EF423C.....	5000-5009.....	70	56
EF423.....	5010-5017.....	70	56
GS407.....	5100-5120.....	55	37
EF623.....	5300-5325.....	70	66
EF425C.....	6500-6519, 6680-6681.....	70	56
EF425.....	6520-6679.....	70	56
GF425.....	6700-6767.....	70	60
EF625.....	6900-6928.....	70	61
GF428.....	7025-7028.....	70	60
AF628.....	7100-7128.....	70	69
GF628.....	7150-7159.....	70	67
EF430C.....	7600-7607.....	70	59
GF630.....	7900-7929.....	70	67
EF630.....	8300-8306, 8350-8356.....	70	66
EF630.....	8400-8488.....	70	66
GF633.....	8600-8785.....	70	67
EF636.....	8800-8963, 8982-9051, 9069-9151, 9166-9260, 9302-9343.....	70	66
EF636C.....	8964-8981, 9052-9068, 9152-9165, 9261-9301.....	70	66
EF642.....	9500-9505.....	70	71
EF850B.....	9900-9902.....	70	88
GF850.....	9950-9952.....	70	84
Amtrak Locomotives:			
EP415A.....	SP Model F7.....	79	51
EP415B.....	SP Model F7.....	79	50
	UP Model E8, 9A.....	70	51
	UP Model ES, 9B.....	70	70
SDP-40-F.....	540-649.....	70	72
Any locomotive not listed.....		35	

\*When operated in multiple unit control, on head end of train or running light and engineer is in other than the leading control cab in direction of movement, speed must not exceed 30 MPH. 'A' type units (indicated by letter 'A' following classification numerals) operating in reverse as lead unit in direction of movement must not exceed 30 MPH.

\*May be handled isolated in multiple, dead in multiple, or dead in train at maximum speed of 70 MPH.

NOMINAL CLASS	RUNNING FORWARD WITH TRAIN OR LIGHT	RUNNING BACKWARD WITH TRAIN OR LIGHT**
WPRR..... 551-564.....	35	35
WPRR..... 559-564 in mul.....	30	30
WPRR..... 601-606.....	30	30
WPRR..... 701-713, 725-732.....	65	60
WPRR..... 1501-1503.....	65	45
WPRR..... 2001-2010.....	70	60
WPRR..... 2251-2265.....	70	60
WPRR..... 3001-3022.....	70	60
WPRR..... 3050-3071.....	70	60
WPRR..... 3501-3544.....	70	60

\*\*When operated in multiple unit control with engineer in other than lead unit in direction of movement must not exceed 30 MPH.

D&RGW & UP diesel units, when used, will be permitted maximum freight train speeds but will not exceed maximum speed stenciled in cab of each unit.

SNRY and CCT engines will not exceed speed restrictions for engines shown in SNRY and CCT timetables and maximum speed is subject to further restrictions applicable to certain territories as shown in speed restrictions for trains.

Engines handled dead must not exceed speed shown in table.

**5. OTHER INSTRUCTIONS.**

a. Light engines on descending grade without dynamic brake in operation must not exceed Column 2 speeds.

b. Dead diesel locomotives weighing 100,000 pounds or more will be placed first behind locomotive handling train; locomotive weighing less than 100,000 pounds must be placed near rear of train.

c. Dead or disabled engines, and equipment listed in timetable which requires movement at reduced speed must first be reported as ready to move to the chief train dispatcher, who will designate the train in which the engine or equipment is to be moved. Any such engine must not be handled in train until train-order designating maximum speed is issued.

d. Engines operated with engineer in other than lead unit in direction of movement, must not exceed 20 MPH when approaching highway or street crossing at grade, subject to further restrictions imposed by local conditions.

e. Movement of foreign line engines, in service or dead in train, must not be authorized until provisions of current Line Clearance Circular have been complied with.

f. When a unit or units in locomotive consist emit excessive smoke through exhaust stacks other than from a cold start, prompt report must be made to train dispatcher who will arrange to notify roundhouse foreman or locomotive maintenance forces on duty at first maintenance facility where train is scheduled to stop. Unit number, time and location where excessive smoking of unit was first observed should be reported.

When a yard engine is observed emitting excessive smoke report must be made to roundhouse foreman or locomotive maintenance forces on duty.

In addition, engineer should make appropriate entry on work report, Form CS 2326.

g. AS415, AF420, ES412 and ES415 class engines must not be moved dead in train. These engines must be MU'ed in engine consist.

h. When only AS415, AF420, ES412 and ES415 units are used in engine consist, not more than two units may be on the line when making a reverse movement with cars or train and must be located adjacent to the train.

i. When operating with mixed engine consist, where dynamic brake is required, not more than two AS415, AF420 and ES415 units will be used.

- (1) If one unit is used, it will be placed as the second unit.
- (2) If two units are used, units must be placed as the second and third units in consist.
- (3) A road unit must be coupled against the train.
- (4) If necessary to make a reverse move with cars or train, lead unit must be isolated.

NOTE: ES412 class units 2212-2257 will not be used in mixed consist account not equipped with #24 MU wire.

j. If necessary to operate with more than two AS415, AF420, ES412 and ES415 class units in consist (including pick up of units from outlying points), these units must be placed in the lead. Under

these conditions, if reverse move is made with cars or train, all units ahead of the two rear units in these classes will be isolated.

k. Extreme caution must be used during dynamic braking or when making reverse moves to prevent jackknifing and track damage.

l. Not more than ten diesel units in operation may be used on head end of any freight train.

6. MAXIMUM SPEED PERMITTED WITH CERTAIN EQUIPMENT	MPH MAIN TRACKS OTHER THAN BRANCHES	MPH MAIN TRACKS ON BRANCHES
Double or triple loads.....	...	25
Scale test cars, except.....	40**	30
SPMW 2024, WO-3.....	65	49
<i>Locomotive Cranes:</i>		
(SPMW 4027, 4080, 4088, 4091, 4542, 4543, 5479, 5849, 5595, 6601 and 6602		
With boom disconnected and counterweight forward.....	45	25*
EXCEPT SPMW 5595.....	40	25*

MAXIMUM SPEED PERMITTED WITH CERTAIN EQUIPMENT	MPH MAIN TRACKS OTHER THAN BRANCHES	MPH MAIN TRACKS ON BRANCHES
With boom disconnected and light end forward.....	20*	15
With boom in place, either end forward.....	25*	15
<i>Steam Pile Drivers:</i>		
SPMW 3402		
With leads removed and secured.....	45	25*
SPMW 4052 and 4053.....	35	25*
Relief outfits with steam derrick, except.....	45*	25*
Relief outfits 7070 and 7110 must not exceed 35 MPH* and relief outfit 7050 must not exceed 30 MPH* on main tracks other than branches. Relief outfits 7070 and 7110 must not be operated on any branch.		
Rotary snow plows:		
Electrified.....	35	15

\*These speeds must not be exceeded, and on curves where authorized speed is more than 15 MPH speed must be reduced to 5 MPH less than shown in timetable and on speed signs.

\*\*Scale Test Car NBS-1 to be handled on trains not more than 20 cars ahead of caboose and speed of train handling NBS-1 not to exceed 60 MPH.

7. OTHER MAXIMUM SPEEDS	MPH PASSENGER TRAINS	MPH FREIGHT TRAINS
Passenger trains, with caboose.....	65	...
Engine and caboose only, except.....	...	65
must not exceed speed for same engine running forward light.		
Engine and flanger only, except.....	...	40
On curves.....	...	35
Logs loaded on flat or logging cars, except.....	...	35
On curves.....	...	25
Through truss bridges, tunnels and passing stations.....	...	15
SP 595500-SP 595624 (coil steel flats).....	...	45

8. Rotary snow plows will not clear certain structures, tunnels and cuts with wings extended; be governed by instructions posted in rotary cab.

Rotary snow plows must come to stop when train or engine is passing on adjoining track.

Flangers operating in snow territory must raise flanger blades and stop while train or engine is passing on adjacent track.

Maximum speed for flangers is 40 MPH.

9. When moving against current of traffic, or when movement is not protected by block signals, speed of passenger trains and light engines must not exceed 59 MPH, and speed of freight trains must not exceed 49 MPH, nor may speed exceed that applying to normal operation. Unless proceed signal received, or it is known that warning devices are operating, such trains and engines must stop approaching road crossings where automatic warning devices are installed, and may proceed after member of crew protects crossing.

Unless otherwise authorized, trains handling passenger cars with flat spots on wheels in excess of 3/4 inches in length must not exceed 10 MPH. When flat spots are not in excess of 3/4 inches long such cars may be operated at maximum authorized speeds.

10. Forward brakeman on freight trains will ride the lead unit *when a seat is available*.

**LOAD LIMIT**

11. Where 315,000 pound load limit applies:

Gross weight of 315,000 pounds applies to uniformly loaded four axle cars with minimum axle spacing of 6'-0" and minimum distance of 37'-0" center to center of trucks; also wheels 38" or more in diameter.

Where 263,000 pound load limit applies:

Gross weight of 263,000 pounds or less applies to uniformly loaded four axle cars having trucks spaced 23'-0" or more center to center and minimum axle spacing of 5'-6".

12. Cars SPMW 6400-6439 (100-ton Air Dump) have gross weight of 263,000 pounds (car and contents). These cars are not to be operated on lines shown in each Subdivision where allowable gross weight is exceeded. These cars are not to be dumped on curves of 25 degrees or more, or operated through curves of 35 degrees or more.

13. Trailer flat cars, tri-level automobile carrying cars and 30,000-gallon "Super Tanker" tank cars, all 80 and 85 feet long. "Jumbo" tank cars HYDX 701 to 706, inclusive, loaded or empty, without authority of Chief Train Dispatcher must not be operated on any branch, on west leg of wye at Chico, or on industry, yard tracks, or interchange tracks within Sacramento yard limits. These cars can be operated on 12th St. yard tracks, new yard, 6th St. yard, levee tracks, freight leads, back leads and Depot No. 1, in Sacramento.

Freight cars of a height greater than fifteen (15) feet six (6) inches, except cars transporting highway trucks or trailers, multi-level freight cars either loaded or unloaded, and automobile under-frame cars, shall be entrained at least five (5) cars distant from caboose if train length permits.

14. Except where specifically authorized, cabooses are not to be moved other than at rear of trains.

15. Freight trains containing no restricted cars may operate at Column 1 speeds not exceeding 65 MPH when authorized by train order except where restricted to Column 2 speeds, provided trains do not exceed:

Number of cars	Tons per Operative Brake
70	70
75	69
80	68
85	67
90	66
95	65
100	64
105	63
110	62
115	61
120	60
125	58
130	56
135	54
140	52
145	50



**RULE 21.** Identification of superior trains via Corning may be made at Red Bluff or between Red Bluff and Tehama and such identification will apply at Tehama.

**RULE 82A.**

Westward regular trains via Corning must be authorized at Red Bluff by clearance bearing the OK, time and initials of the Chief Train Dispatcher and specifying green or no signals as required.

**Redding:** Extra trains originating at Redding and operating on the Matheson Branch between Redding and Matheson, will display engine number on the lead unit leaving Redding and are authorized to operate as extra trains between Redding and Matheson.

Extra trains and engines operating in below listed territories must register destination of trip, turning point, and date and time of departure in column captioned "Signals." When trip has been completed, date and time of arrival at initial station of trip must also be entered in column captioned "Signals." Extra trains or engines on route into these territories must not leave the initial station until it has been ascertained from the train register that all preceding trains or engines via the route to be used have completed their trips and registered time and date of arrival at initial station of trip accordingly:

Territory	Register Location
Matheson Branch	
Redding-Matheson .....	Redding

**RULE 83-A.** At the following stations, only the trains indicated will register:

- Woodland — Trains originating or terminating.
- Harrington — Trains specified by train order.
- Orland — Trains originating or terminating.
- Wyo — Trains specified by train order.
- Redding — Trains originating or terminating.
- Red Bluff — Regular trains via Corning and trains originating or terminating.
- Dunsmuir — Freight trains originating or terminating.

**RULE 83-B.** At open train-order offices, trains may register by ticket as follows:

- Davis — All trains to or from West Valley Subdivision.
- Red Bluff — Regular trains via Corning.

**RULE 85.** A section must not pass and run ahead of another section of the same schedule in CTC limits or on double track between Red Bluff and Tehama without first exchanging train orders with the section to be passed, each section to display signals if necessary.

**RULE 93.** Yard limits in which the provisions of Rule 93 will apply are established at the following stations:

West MP	East MP
74.20	Davis (Dixon line) ..... 77.37
	Davis (Tehama line) ..... 78.00
83.66	Woodland ..... 85.82
	Woodland (Knights Landing Branch, end of Branch) ..... 88.24
147.96	Willows ..... 150.84
164.48	Orland ..... 167.72
177.62	Wyo (Colusa Branch) ..... 177.62
120.00	Grimes ..... 122.00
169.00	Hamilton ..... 171.00
	Redding (Matheson Branch) ..... 259.23

**RULE 97.** Extra trains must not operate via Colusa Branch unless authorized by train order.

**RULE D-97.** Applies from CTC limit at east end Gerber to CTC limit at west end Tehama.

**RULE 99.** Will not apply on Matheson Branch.

**RULE 99-C.** Will apply on Colusa Branch, and between Tehama and Davis.

**RULE 103-A.** Trains and engines must stop and be preceded by flagman before crossing highway at:

- Woodland.....Main St. crossing on house track.
- Orland .....Spur Track No. 3339, serving Murco Produce crossing Tehama Street.

**WOODLAND.** Stop signs installed on Ogden Lead at Cross Street and on Ogden Lead and House Track at Oak Street. Protection to traffic must be afforded before moving over these crossings.

Passenger trains stopping at Redding station will stop clear of impulse circuit indicated by white marker on platform, to permit crossing gates to raise. When train starts, proceed slowly to permit gates to lower after passing impulse circuits. Sound detector microphones adjacent to track just east of Yuba St. for westward movements and just west of Tehama St. for eastward movement. Trains stopped to receive or discharge traffic must sound whistle to activate gates and crossing must not be entered until gates are down.

**RULE 104.** The normal position of rigid switches at junctions:

- Woodland.....Knights Landing Branch, for movement from siding to Knights Landing Branch,
- Harrington ...Colusa Branch, for siding,
- Wyo .....Colusa Branch, for siding,
- Redding.....Matheson Branch, for Silverthorn line.

**RULE 105.**

**Davis:** North siding is first track west of main track on Gerber line extending from MP 76.03 to MP 76.75.

**Wyo:** Siding is second track of the two tracks paralleling main track.

**Redding:** Siding is first track on south side of main track extending from MP 258.68 to MP 256.58. This is not a controlled siding and all movements must be made with caution not exceeding 15 MPH.

**RULE 204.** Trains to or from East Valley Subdivision with the same conductor and engineer operating through Tehama may be issued train orders on East Valley Subdivision or West Valley Subdivision that affect their movement on either of these subdivisions.

**RULE 221.** Red Bluff is a train order office for westward trains via Corning only.

**RULE D-251.** Applies between MP 211.88 Tehama, and MP 214.9 Gerber, on eastward and westward main tracks.

**RULE 291. Dunsmuir Yard:** Unit for display of flashing yellow installed on mast of westward absolute signals at west end main track and siding, MP 319.61.

**RULE 306.** The following block signals, equipped with triangular plate displaying the letter "P," have included in their control limits some special protective device.

**SPECIAL INSTRUCTIONS—WEST VALLEY SUBDIVISION**

Eastward	Protection	Westward
P-1132	Collision barricade detector, MP 113.3	P-1137
P-1182	High water detector, bridge 118.88	P-1197
P-1368	High water detector, bridge 137.10	P-1381
P-1748	High water detector, bridge 176.21	P-1769
P-A	Spring switch west end siding Redding	
P-2388	High water detector, Bridge 239.88	P-2403
P-2720	Fire detector, Pit River Bridge	P-2743
P-2720	Slide detector fences, MP 273.70 and 274.10	P-2743
P-2882	Fire detector, bridge 288.50, and Slide detector fence, MP 296.00	P-A
P-A	Slide Detector Fence, MP 301.2	P-3013
P-3012	Slide Detector Fence, MP 301.4	P-3023
P-A	Slide areas east of Lamoine, MP 300.6 to MP 300.8 and MP 301.3 to MP 301.5	P-3017
P-3024	Slide detector fence, MP 302.70	P-A
P-3050	Slide detector fence, MP 305.60	P-3061
P-A	Slide Detector Fence, MP 310.2	P-3111
P-846	Collision detector barricade MP 85.30	P-855
P-846	Collision barricade detector, MP 85.4	P-855
P-898	Collision barricade detector, MP 89.7	P-903
P-886	Collision barricade detector, MP 88.7	P-897

**AUTOMATIC BLOCK SIGNAL SYSTEM**

**RULE 516.** Overlap posts:

**Westward Trains:** Wyo—at fouling point east switch of siding.

**SPRING SWITCHES**

**RULE 538.** Spring switches equipped with facing point locks are located as follows:

Location	Normal Position
Redding	West end siding
	Main track

**RULE 705. LETTER TYPE INDICATORS**

Indicators located as follows:

Illum. Letter	On Signal	Approaching	Authorizes and requires movement as follows:
S	P-A	Redding, west switch	Enter siding
W	MP 319.9	South 1st St. Crossing, Dunsmuir Yard.	West trains on main track or sidings when indication illuminated must stop short of South 1st St. crossing and wait until illumination extinguished.

**RULE 705. HOT BOX DETECTORS**

Illum. Letter	On Signal	Approaching	Location of Readout
H	2387	Draper	Westward Absolute Signal W.E. Draper
W	2388	Culp	
W	2403	Draper	
H	2418	Culp	Eastward Absolute Signal E.E. Culp

**SCANNER SITE**

MP	Type	Direction	Location
92.6	C	East and West	Dufour
120.6	C	East and West	Williams
154.8	C	East and West	Artois
179.7	C	East and West	Corning
240.0	A	East and West	Draper-Culp
267.5	C	East and West	Central Valley-Gray Rocks

Refer to Rule 705—All Subdivisions.

**RULE 760. CENTRALIZED TRAFFIC CONTROL**

Limits extend from eastward absolute signal at east end double track, Gerber, to east switch, Dunsmuir.

**TEHAMA:** Eastward "SA" signal at west switch of west crossover Tehama on West Valley route governs movement through crossover to eastward main track; eastward "SA" signal west of Tehama crossovers on East Valley route governs movements to eastward main track.

Westward two-unit "SA" signal at west end double track Tehama on westward main track:

- Top unit governs movement to West Valley route.
- Bottom unit governs movement to East Valley route.

Westward dwarf "SA" signal at west end double track Tehama on eastward main track governs movements to either West or East Valley route.

**Redding:** Dwarf type indicator for display of flashing white light located on siding, west side of South Street, and when displayed will authorize train to proceed on siding to absolute signal at east end siding. Restrictions that may be imposed by other signals or Rule 513, must be complied with.

Indicator for display of illuminated "Wait" located on mast of main track signal 2582 at east switch No. 1 track. When illuminated, requires eastward trains to wait west of South Street.

When held by these indicators, member of train crew must contact train dispatcher by phone and be governed by his instructions.

Three-unit absolute signal at the east end of siding at Lakehead governing westward trains is equipped with a "call-on" signal.

- Top Unit . . . . . Governs movement on main track,
- Middle Unit . . . . . Governs movement to siding,
- Bottom Unit . . . . . Governs movement to house track,
- Call-on Signal (Flashing Yellow) . . . . . Proceed to couple to train on main track or siding.

Helper engine that is to move and couple to a train on main track or siding after receiving proper absolute signal indication, must stop on short track circuit, just east of 3-unit absolute signal, and wait for "call-on" signal to operate. When "call-on" signal displays a flashing yellow, it confers authority to pass the 3-unit absolute signal indicating "stop," and move to the train occupying the main track or siding after such train has stopped and hand signal is received from member of train crew.

Telephone for communicating with train dispatcher located at:

Signal 2596, 2597, 2721, 2828, 2829, 2837, 2838, 2868, 2869, 2882, 2883.

**GENERAL REGULATIONS**

**RULE 825.** Instructions for setting hand brakes:

Dunsmuir and Dunsmuir Yard:

- Passenger trains . . . . . Two brakes on east end, Three brakes on west end.
- Freight trains or cuts of 25 cars or less . . . . . Ten brakes on west end.
- Freight trains or cuts of 26 to 50 cars . . . . . Ten brakes on west end, Five brakes on east end.
- Freight trains or cuts of over 50 cars . . . . . Ten brakes on west end, Ten brakes on east end.

Employee releasing any of these brakes must set an equal number to replace them, except when preparing train for departure. Staff brakes on freight trains must be set with the assistance of a brake club after train has stopped.

**Dunsmuir Yard:** Hand brakes will not be set on freight trains if outgoing crew takes charge of train on arrival unless engine is detached.

**Dunsmuir:** Hand brakes will not be set on passenger trains standing at the station unless engine is detached provided conductor has reached understanding that engineer will remain on engine at all times and control train by use of air brakes.

Portable rail skids are hung on posts at lower end of sidings at Central Valley, Gray Rocks, Lakehead, Delta, Lamoine, Gibson, Sims, Conant and Castle Crag.

When necessary to leave cars on these tracks, permission must first be obtained from Chief Train Dispatcher. See all Sub-Divisions, Rule 825.

**RULE 827: Gray Rocks-O'Brien:** Dragging equipment detector, MP 267.5, east of Central Valley, and MP 279.2, east of O'Brien.

Refer to Rule 827, All Subdivisions.

**AIR BRAKE RULES  
FREIGHT AND MIXED TRAINS**

**RULE 17.** Retaining valves must be used on descending grades as follows:

**Dunsmuir Yard and Delta, Middle Creek and Matheson.**

WITHOUT DYNAMIC BRAKE IN OPERATION: One retaining valve for each 80 tons in train. If gross tonnage exceeds 80 tons per operative brake, retaining valves must be used on all cars and speed must not exceed 15 MPH.

WITH DYNAMIC BRAKE IN OPERATION:

Permissible Tons Per Unit Without Retaining Valves\*

	Basic Dynamic Brake		Extended Range Dynamic Brake		
	4 Axle	6 Axle	4 Axle	6 Axle	8 Axle
With dynamic brake in operation but without pressure maintaining system of braking:					
Dunsmuir Yard and Delta	1050	1550	1300	1950	2600
Middle Creek and Matheson	525	775	650	950	1250
With dynamic brake in operation and with pressure maintaining system of braking:					
Dunsmuir Yard and Delta	1900	2850	2325	3500	4650
Middle Creek and Matheson	1500	2250	1800	2700	3600

If permissible tonnage is exceeded, one retaining valve must be used for each 150 tons in excess thereof.

Locomotive classes EF 425, EF 623, EF 625, EF 630, EF 636, GF 425 (except units 6700-6727), GF 628, GF 630, GF 633, EF 850B and GF 850 are equipped with extended range dynamic brake.

\*If any unit having basic dynamic brake is operated with units having extended range dynamic brake, all units in consist must use tonnage authorized for units having basic dynamic brake.

**RULE 24-B. Dunsmuir Yard and Dunsmuir:** Incoming engineer, after completing stop, must make a full service brake application leaving brakes applied. When outgoing crew takes charge of train on arrival or otherwise is assured, upon request, that continuity of brake pipe has not been disturbed, engineer will release brakes and proceed.

**RULE 33. Middle Creek and Matheson:** Maximum tonnage per operative brake—80 tons; except with dynamic brake and pressure maintaining system of braking in operation; with not more than 20 cars for each six axles of dynamic brake; with speed not exceeding 20 MPH, and with all retaining valves on loaded cars in high pressure position—100 tons.

Should dynamic brake failure occur while handling in excess of 80 tons per operative brake, train may proceed at speed not exceeding 15 MPH, if in judgment of conductor and engineer it is safe to do so, and provided retaining valves are used as prescribed by Air Brake Rule 17.

Restrictive grades are as follows:

Westward	MP	to	MP	MPH
Between Sims and Gibson	307.6		306.3	25
MATHESON BRANCH				
Westward	263.0		260.6	20
Eastward	264.1		265.0	20

**MISCELLANEOUS**

- Eighty-five foot tri-level flat cars, loaded or empty, must not be handled over Matheson Branch.
- Engines listed are not permitted to operate on tracks shown below:

Class of Engine	Restricted Tracks
All engines and cars	Crane spur off Koppers Company spur at MP 246.4 (west of Anderson).
All engines and cars	Gray Rocks—Beyond restriction sign on Calaveras Cement Co. Track No. 2.
All engines	Middle Creek. Over structure mp 260.87, Keswick Dam Spur.

**3. Load limit (car and contents):**

*Davis-Tehama	315,000 pounds
*Tehama-Dunsmuir	315,000 pounds
Woodland-Sugarfield	240,000 pounds
Harrington-Hamilton via Colusa	240,000 pounds
Hamilton-Wyo	281,000 pounds
Redding-Matheson	251,000 pounds
Except gondola cars, series SP 345,000 to SP 345,699	240,000 pounds

Unless authorized by Superintendent, heavier loads must not be handled.

\*Refer to All Subdivisions, page 15, Miscellaneous item No. 11

**4. LOCATION OF OVERHEAD AND SIDE STRUCTURES NOT STANDARD CLEARANCE ON MAIN TRACK AND SIDINGS**

MP	Location	Description
89.26	Yolo	Cache Creek bridge Overhead
167.72	West of Hamilton	Stony Creek bridge Side
300.00	Lamoine	Bridge on siding Side
301.80	Lamoine	Bridge No. 6 Overhead and side
302.20	Lamoine	Bridge No. 7 Overhead and side
305.30	Gibson	Bridge No. 8 Overhead and side
305.40	Gibson	Tunnel No. 13 Overhead and side
306.70	Fisher	Bridge No. 9 Overhead and side
310.60	Sims	Bridge No. 13 Overhead and side

**SPECIAL INSTRUCTIONS — WEST VALLEY SUBDIVISION**

**SPEED RESTRICTIONS FOR TRAINS:** Maximum speed of trains in territory shown below is subject to further restrictions applicable to engines in the train as shown in **SPEED RESTRICTIONS FOR ENGINES** appearing on page 14, and **MAXIMUM SPEED PERMITTED WITH CERTAIN EQUIPMENT** and **OTHER MAXIMUM SPEEDS** appearing on page 15 of Special Instructions for All Subdivisions. Speed must be further reduced as prescribed by speed signs, except as specifically authorized by Special Instructions herein, or by timetable bulletin.

All trains must run carefully during and after heavy storms, particularly when the track is apt to be affected. When fog, storms or other conditions obscure track or signals, speed of trains must be so reduced as to permit strict observance of signals and **INSURE SAFETY, REGARDLESS OF TIME.**

TERRITORY			PASSENGER TRAINS	FREIGHT	TERRITORY			PASSENGER TRAINS	FREIGHT
MP	MP	Column:	1	2	MP	MP	Column:	1	2
<b>EASTWARD, DAVIS TO DUNSMUIR</b>					<b>WESTWARD, DUNSMUIR TO DAVIS:</b>				
75.60 to 76.00	76.00 to 81.80		40	40	213.80 to 186.03	186.03 to 185.90		25	25
81.80 to 84.40	84.40 to 85.50 (Woodland)		70	55	185.90 to 178.90	178.90 to 178.00 (Corning)		35	35
85.50 to 86.02	86.02 to 149.50		65	55	178.00 to 165.70	165.70 to 165.50 (Orland)		70	55
149.50 to 150.00 (Willows)	150.00 to 165.50		40	40	165.50 to 150.00	150.00 to 149.50 (Willows)		40	40
165.50 to 165.70 (Orland)	165.70 to 178.00		70	55	149.50 to 86.02	86.02 to 85.50		70	55
178.00 to 178.90 (Corning)	178.90 to 185.90		60	55	85.50 to 84.40 (Woodland)	84.40 to 81.80		65	55
185.90 to 186.29 (Beginning of D.T.)	186.29 to 213.80		70	55	81.80 to 76.00	76.00 to 75.60		70	55
			25	25				40	40
213.80 to 214.90	214.90 to 223.18		25	25	322.57 to 295.60 (288.66)	288.66 to 285.93		25	25
223.18 to 224.39 (Red Bluff)	224.39 to 226.61		70	55	285.93 to 281.00	281.00 to 269.05		45	45
226.61 to 233.60	233.60 to 242.46		45	45	269.05 to 261.17	261.17 to 259.66		60	55
			60	55	259.66 to 258.00 (Redding)			45	45
			65	55				60	55
			70	55				45	45
242.46 to 243.74	243.74 to 247.02		65	55	258.00 to 247.27	247.27 to 247.02		70	55
247.02 to 247.27	247.27 to 258.00		70	55	247.02 to 243.74	243.74 to 242.46		60	55
258.00 to 259.66 (Redding)	259.66 to 261.17		60	55	242.46 to 233.60	233.60 to 226.61		70	55
261.17 to 269.05	269.05 to 281.00		70	55	226.61 to 224.39	224.39 to 223.18 (Red Bluff)		65	55
281.00 to 285.93	285.93 to 288.66 (295.60)		45	45	223.18 to 214.90	214.90 to 213.80		60	55
295.60 to 322.57			45	45				70	55
			25	25				25	25
<b>EASTWARD, HARRINGTON TO WYO (VIA COLUSA):</b>					<b>WESTWARD, WYO TO HARRINGTON (VIA COLUSA):</b>				
108.81 to 120.70	120.70 to 121.30 (Grimes)		...	35	180.46 to 180.24	180.24 to 171.15		...	15
121.30 to 169.98	169.98 to 170.00 (Hamilton)		...	15	171.15 to 170.50	170.50 to 170.00		...	49
170.00 to 170.50	170.50 to 171.15		...	30	170.00 to 169.98 (Hamilton)	169.98 to 121.30		...	35
171.15 to 180.24	180.24 to 180.46		...	35	121.30 to 120.70 (Grimes)	120.70 to 108.81		...	30
			...	49				...	15
			...	15				...	35
<b>EASTWARD, WOODLAND TO SUGARFIELD:</b>					<b>WESTWARD, SUGARFIELD TO WOODLAND:</b>				
85.56 to 87.70	87.70 to 88.24		...	25	88.24 to 87.70	87.70 to 85.56		...	10
			...	10				...	25
<b>MATHESON BRANCH: EASTWARD, REDDING TO MATHESON</b>					<b>MATHESON BRANCH: WESTWARD, MATHESON TO REDDING</b>				
			...	25				...	25

# SPECIAL INSTRUCTIONS — WEST VALLEY SUBDIVISION

At Woodland, Willows, Orland, Corning and Anderson when engine passes last crossing within limits of restriction in direction of movement, speed may be resumed to that shown on next speed sign.

**Between MP 75.60 and MP 185.90 and between MP 258.00 and MP 321:** Freight trains, light engines and caboose hops may operate at Column 1 speeds not exceeding 65 MPH when authorized by train order, provided train has no restricted cars and does not exceed the requirements of tons per operative brake, Miscellaneous, Item 15, Page 16, All Subdivisions.

**Between MP 214.90 and MP 258.00:** Freight trains, light engines and caboose hops may operate at Column 1 speeds not exceeding 65 MPH when authorized by train order, provided train has no restricted cars and does not exceed 80 tons per operative brake and 120 cars.

Following classes of engines must not exceed the speed shown when operating between MP 108.81 and MP 170.12 on the Clousa Branch:

EF415 and EP415 .....	20 MPH
ES410, FS412 and AS410 .....	30 MPH

SPEED RESTRICTIONS FOR OTHER THAN MAIN TRACKS	With Caution Not Exceeding MPH
Through sidings, yard and other tracks, wyes, balloon tracks, crossovers and turnouts, except: .....	15
Through turnouts on other than sidings .....	10
On Branches Not Otherwise Specified .....	10
On gravel pit tracks — Cory .....	10

### SPEED RESTRICTIONS ON SIDINGS (AND TURNOUTS)

Location	With Caution Not Exceeding MPH	Location	With Caution Not Exceeding MPH
Rawson .....	25	Mead .....	25
Blunt .....	25	Lakehead .....	25
Culp .....	25	Delta .....	20
Draper .....	25	Lamoine .....	20
Girvan .....	25	Sims .....	20
Silverthorn .....	25	Conant .....	20
Central Valley .....	25	Castle Crag .....	20
Gray Rocks .....	25		
O'Brien .....	25		

**SPECIAL INSTRUCTIONS — EAST VALLEY SUBDIVISION**

**RULE 10-J.** Speed signs placed to left of track: Westward at MP 145.88 reading 45.

**RULE 82-A.** Extra trains originating Chico and operating between Chico and Stirling City will display engine number as an extra train on entire trip, as indicated by the engine number of the lead unit leaving Chico and are authorized to operate as an extra train between Chico and Stirling City without obtaining a clearance at Chico.

Extra trains originating Yuba City and operating between Yuba City and Tudor will display the engine number of lead unit leaving Yuba City, and are authorized to operate as an extra train between Yuba City and Tudor without obtaining a clearance.

**RULE 83.** Extra trains operating on Yuba City Branch between Yuba City and Tudor, in addition to information required by train register located at Yuba City, must register destination of trip (turning point) and date of departure in the column captioned "Signals." When trip has been completed, date of arrival at Yuba City must also be entered in column captioned "Signals." Extra trains enroute to this territory must not leave Yuba City until it has been ascertained from train register that the preceding extra train via the route to be used has completed the trip and registered time and date of arrival at Yuba City accordingly.

Extra trains operating on the Stirling City Branch between Chico and Stirling City, in addition to information required by train register located at Chico, must register destination of trip (turning point) and date of departure in the column captioned "Signals." When trip has been completed, date of arrival at Chico must also be entered in column captioned "Signals." Extra trains enroute to this territory must not leave Chico until it has been ascertained from train register that the preceding extra train via the route to be used has completed the trip and registered time and date of arrival at Chico accordingly.

**RULE 83-A.** At the following stations, only the trains indicated will register:

- Roseville—All trains except extra trains consisting entirely of passenger equipment and not terminating at Roseville.
- Yuba City—Trains originating or terminating.
- Chico—Trains originating or terminating.

**RULE 93.** Yard limits in which the provisions of Rule 93 will apply except within CTC limits, are established at the following stations:

West MP		East MP
98.04	Roseville (Eastward and No. 2 Track) .....	110.87
98.04	Roseville (No. 1 and Westward Track) .....	110.87
143.78	Berg (Yuba City Branch).....	148.42
143.78	Villa Verona (Oroville Branch) .....	End of Branch
183.48	Chico (Stirling City Branch).....	189.00

**ROSEVILLE:** For train and engine movements Roseville yard, see Roseville Subdivision Rule 93.

**ROSEVILLE:** Westward trains and engines from East Valley Subdivision must not pass Signal 1063 unless proceed signal, yellow flag by day, yellow light by night, or oral authorization received from switchman. Westward trains and engines must not pass red aspect of switch point indicator adjacent to Signal 1063 unless oral authority received from switchman.

For other train and engine movements Roseville Yard, see Roseville Subdivision Rule 93.

**RULE 98.** Railroad crossings at grade not interlocked:

**Roseville:** Lead from yard to East Valley Subdivision main track crosses No. 2 Track and No. 1 Track of Roseville Subdivision near passenger station. Eastward freight trains from yard to East Valley Subdivision will be governed by Signal 1062 and westward freight trains from East Valley Subdivision to enter yard will be governed by bottom unit of Signal 1063 before fouling or moving over No. 2 Track and No. 1 Track.

**Yuba City:** SNRy at Bridge St., and at B St.—Stop within 200 feet of crossings.

**MP 186.60 on Stirling City Branch:** SNRy crossing—Stop within 200 feet of crossing. Stop signs with red reflective background have been placed at the following railroad grade crossings:

- Bridge Street—Yuba City,
- B Street—Yuba City,
- MP 186.60—Stirling City Branch.

**RULE 99.** Will not apply on Stirling City and Yuba City branches.

**RULE 99-A.** Flag protection to rear of train is not required when rear of train is standing between westward absolute signal at MP 108.16 and eastward absolute signal at MP 106.65 East Valley Subdivision.

**RULE 103-A.** Trains and engines must stop and be preceded by flag-man before crossing highways and streets at:

- Clayton.....Spur.
- Marysville.....14th and E Street crossings.

When westward absolute signal at east end Chico siding displays stop indication, trains must stop east of 8th St. crossing to avoid blocking fire route.

**RULE 104.** The normal position of rigid switches at junctions:

- Chico .....Stirling City Branch,  
for Stirling City Branch.
- Berg.....Yuba City Branch Junction Switch,  
for controlled siding.

**RULE 204.** Trains to or from East Valley Subdivision with the same conductor and engineer operating through Tehama may be issued train orders on East Valley Subdivision or West Valley Subdivision that affect their movement on either of these subdivisions.

**RULES 283 and 288. Berg:** Coupled-in-motion track scale at MP 145.47. Westward trains entering siding east end Berg may receive lunar light when absolute signal displays aspect per Rule 283, Fig. D or Rule 288, Fig. C., indicating train is to be weighed. Train to be moved through siding to east switch of scale track and lined through scale track. Speed of train when weighing must not exceed 4 MPH. A white speed indicator light located west of scale house is bidirectional, displaying indication both eastward and westward. Light is so set as to give a continuous white aspect for speeds under 4 MPH and will give a flashing white aspect for speeds in excess of 4 MPH. Movement of train over scale should be at a continuous speed of 4 MPH without slack action or stopping. While weighing a train a reverse movement must not be made. If indicator light on east side of scale house displays white light train may be weighed. If blue light displayed, crew member must push button located next to light; if indicator changes to white, train may be weighed. If it remains blue, train dispatcher must be contacted for instructions. After train is weighed and before removing tape, member of crew must observe indicator lights. If white light is displayed, power has not been interrupted while train being weighed. If blue light displayed, train dispatcher must be contacted and train reweighed.

**RULE 289.** Eastward absolute signal governing movement from Yuba City Branch equipped with lunar unit and may display aspect per Rule 289, Fig. C.

**RULE 306.** The following block signals, equipped with triangular plate displaying the letter "P," have included in their control limits some special protective device. Absolute signals are listed as "P-A."

Eastward	Protection	Westward
P-A	Collision detector, highway underpass, MP 108.22 ...	P-1099
P-A	High water detector, bridge No. 135.00 .....	P-1357
P-A	Spring switch west end siding Marysville,.....	
	Spring switch east leg wye, Binney Jct. ....	P-A
	Spring switch Yuba City Branch Jct. Switch.....	P-A
P-1906	High water detector, bridge No. 191.83 .....	P-A

**SPRING SWITCHES**

**RULE 538.** Spring switches equipped with facing point locks are located as follows:

Location	Normal Position
Binney Jct.....East leg of Wye .....	Main Track
Marysville.....West end siding .....	Main Track

Spring switches not equipped with facing point locks are located as follows:

Location	Normal Position
Stirling City.....50 feet west of balloon track switch .....	For eastward movement

Main track switch 50 feet east of spring derail at Stirling City must be left lined and locked for movement into balloon track.

**RULE 705. LETTER TYPE INDICATORS**

Indicators located as follows:

Illum. Letter	On Signal	Approaching	Authorizes and requires
S	P-A	Marysville (West switch Marysville)	Enter siding
S	A	Signal west end Berg Siding	Enter Yuba City Branch
S	P-A	Binney Jct. east leg wye	Enter east leg of wye.

**RULE 705. HOT BOX DETECTORS**

Illum.	On Signal	Approaching	Location of Readout
H	Eastward Absolute Signal E. E.	Ostrom	Westward Absolute Signal W.E. Ostrom
W	1356	Rupert Dantoni Jct.	
W	1377	Ostrom	
H	MP 138.03	Dantoni Jct.	MP 139.8 Dantoni Jct.
H	1601	Gridley	MP 158.15 Gridley
W	1628	Riceton	
H	1658	Richvale	Eastward Absolute Signal E.E. Richvale
W	1659	Riceton	
W	2044	Los Molinos	
H	2045	Vina	Westward Absolute Signal W.E. Vina
W	2071	Vina	
H	MP 208.0	Los Molinos	MP 209.8 Los Molinos

**SCANNER SITE**

MP	Type	Direction	Location
116.0	D	Westward	Lincoln
136.4	A	East and West	Ostrom-Rupert
163.9	A	East and West	Riceton
206.3	A	East and West	Vina-Los Molinos

Refer to Rule 705 All Subdivisions.

**CENTRALIZED TRAFFIC CONTROL**

**RULE 760.** Limits extend from eastward absolute signal, MP 106.65 Roseville to westward absolute signal at end of double track Tehama, MP 211.88.

To enter East Valley main track from east leg of wye, Roseville, at hand operated switch, permission for the movement must first be obtained from the train dispatcher, then line switch and be governed by indication of Signal 1068 and instructions from train dispatcher.

**Binney Jct.:** Movements across WPRR, MP 141.8 and movements onto east leg of wye are under control of SP train dispatcher. When absolute signals governing movements over crossing display

"Stop" indication, member of crew must contact train dispatcher for instructions. If signal cannot be cleared, after ascertaining from indications on control machine that there is no train approaching from either direction on WPRR, train dispatcher may authorize member of crew to operate "Push Button Time Release" in accordance with instructions posted in box marked "SP" near crossing.

Westward absolute signal located at east leg of wye is a three unit signal. Top unit governs movements on main track; middle unit to clearance point east end Marysville siding; bottom unit to east leg of wye.

Eastward absolute signal located on signal bridge at east end of Marysville siding governing movement from siding is a three unit signal. Top unit governs movements to end of CTC; middle unit through crossover to main track; bottom unit through crossover to west leg of wye.

**Operating instructions for push button time release:**

Press button until amber light is illuminated, then release.

After time release interval red light should be illuminated, indicating time release has functioned and intersecting route is clear of conflicting train movements.

If absolute signal does not then indicate proceed after time release actuated but red light is illuminated in push button box, train may proceed over intersecting railroad crossing under provisions of Rule 776 without providing flag protection on intersecting route.

If absolute signal does not display proceed indication and red light is not illuminated in push button box after time release actuated, train may proceed only as provided by Rule 663(c) and Rule 776.

Time release intervals:

Binney Junction—5 minutes, 8 sec.

**RULE 776.** When an eastward train is standing on main track west of spring switch MP 140.7 (west end Marysville siding), engines with or without cars may pass westward absolute signal MP 140.7 governing movement over spring switch displaying stop indication at restricted speed without stopping and without obtaining permission from train dispatcher to couple engines or cars to such train. Spring switch must be hand thrown for such movements.

**GENERAL REGULATIONS**

**RULE 825.** Portable rail skid is hung on post at the west end of house track at Paradise.

See Rule 825 All subdivisions.

**RULE 827.** Dragging equipment detector located at MP 149.0 Berg. See Rule 827 all subdivisions.

**AIR BRAKE RULES**

**FREIGHT AND MIXED TRAINS**

**RULE 17.** Retaining valves must be used on descending grades as follows:

Stirling City to Butte Creek:

**WITHOUT DYNAMIC BRAKE IN OPERATION:** One retaining valve for each 80 tons in train and speed must not exceed 15 MPH.

**WITH DYNAMIC BRAKE IN OPERATION:**

Permissible Tons Per Unit Without Retaining Valves\*

	Basic-Dynamic Brake		Extended Range Dynamic Brake		
	4 Axle	6 Axle	4 Axle	6 Axle	8 Axle

With dynamic brake in operation but without pressure maintaining system of braking ..... 325 475 350 550 725

With dynamic brake in operation and with pressure maintaining system of braking ..... 700 1050 800 1200 1600

If permissible tonnage is exceeded one retaining valve must be used for each 150 tons in excess thereof.

Locomotive classes EF 425, EF 623, EF 625, EF 630, EF 636, GF 425 (except units 6700-6727), GF 628, GF 630, GF 633, EF 850B and GF 850 are equipped with extended range dynamic brake.

**SPECIAL INSTRUCTIONS — EAST VALLEY SUBDIVISION**

GF 633, EF 850B and GF 850 are equipped with extended range dynamic brake.

\*If any unit having basic dynamic brake is operated with units having extended range dynamic brake, all units in consist must use tonnage authorized for units having basic dynamic brake.

**RULE 25.** Will apply to westward trains at Stirling City.

**RULE 33. Stirling City to Butte Creek:** Maximum tons per operative brake—80 tons.

Restrictive grades are as follows:

	MP	to	MP	MPH
Westward.....	215.46	.....	188.75	.....15

**MISCELLANEOUS**

1. Crossover diverging at MP 122.94 to WPRR at WPRR MP 180.42.

Hand operated switch installed at west end crossover is normally positioned for spur located at 122.83. Hand operated switch at east end crossover, normally positioned for WPRR main track, is equipped with electric lock and protected by separate hand operated derail located approximately 110 feet west of WPRR main track.

Instructions for operation electric lock located in phone box adjacent to WPRR main track switch. Electric lock switch must be operated before derail is lined, otherwise electric lock will not release. WP operating Rule 550 applies.

Eastward SP trains and engines must contact WP train dispatcher to obtain permission to operate electric lock and instructions to move Marysville to Oroville.

Westward SP trains and engines must contact WP train dispatcher for instructions to move Oroville to Marysville.

These movements governed by WPRR rules, timetable, bulletins and Special Instructions.

SNRY trains will operate on SP tracks between MP 152.20, Live Oak, and MP 178.2, Durham, being governed by SP rules, timetable-special instructions and timetable bulletins.

Hand operated switch equipped with electric lock located at SN track connection to SP main track at MP 152.20, Live Oak. Eastward SN trains and engines must contact SP train dispatcher for permission to operate electric lock. Instructions for operation of electric lock located in phone box adjacent to switch. SN trains will be governed by eastward automatic signal 1522 which may display aspects per Rules 285, Fig. D, and 290, Fig. E.

Hand operated switch to SN spur at MP 152.21 is equipped with electric lock. SN trains and engines must contact SP train dispatcher for permission to operate electric lock. Signal 1523 will govern movement from SN spur to SP main track and may display aspects per Rules 285, Fig. D, and 290, Fig. E.

Hand operated switch equipped with electric lock located at SN track connection to SP main track at MP 178.2, Durham. Westward SN trains and engines must contact SP train dispatcher for permission to operate electric lock. Sign reading DO NOT FOUL MAIN TRACK WITHOUT DISPATCHER'S PERMISSION is located on SN connection to SP main track.

2. Engines listed must not operate on tracks shown below:

Class of Engine	Restricted Tracks
All engines.....	Chico—Diamond National Co. track off east leg of wye.

Load limit (car and contents):

*Roseville-Tehama.....	315,000 pounds
Chico-Stirling City.....	240,000 pounds
Berg-Wilson .....	240,000 pounds
Dantoni Jct.-Dantoni.....	240,000 pounds
Oroville-Ville Verona .....	240,000 pounds
*Binney Jct.-Oroville (WPRR).....	263,000 pounds

Unless authorized by Superintendent, heavier loads must not be handled.

\*Refer to All Subdivisions, Page 15 Miscellaneous, Item No. 11

**3. LOCATION OF OVERHEAD AND SIDE STRUCTURES NOT STANDARD CLEARANCE ON MAIN TRACK AND SIDINGS**

MP	Location	Description
210.82	Tehama.....Sacramento River Bridge.....	Overhead



# SPECIAL INSTRUCTIONS – EAST VALLEY SUBDIVISION

**SPEED RESTRICTIONS FOR TRAINS:** Maximum speed of trains in territory shown below is subject to further restrictions applicable to engines in the train as shown in **SPEED RESTRICTIONS FOR ENGINES** appearing on page 14, and **MAXIMUM SPEED PERMITTED WITH CERTAIN EQUIPMENT** and **OTHER MAXIMUM SPEEDS** appearing on page 15 of Special Instructions for All Subdivisions. Speed must be further reduced as prescribed by speed signs, except as specifically authorized by Special Instructions herein, or by timetable bulletin.

All trains must run carefully during and after heavy storms, particularly when the track is apt to be affected. When fog, storms or other conditions obscure track or signals, speed of trains must be so reduced as to permit strict observance of signals and **INSURE SAFETY, REGARDLESS OF TIME.**

TERRITORY			PASSEN- GER TRAINS	FREIGHT	TERRITORY			PASSEN- GER TRAINS	FREIGHT
MP	MP	Column:	1	2	MP	MP	1	2	
<b>EASTWARD, ROSEVILLE TO TEHAMA:</b>					<b>WESTWARD, TEHAMA TO ROSEVILLE:</b>				
106.61 (106.57) to 106.85			15	15	211.88 to 210.82		25	25	
106.85 to 116.60			65	55	210.82 to 209.93		35	35	
116.60 to 117.17			55	55	209.93 to 184.50		70	55	
117.17 to 117.43			50	50	★184.50 to 183.80		25	25	
117.43 to 123.10			60	55	183.80 to 143.88		70	55	
123.10 to 139.05			65	55					
139.05 to 139.80			50	50	143.88 to 142.00		50	45	
139.80 to 141.95			25	25	142.00 to 141.95		45	45	
141.95 to 142.00			45	45	141.95 to 139.80		25	25	
142.00 to 143.88			50	45	139.80 to 123.10		65	55	
					123.10 to 117.43		60	55	
143.88 to 183.80			70	55	117.43 to 117.17		50	50	
★183.80 to 184.50			25	25	117.17 to 116.60		55	55	
184.50 to 209.93			70	55	116.60 to 106.85		65	55	
209.93 to 210.82			35	35	106.85 to 106.61 (106.57)		15	15	
210.82 to 211.84 (junction switch)			25	25					
<b>EASTWARD, CHICO TO STIRLING CITY:</b>					<b>WESTWARD, STIRLING CITY TO CHICO:</b>				
184.38 to 185.38			...	15	215.46 to 188.75		...	15	
★185.38 to 188.75			...	20	188.75 to 185.38		...	20	
★188.75 to 215.46			...	15	185.38 to 184.38		...	15	
<b>EASTWARD, MARYSVILLE TO OROVILLE VIA WPRR:</b>					<b>WESTWARD, OROVILLE TO MARYSVILLE VIA WPRR:</b>				
178.00 to 205.00 (WPRR)			...	#	205.00 to 178.00 (WPRR)		...	#	
<b>EASTWARD, BERG TO WILSON:</b>					<b>WESTWARD, WILSON TO BERG:</b>				
144.43 to 150.00			...	15	159.01 to 150.00		...	35	
150.00 to 159.01			...	35	150.00 to 144.43		...	15	

★When engine passes last crossing within limits of restriction in direction of movement, speed may be resumed to that shown on next speed sign.

#Speed on WPRR tracks governed by WPRR rules, timetable, special instructions and timetable bulletins.

RULE 10-J. Passenger trains may operate at speed shown in Column 1 in territory where such speed is in excess of that authorized by speed sign.

Freight trains, light engines and caboose hops may operate at Column 1 speeds not exceeding 65 MPH when authorized by train order, provided train has no restricted cars and does not exceed 80 tons per operative brake and 120 cars.

★★Following classes of engines must not exceed the speed shown when operating between MP 186.72 and MP 188.75 on the Stirling City Branch:

EF415 and EP415.....10 MPH  
BS412.....15 MPH

**SPEED RESTRICTIONS FOR OTHER THAN MAIN TRACKS**      With Caution Not Exceeding MPH

Through sidings, yard and other tracks, wyes, balloon tracks, crossovers and turnouts, except: .....	15
Through sidings and turnouts at Whitney, Brock, Ostrom, Berg, Fagan, Richvale, Chico, Anita and Vina .....	25

**SPEED RESTRICTIONS FOR OTHER THAN MAIN TRACKS**      With Caution Not Exceeding MPH

Binney Jct, through east leg of wye and interchange track connection to WPRR.....	10
Oroville, through interchange from WPRR to SP.....	10
Through turnouts on other than sidings.....	10
On branches not otherwise specified .....	10

**SPECIAL INSTRUCTIONS — ROSEVILLE SUBDIVISION**

**RULES 7-A, 10-G and 10-H.** Yellow signals and unattended red flags, red lights and green "Resume Speed" flags will be placed to the left of track between Mile Posts:

195.3 and 246.2

Mile post locations above are those shown for No. 2 Track.

**RULE 10-1.** Yellow "Proceed Prepared to Stop" signs and red "Conditional Stop" signs and green flags for westward movement on No. 2 track and for eastward movement on No. 1 track will be displayed to the right of the track between MP 195.3 and MP 208.0.

Yellow "Proceed Prepared to Stop" signs and red "Conditional Stop" signs and green flags for eastward movement on No. 2 track and westward movement on No. 1 track will be displayed to the left of track between MP 195.3 and MP 208.0.

**RULE 10-J.** Speed signs to right of track in current of traffic direction with one track intervening:

- Westward at MP 91.15 reading 10.
- Eastward at MP 106.88 reading 35.
- Eastward at MP 132.10 (Brighton) reading 40.

Speed signs to left of track with one track intervening:

Westward at MP 245.20 reading 20.

Westward speed sign at MP 245.20 is 1.10 miles instead of 2 miles from point of restriction.

Westward speed sign at MP 94.90 is 2.34 instead of 2 miles from point of restriction.

Speed signs on No. 1 Track and on No. 2 Track between MP 111.00 and MP 133.00 are to the right of track for current of traffic movement.

**RULE 14(1).** Westward trains will sound crossing whistle signal immediately after emerging from west portal of Tunnel Nos. 6 and 41, west of Eder.

**RULE 26. Roseville:** Blue signs reading "Men at Work" permanently installed on base of indicator lights at each end of car repair facility Track Nos. 1, 2 and 3. When indicator lights display blue aspect, these tracks must not be entered nor cars or cut of cars moved or coupled to nor other equipment placed so as to obstruct the view of signs or lights. When indicator lights display yellow aspect, blue sign reading "Men at Work" will not apply to these tracks.

Absence of both blue and yellow aspect in these indicators must be considered as displaying most restrictive indication and blue signs respected in accordance with this rule.

Conductor reporting for duty on outbound trains will instruct crews to immediately proceed to make-up track and be governed by the following:

Crews may release all hand brakes on their train except 7 on west end and 3 on east end on north and eastbound trains, and release all hand brakes on their trains except 7 on west end of all westbound trains. The 7 hand brakes on west end and 3 hand brakes on east end of north and eastbound trains and the 7 hand brakes on west end of westbound trains must not be released until blue flag has been removed.

**RULE 81. Sacramento:** Before entering main track at 7th or 15th Street, trains and engines except yard engines must receive proceed signal from switchman at location entry is made or movement orally authorized by yardmaster or his representative.

**RULE 82-A.** Trains to San Joaquin Division at Polk, originating at Sacramento or Roseville, must obtain two clearances, one endorsed Sacramento Division, the other endorsed San Joaquin Division. Train orders addressed to such trains at Sacramento and Roseville will apply the same as if addressed to them at Polk.

First class trains to or from San Joaquin Division at Polk will

assume the corresponding number and schedule at Polk without clearance.

Trains to Western Division at Sacramento originating at Roseville or Elvas must obtain two clearances at Roseville, one endorsed Sacramento Division, the other endorsed Western Division. Train orders addressed to such trains at Roseville will apply the same as if addressed to them at Sacramento and may leave Sacramento without a clearance.

Extra trains, except trains of passenger equipment, from Western Division passing Sacramento will not obtain clearance at Sacramento.

Train order Office Roseville is located at yard office.

Sacramento Northern trains originating at Sacramento, 19th and B Sts., or Sacramento-Yolo Port District connection to Western Division must obtain clearance at Sacramento. Train order office Sacramento is located in passenger station.

Crews on extra trains originating at Roseville and turning at Sacramento may leave Sacramento without clearance.

**RULE 83-A.** At the following stations, only the trains indicated will register:

Sacramento—Trains originating or terminating, except Extra trains passing Sacramento to or from Western Division.

Sacramento Northern trains to Western Division will register at Sacramento train order office.

Roseville—All trains except first-class trains, extra trains consisting entirely of passenger equipment and not terminating at Roseville.

Truckee—Trains originating or terminating.

Norden—Work extras originating or terminating.

Colfax—Trains originating or terminating.

**RULE 83-B.** Trains No. 5 and No. 6 may register by ticket at Sacramento.

**RULE 93.** Yard limits in which the provisions of Rule 93 will apply, except within CTC limits, are established at the following stations:

West MP		East MP
85.51	Sacramento	98.04
	" (Walnut Grove Branch)	93.09
	" (Placerville Branch)	97.00
131.60	" (Stockton line)	136.33
103.80	Citrus	105.26
	" (Fair Oaks Branch)	End of Branch
110.57	Folsom Jct. (Placerville Branch)	111.38
148.19	Placerville	End of Branch
110.64	Walnut Grove	113.90
98.04	Roseville (Eastward and No. 2 Track)	110.87
98.04	" (No. 1 and Westward Track)	110.87
119.34	Newcastle (No. 2 Track)	120.82
118.74	" (No. 1 Track)	120.15
122.66	Auburn	125.60
140.03	Colfax	142.94
169.11	Emigrant Gap	172.12
207.28	Truckee	209.09
237.49	Sparks	249.48

**Yard limit signs located to left of track:**

Approaching Truckee in both directions.

**Sacramento:** Sacramento Northern trains preparing to enter SP tracks at 19th & B, or 22nd & B Sts., must stop clear of fouling point, or derail if any, and member of crew must contact SP yardmaster for permission to enter SP tracks. Before switch is lined it must be known by observation that there is no movement closely approaching track to be occupied.

CCT trains preparing to enter SP tracks at Sacramento or Polk must stop clear of fouling point or derail, if any. Member of crew

must contact SP operator at Elvas for permission to enter SP tracks at Polk. To enter SP tracks at 22nd St., crew member must contact SP yardmaster. Before switch is lined it must be known by observation that there is no movement closely approaching track to be occupied. When CCT trains clear SP tracks at 22nd St. member of crew must advise SP yardmaster.

**Antelope:** Switchman's proceed signal, green and white flag by day, green and white light by night, will be an indication that protection has been provided for movement against current of traffic within yard limits on eastward main track.

**Roseville:** End of double track at MP 103.14 Antelope, and at MP 106.16 Roseville. Single track between MP 103.14 and MP 106.16 is within interlocking limits.

Flashing white light installed west of electrically operated switch on Tracks 21-25. Eastward movements, except yard engines, must not be made from Track 21 unless switch is lined and flashing white light is displayed or movement is orally authorized.

Westward freight trains and engines from Roseville Subdivision, after receiving proceed signal or oral authorization from switchman, may pass Signal 1065 displaying stop indication without stopping when movement to be made into yard tracks.

Westward freight trains and engines, except yard engines, or trains consisting entirely of passenger equipment, when making continuous movement on main track must not pass Signal 1065 unless proceed signal or oral authorization received from switchman.

Westward freight trains and engines from Roseville Subdivision must stop clear of Berry St. crossing, MP 107.20 unless flashing yellow light is displayed in special signal just west of Berry St.

Westward trains and engines (except yard engines) using running track must not pass fouling point at west end in vicinity of Dry Creek unless proceed signal received from switchman, yellow flag by day, yellow light by night, or oral authorization or signal received from trainman of the same crew.

Eastward trains entering yard track must not pass Antelope train order-office unless proceed signal or oral authorization received from switchman.

Westward trains and engines (except yard engines) using running track at Antelope must not pass fouling point unless proceed signal received from switchman, green flag by day, green light by night, or oral authorization or signal received from trainman of the same crew.

Eastward trains leaving via drill track must not pass Signal 1072 displaying stop indication without contacting switchman orally.

Eastward freight trains leaving via No. 2 Track must not pass Signal 1074 displaying stop indication without contacting switchman orally.

Movement of trains in both directions between eastward Signals 1060 and 1064 and westward Signals 1065 and 1067 on Roseville Subdivision and between eastward Signals 1062 and 1064 and westward Signal 1063 on East Valley Subdivision will be governed by signal indication which will supersede the superiority of trains, but movements must be made with caution, and only after block signal indicating proceed is displayed as prescribed below:

For eastward movement on No. 1 Track, top unit on Signal 1064 governs movement to No. 1 Track; bottom unit governs movement to East Valley Subdivision.

Eastward movement on No. 2 Track is governed by Signal 1060.

For westward movement on No. 1 Track; top unit on Signal 1065 governs movement to No. 1 Track; bottom unit governs movement through crossover to No. 2 Track.

For westward movement on East Valley Subdivision, top unit on Signal 1063 governs movement to junction switch leading to No. 1 Track; bottom unit governs movement across No. 1 Track and No. 2 Track of Roseville Subdivision to yard tracks.

Signal 1062 on east drill track governs movement to East Valley Subdivision only.

Trains stopped by Signals 1060, 1062, 1063, 1064, 1065 or 1067 must not proceed until signal displays proceed indication, except may proceed after stopping if proceed signal or oral authorization received from switchman, movement to be made with caution.

**DIESEL SERVICING FACILITIES:**

Westward movement must not be made over power operated switches on inbound lead unless movement is orally authorized by yardmaster or his representative.

Tracks 3 to 5 inclusive are equipped with electro-pneumatic controlled switches and switch point indicators. Indicators do not indicate track occupancy, but will display green aspect when switch is in normal position and yellow aspect when switch is in reverse position. When indicator light is not lighted, careful examination of switch must be made before making movement over switch.

Service Lead from Subway to oil, sandhouse and diesel facilities has stop sign located at fouling point of inbound lead to receiving tracks. After stopping it will be permissible to proceed if route is clear.

Switch position indicator located at:

Roseville.....Switch in westward running track.

Indicator does not indicate track occupancy but when displaying red, yellow or green aspects following will govern:

- Red aspect . . . . Inoperative.
- Yellow aspect. . . Switch lined for yard receiving unit.
- Green aspect . . . Switch lined for running track Antelope.

Stop signs with reflective background are located on eastward yard running Track No. 21 between Antelope and Roseville. Instructions governing movement past each sign as follows:

**West of Dry Creek Subway.  
East end Track No. 21.**

**STOP UNLESS PROCEED SIGNAL RECEIVED FROM SWITCHMAN OR ORALLY AUTHORIZED BY YARDMASTER OR HIS REPRESENTATIVE.**

These signals will not be considered a red flag as prescribed by Rule 10-G. Yard engines accompanied by yard crews may pass these signals without stopping.

**Hump Movements:**

Light signals which govern hump movements located as follows:

- South Hump . . . . . At crest to right of track.
- North Hump . . . . . At crest to left of track.

Light signals which repeat the aspect of hump signals located as follows:

- South Hump . . . . . To left of south lead track, west of manual crossover.
- North Hump . . . . . To left of north lead track, west of manual crossover.

When crossovers west of crest are lined normal, the south hump repeater will repeat the aspect of the south hump signal, and the north hump repeater will repeat the aspect of the north hump signal.

When crossover west of crest is lined for movement from south receiving tracks to north hump, the south hump repeater signal will repeat the aspect of the north hump signal.

When crossover of crest is lined for movement from north receiving tracks to south hump, the north hump repeater signal will repeat the south hump signal.

These light signals do not indicate track occupancy or position of switches, but when displaying red, flashing red, yellow or green aspect, following will govern:

Aspect	Indication
Red . . . . .	Stop
Flashing Red . . . . .	Back
Yellow . . . . .	Proceed at normal hump speed
Green . . . . .	Proceed

For eastward movement of cars from receiving yard to crest, hump and repeater signals must display yellow or green aspect and in addition engineer instructed to move either orally or by hand or lamp signals by yardmaster or his representative in charge of movement.

Movement of cars toward crest of hump must not be made past repeater signal displaying red aspect unless engineer is orally in-

## SPECIAL INSTRUCTIONS—ROSEVILLE SUBDIVISION

formed by yardmaster or his representative that protection has been provided to safeguard the movement. Yardmaster before authorizing such a movement must know that crossovers west of crest are properly lined for such a movement and that humping movements from opposite hump through diamond crossover east of crest are stopped.

Movement of cars toward crest of hump when repeater signal displays red aspect may be authorized by yardmaster or his representative as far as the lead carman's tower.

Light signals which govern trim movements from bowl are located as follows:

South Hump . . . . . At crest to left of track.  
North Hump . . . . . At crest to right of track.

Light signals which repeat the aspect of the trim signals are located as follows:

South Hump . . . . . No. 1 repeater to left of track near 22-49 Switch Tower A-B.  
No. 2 repeater between leads at 36-42 and 43-46 Switches.  
North Hump . . . . . No. 1 repeater to right of track near Switch 1-21.  
No. 2 repeater to right of track near Switch 1-7.

These light signals do not indicate track occupancy or position of switches but when displaying red or yellow aspect, following will govern:

Aspect	Indication
Red . . . . .	Stop
Yellow . . . . .	Proceed

For westward movement from bowl tracks to crest, trim and repeater signals must display a yellow aspect, and in addition engineer instructed to move either orally or by hand or lamp signals by switchman in charge of movement. Movement must not be made west of fouling point of bowl tracks when trim and repeater signals display red aspect unless engineer is orally informed by yardmaster or his representative that movement is protected. Yardmaster authorizing such movement must insure that any conflicting movements are stopped.

Switch point indicators are provided on all power operated switches at west end of bowl. Westward movement must not be made to foul lead or any track diverging from lead unless switch is seen to be lined for the movement.

Tracks 23, 24 and 25 equipped with electrically controlled switches and switch point indicators. Indicators do not indicate track occupancy, but will display green aspect when switch is in normal position and yellow aspect when switch is in reverse position. When indicator lamp is not lighted, switch points must be checked to determine proper position before making movement over switch.

Trains or engines, except yard engines, must not enter tracks 23, 24 or 25 unless a proceed signal is received, green flag by day, green light by night, or engineer is orally authorized. When proceed signal received, or orally authorized, train or engine may proceed into track lined for movement.

Eastward movements from tracks 23, 24 and 25 are governed by indicator light located adjacent to No. 23 track switch.

Eastward movements, except yard engines, must not be made from tracks 23, 24 or 25 unless switches are lined and flashing white light is displayed or movement is orally authorized.

Westward movements, except yard engines, must not be made from tracks 23, 24 or 25 unless proceed signal received, green flag by day, green light by night or orally authorized.

Flashing white light located west of electrically operated switch on Tracks 21-25. Eastward movements, except yard engines, must not be made from Track 21 unless switch is lined and flashing white light is displayed or movement is orally authorized.

**RULE D-97.** Applies between Oakland (16th St.) and Sparks.

**RULE 98.** Railroad crossings at grade not interlocked:

**Sacramento:** WPRR at Front and R Sts.—Trains and engines must approach with caution expecting to find crossing occupied. Switching and industry tracks in vicinity of Front and R Sts.—Ascertain that each crossing is clear before using.

SNRy at Front and R Sts.—Stop within 200 feet of crossing. SNRy at Alhambra Blvd. and R Street—Stop before crossing. Stop signs with reflective background have been placed at the following railroad grade crossings:

Front and R Streets . . . . . SNRy.  
Alhambra Blvd. and R Street . . . . . SNRy.

**Roseville:** Lead from yard to East Valley Subdivision main track crosses No. 2 Track and No. 1 Track of Roseville Subdivision near station sign. Eastward freight trains from yard to East Valley Subdivision will be governed by Signal 1062, and westward freight trains from East Valley Subdivision to enter yard will be governed by bottom unit of Signal 1063 before fouling or moving over No. 2 Track and No. 1 Track.

**RULE 99-C.** Will apply on Placerville and Walnut Grove Branches.

**RULE 103-A.** Trains and engines must stop and be preceded by flagman before crossing highways at:

Sacramento: Spur track No. 130 crossing 23rd Street.  
Isleton: On wharf spur.

Cantilever flashing light signals in service at Walnut Grove Branch and Capitol Avenue crossing at Sacramento: Light type indicators located adjacent to crossing govern movement of trains and engines over Capitol Avenue. Green aspect indicates crossing gates and flashers have been actuated and movement may be made with caution. Red or dark aspect indicates stop.

Antelope: Crossing gate key control installed at "U" Street to actuate gates when backup movements made from westward main track.

Eastward trains stopping at Roseville within 400 feet of Yosemite Street crossing, when starting must not exceed 10 MPH until engine enters crossing.

Westward trains stopping at Truckee must stop with engine east of signal 2083 to avoid unnecessary operation of automatic warning device at Bridge Street.

**RULE 104.** The normal position of rigid switches at junctions: Citrus—Fair Oaks Branch, for Placerville Branch. Folsom Junction—Folsom Branch, for Placerville Branch.

**RULE 107. Roseville:** Westward trains must not pass Yosemite Street when eastward passenger train is doing work at the station, unless proceed signal received from yardmaster or his representative, green flag by day, green light by night.

**RULE 221.** Train-order office at Roseville is located at yard office. First class trains and trains consisting entirely of passenger equipment not terminating at Roseville are not required to obtain a clearance at Roseville.

Norden: Train-order signal located to the right of No. 2 track will apply to eastbound trains on No. 2 track only.

Train-order signal installed to the left of No. 1 track will apply to eastbound trains on No. 1 track only.

**RULE D-251.** Applies to the following tracks: Both tracks between Oakland (16th St.) (Western Division) to Sparks.

Eastward trains leaving Roseville, except first class, must not leave unless proceed signal (green flag by day, green light by night) or oral authority received from switchman. Will not apply to eastward extra trains consisting exclusively of passenger equipment on continuous main track movement through Roseville.

**RULE 306.** The following block signals, equipped with triangular plate displaying the letter "P," have included in their control limits some special protective device. Interlocking signals are listed as "P-I."

Eastward Signal	Protection	Westward Signal
	*Spring switch, Sacto-Yolo Port Dist. conn. . . . .	P-I
	Spring switch, end double track, MP 103.14, Antelope . . . . .	P-I
P-994	Collision Barricade Detector, MP 99.9 . . . . .	P-1009
P-1228	Slide Detector Fence, Tunnel 20, MP 123.15 to 123.39 . . . . .	
	Collision Barricade Detector, MP 124.7 . . . . .	P-1251
P-1242	Collision detector, highway underpass, MP 125.53 . . . . .	
	Collision detector, highway underpass, MP 133.35 . . . . .	P-1347
P-1374	Collision detector, highway underpass, MP 137.68 . . . . .	
P-1438	Slide Detector Fence, MP 144.46 to 144.66	
P-1508	Slide Detector Fence, MP 150.83 . . . . .	P-1515
P-1556	Slide Detector Fence, MP 156.32 to MP 156.38 . . . . .	P-1573
P-1582	Slide Detector Fence, MP 159.43 to MP 159.46 . . . . .	P-1611
P-I	Slide Detector Fence, MP 195.60 to MP 195.70, No. 1 Track . . . . .	P-1963
P-2220	Slide Detector Fence, MP 222.16 to MP 222.34 . . . . .	
	Slide Detector Fences, MP 223.87 to MP 223.80 . . . . .	P-2239
	MP 222.88 to MP 222.77 . . . . .	
	MP 222.34 to MP 222.16 . . . . .	
P-2240	Slide Detector Fence, MP 224.50 to MP 223.80 . . . . .	P-2259

\*If point indicator displays green aspect movement to Port District may proceed at restricted speed without hand throwing spring switch.

**AUTOMATIC BLOCK SIGNAL SYSTEM**

**RULE 505.** Trains or engines making westward movement to Sacramento-Yolo Port District must stop at westward signal 889, 2nd & H Sts. and contact interlocking operator Sacramento River Drawbridge, for permission to move against current of traffic to Sacramento-Yolo Port District.

Push button and pilot light are installed in box near signals 887 and 889 and near 7th St. herder shanty. Signal 887 or 889 may be cleared by operation of push button bearing number of signal from location near signal or from 7th St. herder shanty to allow bypass movement. Trains or engines encountering stop indication displayed by Signal 887 on westward freight lead must contact yardmaster, Sacramento Tower, for instructions. Yardmaster's instructions do not relieve crew desiring to enter westward main track from compliance with Rule 513.

**RULE D-506. Floriston:** Light type indicator at MP 222.40 applies to No. 1 Track only, and indicates condition of slide detector fence only and is not connected with block signal circuit. Lunar light indicates track at slide detector fence safe for trains; red aspect requires that inspection must be made of track protected by slide detector fence before train passes the fence.

**RULE 535. SPRING SWITCHES**

Spring switches equipped with facing point locks are located as follows:

Location	Normal Position
Antelope . . . . .	End of double track (MP 103.14). . . . . Westward Track

Spring switches not equipped with facing point locks are located as follows:

Location	Normal Position
*Sacramento . . . Sacto-Yolo Port Conn. . . . .	Sacto-Yolo Port Dist.
*Sacramento . . . Westward freight lead 2nd & H . . . . .	Westward main track
*Roseville . . . . East and east drill track . . . . .	No. 2 Track
Roseville . . . . East end Big Reno . . . . .	East drill track
*Gold Run . . . . East end eastward siding . . . . .	No. 2 Track

\*Equipped with switch-point indicator.

**RULE 605. INTERLOCKING**

**Sacramento River Drawbridge:** Telephones are located adjacent to interlocking signals and Signals 887 and 889.

**Nineteenth Street, Sacramento:** At crossing of R Street Track with WPRR.

Movements across WPRR main track are under control of WPRR train dispatcher located at Sacramento who will control signals which govern movement but do not indicate occupancy of track.

Signal at 19th Street will display proceed indication only when hand operated switches are lined for R Street line. When movements are to be made into Valley Grocery spur or Bekins spur, switches shall be lined for spur after entering interlocking limits. When signals governing movement over WPRR crossing display stop indication after approach circuit is occupied or if signals governing movement out of Valley Grocery spur or Bekins spur do not display proceed indication after switch has been lined, a member of crew must contact WPRR train dispatcher by telephone for instructions. Upon receiving permission from WPRR train dispatcher movement must be made under provisions of Rule 663.

Telephones located in telephone boxes at following locations:  
West leg of WPRR wye track and R Street.  
Bekins spur signal, steel relay shelter just south of crossing.

**Elvas:** Limits extend on Sacramento-Roseville line from interlocking signal 1800 feet west of tower to interlocking signal, 1370 feet east of tower, and on Elvas-Polk line to interlocking signal at west switch Polk; and on Placerville Branch to interlocking signal 600 feet east of junction switch.

Following switches are equipped with electric switch locks and must not be operated until permission has been obtained from operator whose instructions will govern movements not controlled by signal indicator:

- Elvas . . . . . American Can Co. Spur.
- Elvas . . . . . Crossover between center siding and westward track.
- Elvas . . . . . Crossover from center siding to eastward track.
- Elvas . . . . . West end of center siding.
- Hopfen spur . . . . . Switch.
- R Street industrial track . . . . . Switch.
- Black Diamond Lumber Co. . . . . Switch.

Switches will not be lined for movement to Polk siding without first obtaining permission from operator.

**Georgiana Slough Drawbridge:** At MP 119.53 on Walnut Grove Branch.

**Roseville:** Limits as follows:

- On main tracks between MP 102.50 and MP 106.64.
- Eastward signal at MP 102.50 governs movements as follows:  
Top unit to Eastward Track,  
Middle unit to receiving track through first switch,  
Bottom unit to receiving track through second switch.
- Eastward signal at MP 106.16 governs movement as follows:  
Top unit to No. 2 Track,  
Bottom unit to No. 1 Track.

Telephones to operator are located at main track signals. Instructions for operation of dual control switch machines are posted in telephone booths.

Switch to Los Angeles By-Product spur, Antelope, equipped with electric switch lock. Switch lock must not be operated until permission obtained from operator whose instructions will govern movements not controlled by signal indicator.

**Norden:** Limits extend on No. 1 Track and No. 2 Track from interlocking signals located on west end highway overpass Emigrant Gap, MP 171.87, to westward interlocking signals located on signal bridge MP 207.64, west end Truckee.

Run-around track and Turntable Lead 3—Trains or engines must obtain permission from operator before lining switch to siding. Westward interlocking signal on No. 1 Track, 550 feet east of

**SPECIAL INSTRUCTIONS — ROSEVILLE SUBDIVISION**

Norden station building connected with repeater signal on the left side of track for better visibility.

Call-on signals on certain interlocking signal masts are normally dark, but when displaying flashing yellow light are authority to pass interlocking signal displaying stop indication without obtaining permission from operator to couple to train or engine; movement to be made at restricted speed.

Bottom unit of interlocking signals for movements on siding may display lunar aspect. When lunar aspect is displayed, train or engine may proceed without stopping at restricted speed (Rule 289).

Following switches equipped with electric switch locks:

1. Summit. Spur switch MP 193.4.
2. No. 1 Turntable Lead switch, No. 1 Track.

Lock box doors on electric switch locks must not be opened without permission of operator.

**RULE 663. ROSEVILLE:** Engines, after stopping, may pass westward interlocking signals at MP 106.64 to couple to train upon receipt of hand signal by herder, green flag by day, green light by night, or after being orally authorized.

**RULE 705. LETTER TYPE INDICATORS**

Indicators located as follows:

Sacramento: Wait indicators located east and west end "R" Street overpass near Front Street.

1. Eastward and westward trains must stop at "W" indicator.
- \*2. Operation of pushbutton will extinguish "W" indicator and flashing white light will authorize movement over structure to opposing "W" indicator.
3. After receiving flashing white light and movement over structure is not made, cancel button is provided.
4. Should "W" indicator be found extinguished or flashing white light cannot be activated by operation of pushbutton, movements must be made with caution protecting against opposing trains.

\*Pushbutton box located on case of "W" indicator. Advance pushbutton provided east of Third Street for westward movements to minimize blocking Third Street crossing.

**EASTWARD**

Illum. Letter	On Signal	Approaching	Authorizes and requires movement as follows:
S	1404	Colfax	Enter siding and contact train dispatcher.
W	1688	*Emigrant Gap	When letter W is illuminated, train must stop and not proceed until indicator is extinguished.
P	7-ft. Mast MP 241.69	Reno	Eastward trains and engines must stop west of Keystone Avenue, Reno, MP 242.11, unless indicator light unit mounted on mast, MP 241.69, displays letter "P" or authority is obtained from the Yardmaster and his instructions followed.

\*When eastward train finds Signal 1688 displaying stop indication and W letter type indicator not illuminated, member of train crew must contact operator, Norden, before proceeding, and be governed by his instructions.

**WESTWARD**

S	2091	Truckee	Enter westward siding and contact operator, Norden.
W	2027	Andover*	
W	2029	Andover*	
W	2083	Truckee*	

\*When letter W is illuminated, train must stop and not proceed until indicator is extinguished.

When westward train finds Signal 2029, 2027 or 2083 displaying stop indication and W letter type indicator not illuminated, member of train crew must contact operator Norden before proceeding, and be governed by his instructions.

**RULE 705. HOT BOX DETECTORS**

Illum. Letter	On Signal	Approaching	Location of Readout
H	1421	Colfax	West End Colfax MP 141.55
W	1431	Colfax*	

**SCANNER SITE**

MP	Type	Direction	Location
98.3	D	Eastward	Planehaven
110.2	D	Westward	Rocklin
148.6	C	Eastward	Magra
143.5	A	Westward	Colfax-Cape Horn
240.0	D	Eastward	West Reno

Refer to Rule 705 All Subdivisions.

\*When letter "W" is illuminated, train must stop. Member of train crew must contact train dispatcher before proceeding and be governed by his instructions.

**GENERAL REGULATIONS**

**RULE 825. Sacramento:** Not less than three hand brakes must be set on west end of cars or trains on Tracks 2 through 9, incl. Not less than two hand brakes must be set on east end of cars or trains on Tracks 14 through 27, incl.

**Roseville:** Not less than seven hand brakes must be set on cars or trains on the following tracks Roseville Terminal:

- East End—Tracks 1 through 25, incl., Receiving Yard.
- West End—Tracks 50 through 84, incl., Departure Yard.
- West End—Track 21, Departure Yard.
- East End—All tracks in PFE repair yard, incl., Tracks 90 and 91.

Portable rail skids are hung on posts at the following locations:

- West end team track, Placerville,
- West end of interchange tracks, Placerville,
- Lower end of sidings at Bowman, Midas, Emigrant Gap Crossover Verdi.

See Rule 825—All Subdivisions.

Seven hand brakes must be secured on west end and 3 hand brakes must be secured on east end of all eastward trains arriving in Roseville departure yard.

**RULE 827. Derailment Detectors:**

Location	Signal	Protects	On Track
Mile Post	110.2	Eastward-Westward	#1
At Signal	1168	Eastward-Westward	#2
At Signal	1187	Eastward-Westward	#1
At Signal	1214	Eastward-Westward	#2
At Signal	1258	Eastward-Westward	#2
At Signal	1277	Eastward-Westward	#1
Mile Post	131.2	Eastward-Westward	#1
At Signal	1374	Eastward-Westward	#2
At Signal	1452	Eastward-Westward	#2
Mile Post	W.B. 145.6	Eastward-Westward	#1
Mile Post	E.B. 150.0	Eastward-Westward	#2
Mile Post	W.B. 150.4	Eastward-Westward	#1
At Signal	1546	Eastward-Westward	#2
Mile Post	W.B. 155.1	Eastward-Westward	#1
At Signal	1582	Eastward-Westward	#2
At Signal	1591	Eastward-Westward	#1
At Signal	1630	Eastward-Westward	#2
At Signal	1635	Eastward-Westward	#1
At Signal	1668	Eastward-Westward	#2
At Signal	1687	Eastward-Westward	#1
On Signal	1756	Eastward-Westward	#2
On Signal	1757	Eastward-Westward	#1
On Signal	1823	Eastward-Westward	#1
On Signal	1824	Eastward-Westward	#2
On Signal	1900	Eastward-Westward	#2

# SPECIAL INSTRUCTIONS — ROSEVILLE SUBDIVISION

Location	Signal	Protects	On Track
On Signal.....	1901.....	Eastward-Westward	#1
At Signal.....	1941.....	Eastward-Westward	#1
Mile Post.....	195.0.....	Eastward-Westward	#1
At Signal.....	1958.....	Eastward-Westward	#1
Mile Post.....	195.3.....	Eastward-Westward	#2
On Signal.....	2023.....	Eastward-Westward	#1
On Signal.....	2024.....	Eastward-Westward	#2
On Signal.....	2039.....	Eastward-Westward	#1
On Signal.....	2040.....	Eastward-Westward	#2
On Signal.....	2124.....	Eastward-Westward	#2
On Signal.....	2125.....	Eastward-Westward	#1
On Signal.....	2180.....	Eastward-Westward	#2
On Signal.....	2201.....	Eastward-Westward	#1
At Signal.....	2239.....	Eastward-Westward	#1
At Signal.....	2280.....	Eastward-Westward	#2
At Signal.....	2350.....	Eastward-Westward	#2
At Signal.....	2351.....	Eastward-Westward	#1
Mile Post.....	240.0.....	Eastward-Westward	#2
Mile Post.....	240.0.....	Eastward-Westward	#1

Refer to Rule 827, All Subdivisions.

**RULE 872.** Enginemen taking charge of road engines at Roseville diesel facility and enginemen taking charge of engines at Sacramento and Sparks will consider engines as having been amply supplied with water, fuel, sand and other supplies.

### AIR BRAKE RULES

#### PASSENGER TRAINS

**RULE 17.**

**Norden to Truckee-Norden to Loomis**

Without dynamic brake in operation turn up all accessible retaining valves.

#### FREIGHT TRAINS

Retaining valves must be used on descending grades as follows:

**Norden to Truckee-Norden to Loomis**

MP 131.70 to MP 123.00 (Placerville Branch).

**WITHOUT DYNAMIC BRAKE IN OPERATION:**

One retaining valve for each 80 tons in train. If gross tonnage exceeds 80 tons per operative brake, retaining valves must be used on all cars and speed must not exceed 15 MPH.

**WITH DYNAMIC BRAKE IN OPERATION:**

Permissible Tons Per Unit Without Retaining Valves\*

	Basic-Dynamic Brake		Extended Range Dynamic Brake		
	4 Axle	6 Axle	4 Axle	6 Axle	8 Axle

With dynamic brake in operation but WITHOUT pressure maintaining system of braking:

Norden to Truckee	650	950	800	1200	1600
Norden to Loomis	450	650	550	850	1125
MP 131.70 to MP 123.00 (Placerville Branch)	600	900	725	1075	1450

With dynamic brake in operation and WITH pressure maintaining system of braking:

Norden to Truckee	1800	2700	2300	3500	4600
Norden to Loomis	1400	2100	1700	2600	3400
MP 131.70 to MP 123.00 (Placerville Branch)	1500	2250	1800	2700	3600

If permissible tonnage is exceeded, one retaining valve must be used for each 150 tons in excess thereof.

Locomotive classes, EF 425, EF 623, EF 625, EF 630, EF 636, GF 425 (except units 6700-6727), GF 628, GF 630, GF 633, EF 850B and GF 850 are equipped with extended range dynamic brake.

\*If any unit having basic dynamic brake is operated with units having extended range dynamic brake, all units in consist must use tonnage authorized for units having basic dynamic brake.

**RULE 17-A.** Freight trains without dynamic brakes in operation will stop at the following stations for at least 10 minutes for wheel heat radiation.

Eastward	Westward
MP 203.0	Troy
	Emigrant Gap
	Midas
	Gold Run
	Bowman

Train inspection must be made as prescribed by Rule 827 at all wheel heat radiation stops.

**RULE 24-B. ROSEVILLE:** Engineer on incoming bypass trains, after completing stop, must make a full service brake application leaving brakes applied. When outgoing crew takes charge of train on arrival or otherwise is assured, upon request, that continuity of brake pipe has not been disturbed, engineer will release brakes and proceed.

**RULE 24-E.** Will apply to trains arriving Roseville.

**RULE 25.** Will apply at Norden when not required to stop and make train air brake tests at that point for other reasons except:

When running test is made at Crystal Lake eastward or approaching MP 209.2 westward.

Westward Freight trains: Conductor must contact engineer immediately after caboose leaves portal of Tunnel 6 or 41 and before reaching station at Norden and comply with addition to Rule 25, under All Subdivisions.

Eastward Freight Trains: Conductor must contact engineer immediately after engine passes station at Norden and before engine enters west portal of Tunnel 6 or 41 and comply with addition to Rule 25, under All Subdivisions.

**RULE 33. Norden to Truckee, Boca to Floriston, Verdi to Lawton, Norden to Rocklin.**

MP 131.70 to MP 123.00 (Placerville Branch)

**MAXIMUM TONS PER OPERATIVE BRAKE.....80 TONS**  
Restrictive grades are as follows:

Eastward	MP TO MP		MPH
Norden to Truckee	192.8	210.0	20
Boca to Floriston	219.0	224.0	25
Verdi to Lawton	229.5	240.0	25
<b>Westward</b>			
Norden to Colfax	193.6	143.6	20
West of Colfax	142.0	138.3	25
West of Colfax to East of Loomis	136.5	115.0	20
East of Loomis to Rocklin	115.0	111.3	25
<b>Placerville Branch</b>			
Westward	150.0	122.0	20
	117.5	111.7	25

**Exceptions:**

Trains with not more than 425 tons per axle of dynamic brake, pressure maintaining system of braking in operation and speed not exceeding 25 miles per hour:

**MAXIMUM TONS PER OPERATIVE BRAKE.....100 TONS**

Trains handling loaded crude oil cars only with not more than 250 tons per axle of dynamic brake, pressure maintaining system of braking in operation, not more than 90 cars and speed not exceeding 25 miles per hour:

**MAXIMUM TONS PER OPERATIVE BRAKE.....130 TONS**

Trains handling loaded crude oil cars only with not more than 300 tons per axle of dynamic brake, pressure maintaining system of braking in operation, not more than 90 cars and speed not exceeding 20 miles per hour:

**MAXIMUM TONS PER OPERATIVE BRAKE.....130 TONS**

**SPECIAL INSTRUCTIONS — ROSEVILLE SUBDIVISION**

**Norden to Truckee, Norden to Rocklin**

MP 131.70 to MP 123.00 (Placerville Branch)

Should dynamic brake failure occur while handling in excess of 80 tons per operative brake, train may proceed at speed not exceeding 15 MPH if in judgment of the conductor and engineer it is safe to do so and provided retaining valves are used as prescribed by Air Brake Rule 17.

**RULE 39.** Running test must be made on westward passenger trains just after emerging from Tunnel No. 6 or Tunnel No. 41.

**MISCELLANEOUS**

**Sacramento:**

1. Communicating signal will be used to start passenger train at Sacramento.

Excess width or height loads must not be operated on Sacramento Passenger Station Track 4. Employes must not ride on top or side of engines or cars on Track 4.

Maximum speed on Aerojet spurs, with caution, not to exceed 15 MPH, except over grade crossings 10 MPH.

2. Engines listed must not operate on tracks shown below:

Class of Engine	Restricted Tracks
All engines.....	Newcastle—Over trestle portion of fruit spurs.
All engines.....	Summit—Lumber spurs Nos. 3 and 4 beyond derail.
All engines.....	Elvas—Center siding beyond 500 feet from clear point.

3. Load limit (car and contents):

*Sacramento-Sparks .....	315,000 pounds
*Brighton-Elvas .....	315,000 pounds
Sacramento-Isleton .....	240,000 pounds
Sacramento-Brighton via R St. ....	240,000 pounds
Brighton-Placerville .....	240,000 pounds
Folsom Junction-Folsom.....	240,000 pounds
Citrus-Fair Oaks .....	240,000 pounds

Unless authorized by Superintendent, heavier loads must not be handled.

\*Refer to All Subdivisions, Page 15, Miscellaneous Item No. 11

4. Tracks between Roseville and Sparks numbered, and unless otherwise authorized, will be used as double track as follows:

- No.-1 Westward trains, via Auburn.
- No.-2 Eastward trains, via Auburn, Nevada Street.

**OPERATION OF TURNTABLES**

5. Turntable Norden equipped with rail locks each end. Before moving onto table from any lead table must be lined so engine will enter from locked end only. Engines when backing and approaching table from lead from eastward siding, will stop to clear table and member of crew after properly lining and locking table will signal engineer to move onto table by green light controlled by pushing button located on post of turntable shed on engineer's side. This signal does not indicate position of turntable or turntable lock. Engines leaving turntable will leave from locked end. In making movements to or from turntable it will not be necessary to lock opposite end of table.

Turntable must not be moved until engineer signals fireman engine is properly spotted and brakes applied.

Engineer or member of crew, preferably engineer, must remain in the cab of engine at all times when engines are being turned at Norden.

Balloon track at MP 169.16, west of Emigrant Gap, diverging from No. 1 Track. Crossover between main tracks located at east end of balloon track at MP 169.55. Engines and equipment will enter balloon track at west switch and leave balloon track at east switch.

6. Rail connection to the Yolo Port in Sacramento Yard from the clearance point at Washington to the Port Railroad connection at Riske Lane is used jointly by SNRy and SP crews. Movement on joint track governed by block signals whose indications superseded the superiority of trains.

Block indicators located at switches indicate track occupancy.

When block indicator shows block clear, switch may be reversed and movement made after block signal displays a yellow aspect.

If block indicator shows block occupied, switch must not be reversed until it has been ascertained that there is no opposing or conflicting movement.

If after switch has been reversed signal displays stop indication, train or engine must wait five minutes and then be preceded by flagman through joint track area.

Maximum speed permitted on joint track is 10 MPH and all movements must be made with caution.

Normal position of switches connecting with joint track is as follows:

SNRy Woodland Branch connection just west of West Capitol Ave. underpass lined for Yolo Port Railroad.

East wye switch SNRy Woodland Branch for movement west leg of wye.

Sacramento Yolo Port Railroad connection just east of county road crossing for SNRy west leg of wye.

Sacramento Yolo Port Railroad yard tracks are used jointly by SNRy and SP crews and all movements must be made with caution not exceeding 10 MPH.

Flag protection to the rear is not required when operating in joint track area or over Sacramento Yolo Port Railroad yard tracks.

**7. ROSEVILLE SUBDIVISION**

**LOCATION OF OVERHEAD AND SIDE STRUCTURES NOT STANDARD CLEARANCE ON MAIN TRACK AND SIDINGS**

MP	Location	Description
88.54	Sacramento .....	Sacramento River bridge .....Side and overhead
92.15	Elvas .....	American River bridge.....Side
(POLK-ELVAS)		
131.78	Polk.....	Traction company overhead crossing .....Overhead
133.13	Brighton .....	Signal bridge.....Overhead
(PLACERVILLE BRANCH)		
122.30	East of White Rock.....	Rock cut.....Side
126.40	Latrobe.....	Rock cut.....Side
126.50	East of Latrobe.....	Rock cut.....Side
128.60	East of Latrobe.....	Rock cut.....Side
(WALNUT GROVE BRANCH)		
92.41	East of Baths.....	Bridge.....Side
111.42	Snodgrass Slough.....	Bridge.....Side
(ROSEVILLE-SPARKS — EASTWARD)		
111.21	East of Rocklin.....	Antelope Creek Bridge.....Side
114.20	East of Rocklin.....	Tunnel No. 15.....Side and overhead
114.70	East of Rocklin.....	Tunnel No. 16.....Side and overhead
117.30	East of Rocklin.....	Tunnel No. 17.....Side and overhead
120.50	East of Newcastle.....	Tunnel No. 18.....Side and overhead
122.70	East of Newcastle.....	Tunnel No. 19.....Side and overhead
123.10	East of Newcastle.....	Tunnel No. 20.....Side and overhead
124.60	East of Nevada St., Auburn	Tunnel No. 21.....Side and overhead
131.20	East of Bowman.....	Tunnel No. 22.....Side and overhead
132.70	East of Bowman.....	Tunnel No. 23.....Side and overhead
132.90	East of Bowman.....	Tunnel No. 24.....Side and overhead
133.10	East of Bowman.....	Tunnel No. 25.....Side and overhead
133.30	East of Bowman.....	Tunnel No. 26.....Side and overhead
133.80	East of Bowman.....	Tunnel No. 27.....Side and overhead
134.80	East of Applegate.....	Tunnel No. 28.....Side and overhead
135.90	East of Applegate.....	Tunnel No. 29.....Side and overhead
138.70	East of Applegate.....	Tunnel No. 30.....Side and overhead
139.20	East of Applegate.....	Tunnel No. 31.....Side and overhead
139.40	East of Applegate.....	Tunnel No. 32.....Side and overhead
164.34	East of Midas.....	Tunnel No. 1.....Side and overhead
176.60	East of Emigrant Gap.....	Tunnel No. 35.....Side and overhead
176.90	East of Emigrant Gap.....	Tunnel No. 36.....Side and overhead
177.80	Crystal Lake.....	Tunnel No. 37.....Side and overhead
177.87 to 198.91	Crystal Lake to Andover ...	Snow sheds and signals in Snowsheds .....Side and overhead
180.50	East of Cisco.....	Tunnel No. 38.....Side and overhead
180.70	East of Cisco.....	Tunnel No. 39.....Overhead
185.30	East of Cisco.....	Tunnel No. 40.....Side and overhead
193.30	East of Norden.....	Tunnel No. 41.....Side and overhead
200.10	East of Shed 47.....	Tunnel No. 42.....Side and overhead
180.38	East of Cisco.....	Signal Bridge No. 1804.....Overhead
182.38	East of Cisco.....	Signal Bridge No. 1824.....Overhead
184.02	East of Cisco.....	Signal Bridge No. 1844.....Overhead
188.03	East of Troy .....	Signal Bridge No. 1880.....Overhead
189.88	East of Troy .....	Signal Bridge No. 1900.....Overhead
191.75	Norden.....	Signal Bridge No. 1919.....Overhead
201.28	East of Andover.....	Signal Bridge.....Overhead
209.12	East of Truckee.....	Signal Bridge No. 2096.....Overhead
210.60	East of Truckee.....	Signal Bridge No. 2106...Side and overhead
212.63	East of Truckee.....	Signal Bridge No. 2124...Side and overhead



# SPECIAL INSTRUCTIONS — ROSEVILLE SUBDIVISION

MP	Location	Description
214.71	East of Truckee.....	Signal Bridge No. 2146 ...Side and overhead
218.05	East of Boca.....	Signal Bridge No. 2180.....Side
220.03	East of Boca.....	Signal Bridge No. 2200 ...Side and overhead
221.88	East of Boca.....	Signal Bridge No. 2220 ...Side and overhead
230.12	East of Floriston.....	Signal Bridge No. 2300.....Overhead
231.50	Verdi.....	Signal Bridge No. 2316 ...Side and overhead
237.02	Lawton.....	Signal Bridge No. 2370.....Overhead
238.90	East of Lawton.....	Signal Bridge No. 2390.....Side
<b>(SPARKS-ROSEVILLE — WESTWARD)</b>		
238.90	West of Reno.....	Signal Bridge No. 2389.....Side
231.50	Verdi.....	Signal Bridge No. 2317 ...Side and overhead
230.12	West of Verdi.....	Signal Bridge No. 2301.....Overhead
229.65	West of Verdi.....	3rd Truckee River Crossing.....Side
221.88	West of Floriston.....	Signal Bridge No. 2219.....Overhead
220.65	West of Floriston.....	1st Truckee River Crossing.....Side
220.03	West of Floriston.....	Signal Bridge No. 2201.....Side
218.26	West of Floriston.....	Highway Bridge.....Overhead
218.05	West of Floriston.....	Signal Bridge No. 2181.....Side
214.71	West of Boca.....	Signal Bridge No. 2147 ...Side and overhead
212.63	West of Boca.....	Signal Bridge No. 2125 ...Side and overhead
212.25	West of Boca.....	Highway Bridge.....Overhead
210.60	West of Boca.....	Signal Bridge No. 2107.....Overhead
209.12	West of Boca.....	Signal Bridge No. 2109.....Overhead
207.55	West of Truckee.....	Signal Bridge No. 2075.....Overhead
200.22	Andover.....	Tunnel No. 13.....Side and overhead
198.91 to 177.87	Andover to Crystal Lake ...	Snowsheds and signals in snowsheds
195.70	West of Shed 47.....	Tunnel No. 12.....Side and overhead
195.20	West of Shed 47.....	Tunnel No. 11.....Side and overhead
195.10	West of Shed 47.....	Tunnel No. 10.....Side and overhead
194.90	West of Shed 47.....	Tunnel No. 9.....Side and overhead
194.30	West of Shed 47.....	Tunnel No. 8.....Side and overhead
194.25	West of Shed 47.....	Stone Wall.....Side
194.10	West of Shed 47.....	Tunnel No. 7.....Side and overhead
193.70	West of Shed 47.....	Tunnel No. 6.....Side and overhead
191.75	West of Norden.....	Signal Bridge.....Overhead
189.88	West of Norden.....	Signal Bridge No. 1901.....Overhead
184.40	West of Troy.....	Signal Bridge No. 1841.....Overhead
182.38	West of Troy.....	Signal Bridge No. 1823.....Overhead
181.00	West of Troy.....	Tunnel No. 4.....Side
180.70	West of Troy.....	Tunnel No. 3.....Side and overhead
180.38	Cisco.....	Signal Bridge No. 1803.....Overhead
164.34	West of Blue Canon.....	Tunnel No. 1.....Side and overhead
132.90 to 122.00	West of New England Mills to West of Auburn.....	Rock Cuts.....Side
127.86	Bowman.....	Highway Bridge.....Overhead
120.50	Newcastle.....	Tunnel No. 18.....Side and overhead
111.21	East of Rocklin.....	Under Structure.....Side and overhead

8. SPEED RESTRICTIONS FOR OTHER THAN MAIN TRACKS	With Caution Not Exceeding MPH
Through sidings, yard and other tracks, wyees, balloon tracks, crossovers and turnouts, except:.....	15
Through slip switches.....	10
Through turnouts on other than sidings.....	10
On branches.....	10
On branches not otherwise specified.....	10
On "R" St. Sacramento, between Front St. and Brighton.....	10
On Mather Field spur.....	10
On back tracks or engine leads to turntable, Sacramento.....	10
On tracks serving McClellan Field (Planehaven) ...	10
Through siding and turnout at Polk.....	20
Westward through crossover Norden, from No. 2 to No. 1 Track.....	25
Through siding Norden (and turnouts).....	20

**SPECIAL INSTRUCTIONS – ROSEVILLE SUBDIVISION**

**SPEED RESTRICTIONS FOR TRAINS:** Maximum speed of trains in territory shown below is subject to further restrictions applicable to engines in the train as shown in **SPEED RESTRICTIONS FOR ENGINES** appearing on page 14, and **MAXIMUM SPEED PERMITTED WITH CERTAIN EQUIPMENT** and **OTHER MAXIMUM SPEEDS** appearing on Page 15 of Special Instructions for All Subdivisions. Speed must be further reduced as prescribed by speed signs, except as specifically authorized by Special Instructions herein, or by timetable bulletin.

All trains must run carefully during and after heavy storms, particularly when the track is apt to be affected. When fog, storms or other conditions obscure track or signals, speed of trains must be so reduced as to permit strict observance of signals and **INSURE SAFETY, REGARDLESS OF TIME.**

TERRITORY			PASSENGER TRAINS	FREIGHT	TERRITORY			PASSENGER TRAINS	FREIGHT
MP	MP	Column:	1	2	MP	MP	Column:	1	2
<b>EASTWARD, SACRAMENTO TO SPARKS:</b> 88.54 to 89.20..... 10 10 89.20 to 90.00..... 25 25 90.00 to 91.61..... 35 35 91.61 to 92.56 (interlocking and bridge)..... 25 25 92.56 to 93.00..... 50 50 93.00 to 102.50..... 70 55 102.50 to 103.15..... 35 35 103.15 to 106.08..... 45 45 106.08 to 106.74..... 15 15 106.74 to 108.12..... 35 35 108.12 to 113.00..... 70 55 113.00 to 141.95..... 50 50 141.95 to 193.00..... 30 30 193.00 to 208.00..... 30 25 208.00 to 224.00..... 40 40 224.00 to 242.20..... 45 45 242.20 to 244.16 (Reno)..... 20 20 244.16 to 246.20..... 30 30					<b>WESTWARD, SPARKS TO SACRAMENTO:</b> 246.20 to 244.16..... 30 30 244.16 to 242.20 (Reno)..... 20 20 242.20 to 224.00..... 45 45 224.00 to 208.00..... 40 40 208.00 to 194.00..... 30 30 194.00 to 115.13..... 30 25 115.13 to 108.12..... 40 40 108.12 to 106.74..... 35 30 106.74 to 106.08..... 15 15 106.08 to 102.50..... 45 45 102.50 to 93.00..... 70 55 93.00 to 92.56..... 50 50 92.56 to 91.61 (bridge and interlocking)..... 25 25 91.61 to 90.00..... 35 35 90.00 to 89.15..... 25 25 89.15 to 88.54..... 10 10				
<b>EASTWARD, POLK TO ELVAS:</b> 132.00 to 133.17..... 70 55 133.17 to 134.10..... 45 45 134.10 to 136.00..... 40 40 136.00 to 136.38 (wy to Roseville)..... 25 25 136.00 to 136.36 (wy to Sacramento) ... 20 20					<b>WESTWARD, ELVAS TO POLK:</b> 136.38 to 135.99 (wy from Roseville) ... 25 25 136.36 to 135.99 (wy from Sacramento) 20 20 135.99 to 134.10..... 40 40 134.10 to 132.00..... 70 55				
<b>EASTWARD, BRIGHTON TO PLACERVILLE:</b> 94.67 to 94.74..... ... 15 94.74 to 111.05..... ... 25 111.05 to 111.34..... ... 15 111.34 to 122.20..... ... 20 122.20 to 139.00..... ... 20 139.00 to 139.30..... ... 15 139.30 to 149.07..... ... 20 149.07 to 150.01..... ... 10					<b>WESTWARD, PLACERVILLE TO BRIGHTON:</b> 150.01 to 149.07..... ... 10 149.07 to 139.30..... ... 20 139.30 to 139.00..... ... 15 139.00 to 111.34..... ... 20 111.34 to 111.05..... ... 15 111.05 to 94.74..... ... 25 94.74 to 94.67..... ... 15				
<b>EASTWARD, CITRUS TO FAIR OAKS</b> ... 20					<b>WESTWARD, FAIROAKS TO CITRUS</b> ... 20				
<b>EASTWARD, SACRAMENTO TO ISLETON:</b> 89.59 to 122.09..... ... 20					<b>WESTWARD, ISLETON TO SACRAMENTO:</b> 122.09 to 89.59..... ... 20				

Speed restrictions for other than main track – see Item 8, Page 33.

At Reno, when engine passes last crossing within limits of restriction in direction of movement, speed may be resumed to that shown on next speed sign.

Freight trains must not exceed 20 MPH (westward) from MP 192.10 (Norden) to MP 113.26 (Loomis) and (eastward) from MP 192.00 (Norden) to MP 209.10 (Truckee) when retaining valves required in accordance with Air Brake Rule 17.

Engines with flanger may operate at speeds shown in Column 1 not exceeding 40 MPH and between Colfax and Truckee may operate at 35 MPH.

Freight trains, light engines and caboose hops may operate at Column 1 speeds not exceeding 65 MPH when authorized by train order, provided train has no restricted cars and does not exceed 80 tons per operative brake and 120 cars.

Eastward trains between Norden and Truckee and westward trains between Norden and Loomis may operate at Column 1 speeds provided train has no restricted cars and does not exceed 80 tons per operative brake and 120 cars or on trains exceeding 120 cars does not exceed the tons per operative brake for number of cars in train as designated by chart on Page 16, Item 15, All Subdivisions.

**RULE 4-B.** WPRR timetable bulletins will be posted at Carlin, Wendel and Sparks.

**RULES 7-A, 10-G and 10-H:** Yellow flags, unattended red flags, red lights and green flags will be placed to the left of track between 246.2 and MP 249.39.

**RULE 10-J.** Speed signs to right of track with one track intervening:

Westward	Reading
MP 343.80	70-55
MP 417.46	70-55

Speed signs to left of track with one track intervening:

Westward	Reading
MP 245.20	20

Speed signs located to left of track in direction of movement:

Westward	Reading	Eastward	Reading
MP 249.14	30	MP 244.16	30
MP 249.36	70-55	MP 247.14	70-55
MP 266.81	60-55	MP 248.61	60-55
MP 276.12	55	MP 252.70	60-55

**RULE 14. Tule:** WPRR westward trains must sound whistle signal o - -, when passing sign reading "WP whistle" located at MP 425.10.

**RULE 20.** Sections of WPRR schedules required to display signals will display green flags in addition to green lights.

**RULE 82-A.** Extra trains originating at Hazen and operating between Hazen and Fallon will display engine number of the lead unit leaving Hazen and are authorized to operate as extra trains between Hazen and Fallon without obtaining a clearance at Hazen or Fallon.

**RULE 83.** Extra trains originating at Hazen enroute Fallon, in addition to information required by train register, must register destination of trip (turning point) and date of departure in the column captioned "Signals." When trip has been completed, date of arrival at Hazen must also be entered in column captioned "Signals."

An extra train enroute Fallon from Hazen must not leave Hazen until it has been ascertained from the train register that all preceding extra trains via the route to be used have completed their trip and registered time and date of arrival at Hazen accordingly.

**RULE 83-A.** At the following stations, only the trains indicated will register.  
Hazen—trains via Fallon branch.

**RULE 83-B.** At open train-order offices, trains may register by ticket as follows:

Carlin.....Westward WPRR trains.  
Train Nos. 5 and 6 will register by ticket at Carlin. Train orders and clearances will be delivered by messenger to Train No. 6.

**RULE 93.** Yard limits within which the provisions of Rule 93 will apply are established at the following points:

West MP		East MP
237.49	Sparks	249.48
	Hazen (Mina Branch)	289.47
	Hazen (Fallon Branch)	289.23
356.00	Wendel	360.08
415.36	Mina	418.00
533.40	Carlin	536.46

**Carlin:** Eastward trains via Southern Pacific portion of paired track must not pass stop sign located at Mile Post 533.75 unless orally authorized or proceed signal received.

**Sparks:** When trains are to be crossed over westward main track, switchman must not give proceed signal to engineer until trains moving on westward main track have stopped or crossover switches are lined for movement.

Movement from engine leads must not foul eastward main track except on proceed signal or oral authorization from switchman or on proceed signal from trainman of the same crew.

Switchman at Sparks must use green flag by day and green light by night in giving proceed signals to trains for movement on yard tracks and when making moves of any kind with road engines unless movements are being made by oral authorization.

**RULE D-97** will apply:

Between Sparks and beginning of CTC Vista.  
From Carlin to Weso and between Rose Creek and beginning CTC Perth.

**RULE 99.** Will not apply on Fallon branch.

**RULE 99-C.** Will apply on Mina Branch.

**RULE 103-A.** Automatic crossing gates:

At the following stations there are crossings protected by gates which are not actuated when trains are stopping at station to receive or discharge traffic until train starts to move toward crossing, and speed of 10 MPH must not be exceeded until gates are down:

Station	Location	Direction	MP
Reno.....	Sierra St. ....	Westward	242.80
Reno.....	Virginia St.....	Westward	243.00
Reno.....	Center St.....	Westward	243.10

Locations at which train must stop to avoid unnecessary operation of crossing gates while receiving or discharging traffic:

Station	Location	Direction
Reno.....	60 ft. east of Center St.....	Westward
Reno.....	230 ft. east of Virginia St. ....	Westward
Reno.....	60 ft. east of Virginia St. ....	Westward
Winnemucca.....	200 ft. west of Bridge St. ....	Eastward

**Winnemucca:** Crossing gate key control installed on Crossing Case 4175, Bridge Street. Eastward trains making stop west of Bridge Street on siding on house track must actuate key start before entering crossing.

Westward freight trains stopping to perform switching must leave train east of Bridge St. crossing or in siding, so as not to block crossing while engine is being attached or detached.

Eastward trains stopping on main track or siding at Winnemucca must stop 200 feet west of Bridge St. markers on south side of tracks.

**Battle Mountain:** Freight trains stopping to perform switching must leave train east of main road crossing to avoid blocking crossing when engine is coupled to train.

**RULE 104.** The normal position of rigid switches at end of double track and junctions is as follows:

Hazen (Mina Branch).....For controlled siding.  
Hazen (Fallon Branch).....For Mina Branch.

**RULE 107.** Station train indicator provided in approach to following station:

Westward  
Reno (On signal bridge with Signal 2437)

When illuminated this indicator will convey the following information:

TRAIN—Train at platform on opposite track.  
CLEAR—Indicator in service.

When neither TRAIN nor CLEAR is illuminated, indicator is out of service and prompt report must be made to Chief Train Dispatcher.

**RULE 204.** WPRR train orders and clearances will be issued at SP train order office Wendel, and will apply to those who are to execute them on WPRR tracks between Flanigan and Carlin.

WPRR train orders and clearances for eastward SP trains will be issued at SP train order office, Sparks, and will apply to those who are to execute them on WPRR tracks between Weso and Carlin.

**SPECIAL INSTRUCTIONS — SPARKS SUBDIVISION**

**RULE 221.** Lights will not be displayed in train order signals on the Mina Branch.

**RULE D-251** will apply as follows:

On both tracks between Sparks and beginning of CTC Vista.  
On both tracks from end of CTC Perth to Rose Creek.  
On both main tracks between MP 336.50, Flanigan and interlocking limits, MP 337.70.

**RULE 292. Carlin:** Eastward SP trains or engines moving from west detour to Carlin Yard must not pass light unit mounted on mast at MP 534.10 on west detour unless flashing white light is displayed or proceed signal is received from switchman or orally authorized to proceed.

When flashing white light is displayed, trains and engines may proceed at restricted speed on route lined without stopping.

**RULE 306.** The following block signals equipped with triangular plate bearing the letter "P" have included in their control limits some special protective device. Absolute signals are listed as "P-A" or "P-SA"; interlocking signals are listed as "I" or "P-SA."

Eastward Signal	Protection	Westward Signal
P-2508		P-A
P-A	Rock slide fence, MP 252.47 .....	P-A
		P-A
P-A	Rock slide fence, MP 254.52 .....	P-2553
P-A		
P-2554		P-A
P-A	Rock slide fence, MP 256.59 .....	P-A
		P-A
P-A	Collision detector, roadway underpass, MP 275.36	P-A
		P-A
P-A	Spring switch west end siding, Winnemucca .....	
	Spring switch east end siding, Winnemucca .....	P-A
	Rock slide fence, MP 517.50-MP 518.10 .....	P-5181
	Rock slide fence, MP 524.38 .....	P-5255
	Rock slide fence, MP 527.00-MP 527.57 .....	P-5277
	Rock slide fence, MP 530.54-MP 530.57 .....	P-5315
	Rock slide fence, MP 530.65-MP 530.73 .....	P-5315

**AUTOMATIC BLOCK SIGNAL SYSTEM**

**RULE 505. Sparks:** Eastward freight trains, except OAOGM, OAOGH, RVNPNY, RVRGY, RVOGY and RVOGP, must stop before passing Signal 2452 unless proceed signal received from switchman or orally authorized. If proceed signal received from switchman or orally authorized and signal displays stop indication, movement may be made as prescribed by Rule 507.

Signal 2468 governs movement of eastward trains from yard tracks. This signal is normally dark until switches are lined for crossover movement. If proceed signal received from switchman or orally authorized and signal displays stop indication, train may proceed in accordance with Rule 513.

Westward freight trains, except UPOAM, UPSFF, UPMIA, UPWSA, RGMIA, RGSFF and OGOAY, must stop before passing Signal 2467 unless proceed signal received from switchman or orally authorized. If proceed signal received from switchman or orally authorized and signal displays stop indication, movement may be made as prescribed by Rule 507.

**Carlin:** Signal 5345 governs movement of westward trains from yard tracks and is normally dark until switches are lined for crossover movement. If proceed signal received from switchman or orally authorized, and signal displays stop indication, train may proceed in accordance with Rule 513.

**Flanigan:** Automatic block signals on both main tracks between MP 336.50 and interlocking limits MP 337.80 govern movements and designated current of traffic only.

Westward interlocking signal west end double track MP 336.50 governs movements via WPRR Main Track.

**RULE 538. SPRING SWITCHES**

Spring switches equipped with facing point locks are located as follows:

Location	Normal Position
Winnemucca.....East end siding .....	Main track
Winnemucca.....West end siding .....	Main track
Weso.....West switch, west crossover between SP and WPRR main tracks.....	WPRR main track
Weso.....East switch, east crossover between WPRR and SP main tracks.....	WPRR main track
* Lovelock.....West end westward siding.....	Westward track
* Lovelock.....East end eastward siding.....	Eastward track
* Rye Patch.....East end middle siding.....	Eastward track
* Mote.....West end siding.....	Main track (Push buttons in box on relay case north of signal)
* Mosel.....West end siding.....	Main track (Push buttons in box on relay case south of signal)

\* Equipped with switch point indicator.

**Sparks:** Spring switches equipped with switch point indicators are located as follows:

- East end of Tracks 21 and 22.
- West end of Tracks 21 and 23.

**RULE 605. INTERLOCKING**

**Wendel-Flanigan:** Limits extend between westward signal west end double track MP 337.7, Flanigan and eastward signal MP 356.6, Wendel, and is under control of operator, Wendel.

Train using switches at Herlong must occupy main track continuously or leave main track switch open while work is being performed. Tracks at Herlong must not be used for meeting or passing of trains.

**Flanigan:** Beginning of WPRR TCS, MP 336.33.

**WESO:** Limits extend between eastward signal on SP track, MP 420.75, and eastward signal on WPRR track, MP 535.80, to westward signals on SP track, MP 421.00, and westward signal on WPRR track, MP 536.00, and is under the control of WPRR train dispatcher at Sacramento.

East switch of west crossover and west switch of east crossover are dual control switches. When necessary to hand throw these switches permission must be obtained from WPRR train dispatcher, except when movement is made under the provisions of Rule 633(c), and be governed by Rules 771 and 772. Telephones located at interlocking signals.

West switch of west crossover equipped with an electric switch lock. Permission must be obtained from WPRR train dispatcher before movement is made through crossovers from WPRR main track to SP main track and be governed by Rule 663(b).

Letter "A" on westward home signal at Weso applies for movements to WPRR and for movements to SP track from beginning of CTC, MP 420.75, to westward absolute signal, east end Winnemucca siding at MP 417.55. If westward signal displays stop indication and cannot be cleared by WPRR dispatcher movement must not be made to SP track without SP dispatcher's permission under Rule 776. In addition, pertinent Rule 663(b) or 663(c) will govern through Interlocking, MP 421.00 to MP 420.75.

When interlocking signals display stop indication and cannot be cleared by WPRR train dispatcher, movement, except westward movement to WPRR track, may be made under the provisions of Rule 663(b), except if unable to contact WPRR train dispatcher and it can be seen there is no train closely approaching the route to be used, movement may be made as prescribed by Rule 663(c). When movement is made under the provisions of Rule 663(c), a member of crew must examine switches to see that points are in proper position for movement, and on dual control switches that selector level is placed in "hand" position until movement over switch has been completed. After movement has been completed dual control switches must be restored to "motor" position and locked.

When interlocking signals display stop indication, westward movement to WPRR track may only be made as prescribed by WPRR Rule 509(a).

Westward inferior WPRR trains must arrive Weso sufficiently in advance of superior WPRR trains to avoid delaying them between Weso and Winnemucca.

**RULE 705. LETTER TYPE INDICATORS**

Indicators located as follows:

Illum. Letter	On Signal	Approaching	Authorizes and requires movement as follows
S	P-A	Winnemucca eastward	Enter siding.
S	P-A	Winnemucca westward	Enter siding.

**RULE 705. HOT BOX DETECTORS**

Illum. Letter	On Signal	Approaching	Location of Readout
H	2683	Thisbe	Westward Absolute Signal W. E. Thisbe
W	2684	Fernley	
W	2713	Thisbe	
H	2742	Fernley	Eastward Absolute Signal E. E. Fernley
H	3223	Ocala	Westward Absolute Signal W. E. Ocala
W	3224	Toy	
W	3255	Ocala	
H	3256	Toy	Eastward Absolute Signal E. E. Toy
W	3460	Colado	
H	3478	Colado	MP 350.7 Colado
H	3541	Colado	MP 350.7 Colado
W	3559	Colado	
W	3784	Imlay	
H	3824	Imlay	MP 384.2 Imlay
H	3855	Imlay	MP 383.1 Imlay
W	3881	Imlay	

Illum. Letter	On Signal	Approaching	Location of Readout
H	4103	Rose Creek	MP 407.8 Rose Creek
W	4104	Winnemucca	
W	4127	Rose Creek	
H	4150	Winnemucca	MP 417.4 Winnemucca
H	4243	Tule	MP 422.8 Tule
W	4293	Tule	
H	4631	Valmy	MP 460.5 Valmy
W	4653	Mote	
H	4893	Argenta	MP 487.4 Argenta
W	4917	Argenta	
H	5091	Beowawe	MP 507.7 Beowawe
W	5133	Beowawe	

**SCANNER SITE**

MP	Type	Direction	Location
251.6	D	West	Hafed
270.5	A	East and West	Thisbe-Fernley
297.0	C	East and West	Massie-Upsal
323.7	A	East and West	Ocala-Toy
346.2	A	East	Lovelock-Colado
355.8	A	West	Colado-Woolsey
380.2	A	East	Humboldt-Imlay
387.2	A	West	Imlay-Mill City
412.0	A	East and West	Rose Creek-Winnemucca
427.3	A	West	Tule-Golconda
465.0	A	West	Valmy-Mote
491.0	A	West	Argenta-Mosel
512.5	A	West	Beowawe-Harney
639.1(WPRR)	D	East	Carlin

Refer to Rule 705 All Subdivisions.

**RULE 760. CENTRALIZED TRAFFIC CONTROL**

Limits extend from MP 249.27 Vista to MP 340.26 Perth.

Limits extend from MP 406.50, Rose Creek, to MP 420.75, Weso. Trains required to enter Winnemucca siding must not pass absolute signal in advance of spring switch until switch has been lined for siding.

Westward absolute signal located at crossover west end of Winnemucca stock track applies for movements to main line over crossover only and does not restrict movements on house track.

**GENERAL REGULATIONS**

**RULE 812.** Be governed by current timetables, bulletins and rules of WPRR, on WPRR track between Carlin and Flanigan.

**SPECIAL INSTRUCTIONS — SPARKS SUBDIVISION**

**RULE 825.** Not less than five hand brakes must be set on east end of freight trains or cars in Sparks yard. Hand brakes will not be set if outgoing crew takes charge of train on arrival and if inbound crew is advised by yardmaster that engine is not to be detached.

**RULE 827.** Dragging equipment detectors located at:

MP	Location
479.65.....	East of Battle Mountain
498.60.....	East of Mosel
512.90.....	East of Beowawe

Refer to Rule 827, All Subdivisions.

**RULE 872.** Enginemen taking charge of road engines at Sparks and Carlin will consider engines as having been amply supplied with fuel, water, sand, and other supplies.

**AIR BRAKE RULES**

**FREIGHT TRAINS**

**RULE 17.** Retaining valves must be used on descending grades as follows:

**Reservation to Schurz:**

**WITHOUT DYNAMIC BRAKE IN OPERATION:** One retaining valve for each 80 tons in train. If gross tonnage exceeds 80 tons per operative brake, retaining valves must be used on all cars and speed must not exceed 15 MPH.

**WITH DYNAMIC BRAKE IN OPERATION:**

Permissible Tons Per Unit Without Retaining Valves*	Basic-Dynamic Brake		Extended Range Dynamic Brake		
	4 Axle	6 Axle	4 Axle	6 Axle	8 Axle
	650	950	800	1200	1600
1600	2400	2000	3000	4000	

With dynamic brake in operation but WITHOUT pressure maintaining system of braking:  
 With dynamic brake in operation and WITH pressure maintaining system of braking:

If permissible tonnage is exceeded, one retaining valve must be used for each 150 tons in excess thereof.  
 Locomotive classes EF 425, EF 623, EF 625, EF 630, EF 636, GF 425 (except units 6700-6727), GF 628, GF 630, GF 633, EF 850B and GF 850 are equipped with extended range dynamic brake.

\*If any unit having basic dynamic brake is operated with units having extended range dynamic brake, all units in consist must use tonnage authorized for units having basic dynamic brake.

**RULE 24-B. Sparks:** Incoming engineer, after completing stop, must make a full service brake application leaving brakes applied. When outgoing crew takes charge of train on arrival or otherwise is assured, upon request, that continuity of brake pipe has not been disturbed, engineer will release brake and proceed.

**RULE 25.** Will apply to eastward trains at Reservation when retaining valves are being used.

**RULE 33. Reservation to Schurz**

Maximum tonnage per operative brake—80 tons, except with dynamic brake and pressure maintaining system of braking in operation with not more than 20 cars for each six axles of dynamic brake; with speed not exceeding 25 MPH, and with all retaining valves on loaded cars in high pressure position—100 tons.

Should dynamic brake failure occur while handling in excess of 80 tons per operative brake, train may proceed at speed not exceed-

ing 15 MPH if in judgment of conductor and engineer it is safe to do so, and provided retaining valves are used as prescribed by **Air Brake Rule 17.**

Restrictive grades are as follows:

MINA BRANCH			
Eastward	MP to MP		Speed MPH
	337.5	340.0	25
	347.5	351.5	25
	394.2	396.6	25
Westward	394.2	393.0	25

**MISCELLANEOUS**

Engines listed must not operate on tracks shown below:

Class of Engine	Restricted Tracks
All engines.....	East Colado—Beyond curved portion of track at either end of Nevada Barth track. Carlin—Vogler spur over track scale.
All except AS407, 409, 410, ES 406, 408, 409, BS 412, GS 404, 407 class.....	Reno—All industry tracks north of eastward main track between Park St. and WPRR interchange.

Load limit (car and contents):

*Sparks-Carlin.....	315,000 pounds
*Hazen-Fallon.....	263,000 pounds
Hazen-Wabuska.....	281,000 pounds
*Wabuska-Mina.....	263,000 pounds

\*Refer to All Subdivisions, Page 15, Miscellaneous, Item No. 11  
 #Speed of trains handling cars with gross weight in excess of 199,000 pounds must not exceed 20 MPH.

Unless authorized by Superintendent, heavier loads must not be handled.  
 SP and WPRR eastward trains will use WPRR track from Weso to Carlin.  
 SP and WPRR westward trains will use SP track from Carlin to Weso being governed by SP rules, timetable-special instructions and timetable bulletins.

Current of traffic on SP track from Carlin to Weso is westward and trains will operate under SP rules applicable to double track. Movements against the current of traffic on SP track must not be made except under flag protection or as authorized by train order.

**LOCATION OF OVERHEAD AND SIDE STRUCTURES NOT STANDARD CLEARANCE ON MAIN TRACK AND SIDINGS**

MP	Location	Description
249.84	Vista.....	Truckee River bridge No. 5.....Overhead & side
250.99	Vista.....	Truckee River bridge No. 6.....Overhead & side
258.07	Patrick.....	Truckee River bridge No. 7.....Overhead & side
299.87	Wadsworth.....	Truckee River bridge No. 1.....Side
295.05	.....	Government canal bridge.....Side
302.08	Fallon.....	Carson River bridge.....Side
302.50	Fallon.....	Government canal bridge.....Side
518.91	Barth.....	Humboldt River bridge No. 6.....Side
519.68	Barth.....	Humboldt River bridge No. 8.....Overhead & side
523.25	.....	WPRR crossing.....Overhead
523.34	.....	Humboldt River bridge No. 14.....Overhead & side
525.15	Palisade.....	Humboldt River bridge No. 15.....Side
525.20	Palisade.....	Tunnel No. 1.....Overhead & side
525.42	Palisade.....	Humboldt River bridge No. 16.....Side

# SPECIAL INSTRUCTIONS — SPARKS SUBDIVISION

**SPEED RESTRICTIONS FOR TRAINS:** Maximum speed of trains in territory shown below is subject to further restrictions applicable to engines in the train as shown in **SPEED RESTRICTIONS FOR ENGINES** appearing on page 14, and **MAXIMUM SPEED PERMITTED WITH CERTAIN EQUIPMENT** and **OTHER MAXIMUM SPEEDS** appearing on page 15 of Special Instructions for All Subdivisions. Speed must be further reduced as prescribed by speed signs, except as specifically authorized by Special Instructions herein, or by timetable bulletin.

All trains must run carefully during and after heavy storms, particularly when the track is apt to be affected. When fog, storms or other conditions obscure track or signals, speed of trains must be so reduced as to permit strict observance of signals and **INSURE SAFETY, REGARDLESS OF TIME.**

TERRITORY			PASSENGER TRAINS	FREIGHT	TERRITORY			PASSENGER TRAINS	FREIGHT
MP	MP	Column:	1	2	MP	MP	Column:	1	2
<b>EASTWARD, SPARKS TO WESO:</b>					<b>WESTWARD, CARLIN TO SPARKS:</b>				
246.20 to 247.14			30	30	534.80 to 533.90			25	25
247.14 to 249.36			70	55	533.90 to 528.00			60	55
249.36 to 249.40			60	55	528.00 to 525.86			45	45
249.40 to 252.06			70	55	525.86 to 517.90			55	50
252.06 to 252.70			40	40	517.90 to 500.91			70	55
252.70 to 253.80			60	55	500.91 to 500.31			65	55
253.80 to 258.06			70	55	500.31 to 476.00			70	55
258.06 to 258.08			50	50	476.00 to 475.30			45	45
258.08 to 262.34			70	55	475.30 to 442.60 (428.62)			70	55
262.34 to 264.81			60	55	428.62 to 424.74			60	55
264.81 to 270.85			70	55	424.74 to 417.46			70	55
270.85 to 273.76			60	55	417.46 to 417.44 (Winnemucca)			45	45
273.76 to 274.12			55	55	417.44 to 406.54			70	55
274.12 to 340.16			70	55	406.54 to 406.50 (through turnout)			60	55
340.16 to 340.23 (through turnout)			60	55	406.50 to 344.80			70	55
340.23 to 343.80			70	55	344.80 to 343.80			40	40
343.80 to 344.80			40	40	343.80 to 340.23			70	55
344.80 to 406.50			70	55	340.23 to 340.16 (through turnout)			60	55
406.50 to 406.54 (through turnout)			60	55	340.16 to 274.12			70	55
406.54 to 417.44			70	55	274.12 to 273.76			55	55
417.44 to 417.46 (Winnemucca)			45	45	273.76 to 270.85			60	55
417.46 to 420.87			70	55	270.85 to 264.81			70	55
420.87 to WP 535.97 (through crossover to WPRR)			25	25	264.81 to 262.34			60	55
					262.34 to 258.08			70	55
					258.08 to 258.06			50	50
					258.06 to 253.80			70	55
					253.80 to 252.70			60	55
					252.70 to 252.06			40	40
					252.06 to 249.40			70	55
					249.40 to 249.36			60	55
					249.36 to 247.14			70	55
					247.14 to 246.20			30	30

**SPEED RESTRICTIONS FOR OTHER THAN MAIN TRACKS**

With Caution  
Not Exceeding  
MPH

Through yard and other tracks, crossovers and turnouts, except:	15
Through turnouts on other than sidings	10
On any wye	10
Barth: Over Nevada Barth Co. track scales	3

**SPEED RESTRICTIONS ON SIDINGS (AND TURNOUTS) AND CROSSOVERS**

Location	With Caution Not Exceeding MPH	Location	With Caution Not Exceeding MPH
Hafed	20	Lovelock-North	15
Patrick	20	Lovelock-South	15
Clark	20	Rye Patch	10
Thisbe	25	Imlay	15
Fernley	20	Cosgrave	10
Darwin	25	Winnemucca	25
Hazen	20	Preble (Crossover)	20
Massie	20	Iron Point	20
Upsal	25	Mote	20
Parran	25	Battle Mountain	20
Ocala	25	Mosel	20
Toy	25	Beowawe	20
Granite Point	25		

Freight trains, light engines and caboose hops may operate at Column 1 speeds not exceeding 65 MPH when authorized by train order, provided train has no restricted cars and does not exceed 80 tons per operative brake and 120 cars.

At Battle Mountain, when engine passes last crossing within limits of restriction in direction of movement, speed may be resumed to that shown on next speed sign.

Western Pacific Train WMX with no restricted cars, not more than 70 tons per operative brake or 70 cars, is permitted to operate at Column 1 speeds not exceeding 70 miles per hour on the Southern Pacific's portion of the paired track between Alazon and Weso.

Western Pacific freight trains may operate at Column 1 speeds not exceeding 65 MPH provided train has no restricted cars and does not exceed 80 tons per operative brake and 120 cars except trains required to operate at column 2 speeds on WPRR will not exceed column 2 speeds on Southern Pacific Track.

**SPECIAL INSTRUCTIONS — SPARKS SUBDIVISION**

**SPEED RESTRICTIONS FOR TRAINS:** Maximum speed of trains in territory shown below is subject to further restrictions applicable to engines in the train as shown in **SPEED RESTRICTIONS FOR ENGINES** appearing on page 14, and **MAXIMUM SPEED PERMITTED WITH CERTAIN EQUIPMENT** and **OTHER MAXIMUM SPEEDS** appearing on page 15 of Special Instructions for All Subdivisions. Speed must be further reduced as prescribed by speed signs, except as specifically authorized by Special Instructions herein, or by timetable bulletin.

All trains must run carefully during and after heavy storms, particularly when the track is apt to be affected. When fog, storms or other conditions obscure track or signals, speed of trains must be so reduced as to permit strict observance of signals and **INSURE SAFETY, REGARDLESS OF TIME.**

TERRITORY			PASSEN- GER TRAINS	FREIGHT	TERRITORY			PASSEN- GER TRAINS	FREIGHT
MP	MP	Column:	1	2	MP	MP	Column:	1	2
EASTWARD, HAZEN TO MINA:					① WESTWARD, MINA TO HAZEN:				
288.35 to 288.62.....			25	25	417.00 to 383.00.....			25	25
288.62 to 288.73.....			30	30	383.00 to 371.08.....			20	20
288.73 to 301.06.....			40	40	371.08 to 369.83.....			25	25
301.06 to 301.56.....			35	35	369.83 to 361.50.....			20	20
301.56 to 302.95.....			40	40	361.50 to 357.50.....			35	35
302.95 to 303.36.....			35	35	357.50 to 349.76.....			20	20
303.36 to 317.13.....			40	40	349.76 to 349.67.....			15	15
317.13 to 317.23.....			30	30	349.67 to 328.00.....			20	20
317.23 to 318.06.....			40	40	328.00 to 325.10.....			40	40
318.06 to 318.15.....			25	25	325.10 to 324.68.....			35	35
318.15 to 319.21.....			40	40	324.68 to 319.57.....			40	40
319.21 to 319.57.....			35	35	319.57 to 319.21.....			35	35
319.57 to 324.68.....			40	40	319.21 to 318.15.....			40	40
324.68 to 325.10.....			35	35	318.15 to 318.06.....			25	25
325.10 to 328.00.....			40	40	318.06 to 317.23.....			40	40
328.00 to 349.67.....			20	20	317.23 to 317.13.....			30	30
349.67 to 349.76.....			15	15	317.13 to 303.26.....			40	40
349.76 to 357.50.....			20	20	303.26 to 302.95.....			35	35
357.50 to 361.50.....			35	35	302.95 to 301.56.....			40	40
361.50 to 369.83.....			20	20	301.56 to 301.06.....			35	35
369.83 to 371.08.....			25	25	301.06 to 288.73.....			40	40
371.08 to 383.00.....			20	20	288.73 to 288.62.....			30	30
383.00 to 417.00.....			25	25	288.62 to 288.35.....			25	25
EASTWARD, HAZEN TO FALLON:					WESTWARD, FALLON TO HAZEN:				
288.35 to 303.90.....			25	25	303.90 to 288.35.....			25	25

① EF415A class engines must not exceed 25 MPH between Wabuska and Mina, and Hazen and Fallon.

**SPEED RESTRICTIONS  
FOR OTHER THAN MAIN TRACKS**

With Caution  
Not Exceeding  
MPH

Through sidings, yard and other tracks, wyees, cross-overs and turnouts.....	10
--	----



**RULE 10-I.** Rule 10-I may be applied Alazon to Carlin to WPRR trains without issuance of Form Y train orders.

Trains and engines operating Alazon to Carlin must proceed prepared to respect yellow "Proceed Prepared to Stop" signs and red "Conditional Stop" signs displayed in accordance with this rule, and when so displayed such trains may proceed only as prescribed by this rule.

**RULE 10-J.** Speed sign to right of track with one track intervening:

Westward	Reading	Eastward	Reading
MP 607.10	70-60	MP 606.63	40

Speed signs to left of track in direction of movement:

Westward	Reading	Eastward	Reading
MP 754.50	20 No. 2 Track	MP 616.25	50
MP 754.50	20		
MP 754.50	No. 2 Track		
	20		
MP 641.51	Thru turnout		
	70-60		

Speed signs duplicated to left of track:

Westward	Reading	Eastward	Reading
MP 754.50	60	MP 616.84	60
MP 739.70	70-60	MP 737.70	60
		MP 737.20	20

**RULE 82-A.** Eastward SP regular trains authorized on WPRR are also authorized to assume corresponding schedule or section of schedule at Alazon without obtaining SP clearance.

WPRR regular trains authorized on WPRR are also authorized to assume corresponding schedule or section of schedule at Alazon without obtaining SP clearance.

WPRR trains originating at WPRR Elko must obtain SP clearance "OK'd" by SP Chief Train Dispatcher.

**RULE 83-A.** Engineers on light engines terminating at Ogden, will register at Engine Crew Dispatcher's office instead of "YD" telegraph office.

Train register for this purpose is located in Engine Crew Dispatcher's office, Ogden.

**RULE 83-B.** Trains No. 5 and No. 6 will register by ticket at Carlin. Train orders and clearances will be delivered by messenger to Train No. 6.

**RULE 86.** Engines using main track within yard limits Elko must clear the time of first-class trains.

**RULE 93.** Yard limits within which the provisions of Rule 93 will apply, are established at the following points:

West MP	East MP
533.40 Carlin	536.46
554.02 Elko	557.92
780.21 Ogden	

**RULE D-97** applies:

Between Alazon and Moor.  
Between Valley Pass and Lucin and between Bridge and Ogden.  
Between Alazon to Carlin.

**RULE 103-A. Elko:** Trains stopping to perform switching must leave train to clear all street crossings.

**WELLS:** Trains stopping to perform switching must leave train to clear all street crossings.

**RULE 104.** Eastward trains after having been instructed to operate directly to D&RGW will enter connection through spring switch located just east of Signal P7802 and members of crew will hand throw switch and return switch to normal position after movement is completed.

**RULE 105. Montello:** No. 1 track is for use by eastward trains only and when necessary for westward trains to use No. 1 track permission must be obtained from train dispatcher.

**Little Mountain:** When necessary to use siding permission must be obtained from train dispatcher.

**RULE 204.** Westward WPRR trains of the Ogden or Sparks Subdivisions, with the same conductor and engineer operating through Carlin, may be issued train orders on one subdivision that affect their movement on the other or both subdivisions.

When train orders are issued at Carlin which affect movement of SP trains east of Alazon, train-order operator must deliver such train orders with a clearance OK'd by SP Chief Train Dispatcher.

**RULE 206.** Second paragraph will not apply to WPRR engines between Alazon and Carlin.

**RULE 221.** Elko is a train-order office only for train originating.

**RULE D-251** will apply as follows:

On both tracks between Alazon and Moor, Valley Pass and Lucin, and Bridge and Ogden.  
Between Alazon and Carlin.

**RULE 292. Carlin:** Westward freight trains or engines must not pass Signal 5359 unless flashing white light is displayed or proceed signal is received from yardman or orally authorized to proceed. Telephone located in shanty at east end of yard.

When Signal 5359 displays stop indication and flashing white light is displayed, such trains and engines may proceed without stopping on main track or diverging route at restricted speed.

**RULE 306.** The following block signals equipped with triangular plate bearing the letter "P" have included in their control limits some special protective device. Absolute signals are listed as P-A or P-SA:

Eastward Signal	Protection	Westward Signal
	Rock slide fence over east portal Tunnel 2 . . .	P-5401
	Rock slide fence MP 541.08 . . . . .	P-5427
	Rock slide fence, east portal Tunnel 3 . . . . .	P-5673
	High water detector, Culvert 589.33 . . . . .	P-5915
	High water detector, Culvert 591.15 . . . . .	P-5915
P-7802 . . .	Spring switch SP-DRGW connection . . . . .	
	Spring switch EE crossover—MP 780.15 . . . . .	P-7805
	SP-DRGW connection . . . . .	P-7803
	Spring switch EE crossover—MP 780.15 . . . . .	P-7801
	Spring switch EE crossover, Moor . . . . .	P-SA
	Spring switch EE eastward siding, Moor . . . . .	P-A

**SPECIAL INSTRUCTIONS—OGDEN SUBDIVISION**

Eastward Signal	Protection	Westward Signal
P-A	Spring switch west end westward siding, Valley Pass . . . . .	
	High water detector Culvert MP 672.14 westward track . . . . .	P-6733
	High water detector Culvert MP 677.32 westward track . . . . .	P-6775
	High water detector Culvert MP 679.33 westward track . . . . .	P-SA P-SA P-A
P-6780	High water detector Culvert MP 679.33 eastward track . . . . .	
	Spring switch east end eastward siding, Lucin . . . . .	P-A
P-A	Dragging equipment detector, Lakeside . . . . .	
P-7428	Fill slide detector (No. 1 track) MP 743.25 . . . . .	P-A P-A
**P-7476	Fill slide detector, east of Midlake, MP 747.66 . . . . .	P-7491
	***Dragging equipment detector (No. 1 track) MP 756.85 . . . . .	P-A Bridge

\*\*Limits of fill slide detector will be indicated by rotating red light when fill detector is actuated. Revolving red lights located as follows:

Eastward . . . . .	MP 747.6
Westward . . . . .	MP 748.1

\*\*\*Detector is self restoring to clear 100-L signal after inspection of train, push button on C.T.C. house south side of track.

**AUTOMATIC BLOCK SIGNAL SYSTEM**

**RULE 505.** Westward trains moving from SP-D&RGW connection to main track must stop at Signal P-7801 and member of crew must push button bearing number P-7801 located on signal case. When Signal P-7801 indicates proceed, train may proceed.

Westward trains finding Signal P-7803 in stop position after stopping, member of crew must push button bearing number P-7803 located on signal case. When Signal P-7803 indicates proceed, train may proceed.

After member of crew has actuated push button, if signal does not clear, train may then proceed only after complying with Rules 507 and 513, and in addition careful examination must be made of all facing point switches.

**East Carlin:** Detour extends from east ice house lead on SP to East Carlin on WPRR.

Eastward SP freight trains and other trains when so directed, also engines moving between WPRR and SP yards will use East Carlin and/or West Carlin detours.

**West Elko:** Detour extends from WPRR yard to West Elko on SP main track.

Junction switch is a spring switch and normal position is for SP main track.

Westward WPRR trains leaving yard via detour must enter approach circuit to indicate that such trains are ready to depart, and must not foul SP main track until letter "M" is displayed, or authority received from SP train dispatcher.

When Signal 5545 on SP main track displays stop indication, westward trains on SP main track after stopping and obtaining train dispatcher's permission may proceed under the provisions of Rule 507, provided it can be seen that there is no train or engine closely approaching west end of detour to enter SP main track.

**Elko:** East detour extends from SP siding to WPRR freight yard.

**Montello:** When Signal 6621 displays stop indication, permission must be obtained from train dispatcher before applying Rule 507.

**RULE 507. Elko:** When westward Signal 5565 displays stop indication, westward Southern Pacific freight trains must stop clear of Fourteenth Street crossing, and not proceed until signal displays proceed indication or it can be ascertained the block is not occupied by a preceding train or engine. Telephone installed in booth east of Fourteenth Street on north side of track.

**SPRING SWITCHES**

**RULE 538.** Spring switches equipped with facing point locks are located as follows:

Location	Normal Position
Moor . . . . .	East end crossover . . . . . Main track
Moor . . . . .	East end eastward siding . . . . . Main track
Valley Pass . . . . .	West end westward siding . . . . . Main track
Lucin . . . . .	East end eastward siding . . . . . Main track

Spring switches not equipped with facing point locks are located as follows:

Location	Normal Position
*West Elko . . . . .	West end WP detour . . . . . Main track
*Halleck . . . . .	West end siding . . . . . Westward track
*Alazon . . . . .	West switch of crossover between SP and WPRR main tracks . . . . . SP main track
*Wells . . . . .	East end siding . . . . . Eastward track
*Montello . . . . .	East end siding . . . . . Eastward track
*Montello . . . . .	West end siding . . . . . Westward track
Lucin . . . . .	West end westward siding . . . . . Westward track
Ogden . . . . .	Junction switch SP DRGW connection . . . . . Main track
*Ogden . . . . .	West switch crossover MP 780.15 . . . . . Main track
*Ogden . . . . .	East switch crossover MP 780.15 . . . . . Crossover

\*Equipped with switch-point indicator.

**RULE 705. LETTER TYPE INDICATORS**

Indicators located as follows:

Illum. Letter	On Signal	Approaching	Authorized and requires movement as follows:
M.....	5543	.....	WPRR connection West Elko.....Enter main track and proceed as prescribed by Rule D-251.
M.....	5565	.....	Elko.....Indicator applies to WPRR freight trains only. WPRR freight trains proceed on main track. If letter "M" is not displayed, WPRR freight trains enter SP siding and proceed through crossover to WPRR freight yard. Display of letter "M" at West Elko, does not relieve conductors or engineers of compliance with Rule 513.

# SPECIAL INSTRUCTIONS — OGDEN SUBDIVISION

## RULE 705. HOT BOX DETECTORS

Illum. Letter	On Signal	Approaching	Location of Readout
H	5787	Halleck	MP 576.4 Halleck
W	5829	Halleck	
H	5961	Deeth	Signal 5937
W	5999	Deeth	
H	6187	Moor	MP 616.2 Moor
W	6206	Holborn	
H	6224	Holborn	MP 625.4 Holborn
W	6225	Moor	
W	6626	Tecoma	
H	6658	Tecoma	MP 669.3 Tecoma
W	6758	Lucin	
H	6780	Lucin	Eastward Absolute Signal W.E. Lucin
H	Westward Absolute	Lemay	Westward "A" signal Signal W.E. Lemay
W	7044	Groome	
W	7063	Lemay	
H	7082	Groome	Eastward Absolute Signal E.E. Groome
H	Westward Absolute	Strongknob	Westward Absolute Signal W.E. Strongknob
W	7314	Lakeside	
W	7327	Strongknob	

Illum. Letter	ON Signal	Approaching	Location of Readout
H	MP 733.4	Lakeside	Eastward Absolute Signal E.E. Lakeside
H	MP 754.2	Bridge	Westward absolute Signal W.E. Bridge
W	7628	Little Mountain	MP 767.85 East End
H	7652	Little Mountain	Little Mountain

## SCANNER SITE

MP	Type	Direction	Location
547.1	D	West	Moleen
581.0	A	West	Halleck-Deeth
599.0	A	West	Deeth
620.6	A	East and West	Moor-Holborn
641.9	C	East	Valley Pass-Cobre
644.2	C	West	Cobre
664.0	A	East	Montello-Tecoma
665.8	C	West	Tecoma
676.4	A	East	Tecoma-Lucin
683.8	C	East and West	Lucin-Pigeon
706.0	A	East and West	Lemay-Groome
731.8	A	East and West	Strongknob-Lakeside
756.2	A	West	Bridge-Promontory Pt.
763.6	A	East	Promontory Pt.-Little Mnt.

Refer to Rule 705 All Subdivisions.

**SPECIAL INSTRUCTIONS — OGDEN SUBDIVISION**

**RULE 760. CENTRALIZED TRAFFIC CONTROL**

Limits extend from absolute signal MP 713.60 on WPRR main track and absolute signal MP 603.50 on SP main track and absolute signal MP 713.90 on WPRR main track and absolute signals MP 603.80 on SP eastward and westward main tracks. From end of double track at Moor to end of double track at Valley Pass and from west end eastward siding at Lucin to end of double track at Bridge.

At Alazon west switch of crossover between SP and WPRR main tracks is a spring switch and normal position is for SP main track.

When absolute signals display stop indication member of crew must contact train dispatcher for instructions. If signal can not be cleared train dispatcher may authorize member of crew to operate push buttons in box mounted on signal house north side SP track. Instructions are posted in box.

If absolute signal can not be cleared by operation of push buttons, movement may be made as prescribed by Rule 776 and in addition eastward movement to WPRR may only be made as prescribed by WPRR Rule 509(a).

Bottom unit of eastward three unit absolute signal located at end of double track Moor, MP 616.20 and bottom unit of westward three unit absolute signal located at end of double track Valley Pass, MP 641.60, govern movement on siding and will display lunar aspect only.

At Lucin trains moving against current of traffic finding absolute signal at west end westward siding displaying stop indication must obtain train dispatcher's permission to enter block and must ascertain that spring switch is properly lined.

Reverse movement after trailing through spring switch east end eastward siding Lucin must not be made until train dispatcher's permission obtained and it is known that switch points have moved to proper position.

On double track between Lakeside and Tresend, train movements may be made in either direction on either track, being governed by absolute and automatic signals.

Absolute signal located south of No. 2 Track, MP 752.4, governs eastward trains only.

Absolute signal located north of No. 2 Track (off trestle), MP 752.4, governs eastward trains on No. 2 Track only.

Two unit absolute dwarf signal installed north of No. 2 Track, MP 752.5, governs westward trains. Top unit governs movement of westward trains to fill on No. 2 Track. Bottom unit governs movement of westward trains to trestle on No. 2 Track.

Push buttons for clearing absolute signals actuated by dragging equipment detectors located on CTC house south of switch from eastward main Track to No. 2 Track at MP 752.50.

**GENERAL REGULATIONS**

**RULE 812.** Be governed by current timetable, bulletins and rules of WPRR, on WPRR track between Carlin and Alazon.

**RULE 816.** Members of crew making temporary repairs to hot bearings will be held personally responsible for control of burning waste to preclude possibility of starting fire on Salt Lake trestle.

**RULE 825.** At Ogden and Carlin when instructions require application of hand brakes on freight trains, outgoing crews must not release hand brakes until road engine is coupled.

**RULE 872.** Enginemen taking charge of engines at Ogden and Carlin will consider engines as having been amply supplied with fuel, water and sand.

**AIR BRAKE RULES**

**PASSENGER TRAINS**

**RULE 17.** Use of retaining valves is not required when dynamic brake is in operation and/or pressure maintaining system of braking is being used on descending grades Moor to Wells and Valley Pass to Montello.

**FREIGHT TRAINS**

Retaining valves must be used on descending grades as follows:

**Moor to Wells, Valley Pass to Montello.**

**WITHOUT DYNAMIC BRAKE IN OPERATION:**

One retaining valve for each 80 tons in train. If gross tonnage exceeds 80 tons per operative brake, retaining valves must be used on all cars and speed must not exceed 15 MPH.

**WITH DYNAMIC BRAKE IN OPERATION:**

Permissible Tons Per Unit Without Retaining Valves\*

	Basic Dynamic Brake		Extended Range Dynamic Brake		
	4 Axle	6 Axle	4 Axle	6 Axle	8 Axle
With dynamic brake in operation but WITHOUT pressure maintaining system of braking	525	775	650	950	1275
With dynamic brake in operation and WITH pressure maintaining system of braking	1800	2700	2300	3500	4600

If permissible tonnage is exceeded, one retaining valve must be used for each 150 tons in excess thereof.

Locomotive classes EF 425, EF 623, EF 625, EF 630, EF 636, GF 425 (except units 6700-6727); GF 628, GF 630, GF 633, EF 580B and GF 850 are equipped with extended range dynamic brake.

\*If any unit having basic dynamic brake is operated with units having extended range dynamic brake, all units in consist must use tonnage authorized for units having basic dynamic brake.

Retaining valves may be turned up when stops are made at any of the following stations:

Westward.....Holborn or Moor  
Eastward.....Moor, Holborn, Pequop, Valley Pass, Cobre

**RULE 17-A.** When retaining valves are used Valley Pass to Montello, stop for heat radiation need not be made if there is no indication of wheels overheating and in the judgment of engineer and conductor it is safe to proceed.

**Rule 24-B. Elko:** Incoming engineer, after completing stop, must make a full service brake application leaving brakes applied. When outgoing crew takes charge of train on arrival or otherwise is assured, upon request, that continuity of brake pipe has not been disturbed, engineer will release brakes and proceed.

**RULE 25.** Will apply to eastward trains at Valley Pass and to westward trains at Moor when retaining valves are being used, except when cars are to be set out or picked up at Cobre eastward trains may pass Valley Pass without stopping for air brake test, provided test is made at Cobre.

To avoid additional stops at stations indicated above, trains may make inspection, air brake test and turn up retaining valves when stops are made at the following stations:

Westward.....Holborn or Moor  
Eastward .....Moor, Holborn, Pequop or Valley Pass.

Flashing light temperature indicators installed at Signals 6186 and 6381, between Moor and Valley Pass. When flashing on approach of train, will indicate that the temperature is below 32 degrees.

When flashing, running test will be made. Engineer will inform trainmen in caboose that running test is to be made after which trainmen will observe whether or not brakes apply on the caboose and brake pipe pressure is being properly restored and so inform engineer. If unable to obtain a proper air test while running, train must be stopped and air brake hoses on head end blown out as prescribed by Air Brake Rule 26.

**Westward Freight Trains.** Conductor must contact engineer when engine passes station one mile sign approaching Valley Pass, and comply with addition to Rule 25, under All Subdivisions.

**Eastward Freight Trains.** Conductor must contact engineer when engine passes station one mile sign approaching Moor and comply with addition to Rule 25, under All Subdivisions.

**RULE 33.** Restrictive grades are as follows:

Eastward	MP to MP	MPH	
Cobre to East of Cobre	645.4	654.0	25
Tecoma to East of Tecoma	670.0	675.0	25
<b>Westward</b>			
Moor to Wells	616.3	607.8	25

# SPECIAL INSTRUCTIONS — OGDEN SUBDIVISION

## MISCELLANEOUS

1. Engines listed must not operate on tracks shown below:

Class of Engine	Restricted Tracks
All engines.....	Lucin — Beyond engine restriction signs on South Spur.
All engines.....	Elko — Vogeler Whse. spur over track scale.
All engines.....	Carlin — Vogeler Whse. spur over track scale.
	Little Mountain — Great Salt Lake Chemical spur over track scale.

2. Load Limit (car and contents):

Carlin-Ogden.....315,000 pounds

Unless authorized by Superintendent, heavier loads must not be handled.

Refer to All Subdivisions, Page 15, Miscellaneous, Item No. 11

3. SP and WPRR eastward trains will use WPRR track from Carlin to Alazon being governed by WPRR rules, timetable, special instructions and timetable bulletins.

SP and WPRR westward trains will use SP track from Alazon to Carlin being governed by SP rules, timetable-special instructions and timetable bulletins.

Current of traffic on SP track from Alazon to Carlin is westward and trains will operate under SP rules applicable to double track. Movements against the current of traffic on SP track must not be made except under flag protection or as authorized by train order.

## 4. LOCATION OF OVERHEAD AND SIDE STRUCTURES NOT STANDARD CLEARANCE ON MAIN TRACK AND SIDINGS

MP	Location	Description
539.54	Tunnel No. 2	Overhead & side
542.45	Humboldt River bridge No. 24	Overhead & side
566.55	Ryndon Tunnel No. 3	Overhead & side
567.19	Ryndon Humboldt River bridge No. 25	Overhead & side
569.85	Ryndon Humboldt River bridge No. 27	Overhead & side
570.36	Ryndon Humboldt River bridge No. 28	Overhead & side
769.5	Little Mountain Great Salt Lake Chemical track scales	Overhead & side
778.51	Weber River bridge No. 2	Side
	Salt Lake Trestle (between Bridge and Tresend)	Side

## SPECIAL INSTRUCTIONS — OGDEN SUBDIVISION

**SPEED RESTRICTIONS FOR TRAINS:** Maximum speed of trains in territory shown below is subject to further restrictions applicable to engines in the train as shown in **SPEED RESTRICTIONS FOR ENGINES** appearing on page 14, and **MAXIMUM SPEED PERMITTED WITH CERTAIN EQUIPMENT** and **OTHER MAXIMUM SPEEDS** appearing on page 15 of Special Instructions for All Subdivisions. Speed must be further reduced as prescribed by speed signs, except as specifically authorized by Special Instructions herein, or by timetable bulletin.

All trains must run carefully during and after heavy storms, particularly when the track is apt to be affected. When fog, storms or other conditions obscure track or signals, speed of trains must be so reduced as to permit strict observance of signals and **INSURE SAFETY, REGARDLESS OF TIME.**

TERRITORY			PASSENGER TRAINS	FREIGHT	TERRITORY			PASSENGER TRAINS	FREIGHT
MP	MP	Column:	1	2	MP	MP	Column:	1	2
<b>EASTWARD, ALAZON TO OGDEN:</b>					<b>WESTWARD, OGDEN TO CARLIN:</b>				
WP 713.67 to 603.75 (through turnout).....					780.90 to 752.12.....				
603.75 to 607.10.....					752.12 to 752.05 (through turnout).....				
607.10 to 608.63.....					752.05 to 739.70.....				
608.63 to 616.23.....					739.70 to 679.56.....				
616.23 to 616.25 (through crossover).....					Tresend and Lakeside, through cross-				
616.25 to 616.84.....					overs, ends of double track.....				
616.84 to 635.77.....					679.56 to 679.51 (through turnout).....				
635.77 to 645.02.....					679.51 to 673.70.....				
645.02 to 653.04.....					673.70 to 672.12.....				
653.04 to 658.04.....					672.12 to 658.04.....				
658.04 to 660.00.....					658.04 to 655.83.....				
660.00 to 672.00.....					655.83 to 652.50.....				
672.00 to 674.00.....					652.50 to 649.67.....				
674.00 to 679.51.....					649.67 to 646.56.....				
679.51 to 679.56 (through turnout).....					646.56 to 645.02.....				
679.56 to 739.70.....					645.02 to 641.54.....				
739.70 to 752.05.....					641.54 to 641.51 (through crossover).....				
Lakeside and Tresend, through cross-					641.51 to 635.77.....				
overs, ends of double track.....					635.77 to 616.84.....				
752.05 to 752.12 (through turnout).....					616.84 to 614.90.....				
752.12 to 780.00.....					614.90 to 613.80.....				
780.00 to 780.58 (OUR&D Limits).....					613.80 to 607.10.....				
					607.10 to 603.75.....				
					603.75 to 568.69.....				
					568.69 to 567.18.....				
					567.18 to 556.60.....				
					556.60 to 555.95.....				
					555.95 to 542.47.....				
					542.47 to 541.39.....				
					541.39 to 535.95.....				
					535.95 to 534.80.....				
*Through east crossover Tresend.....					*753.67 to 753.62 (through crossover)....				
*735.30 to 739.70.....					753.62 to 752.50.....				
*739.70 to 742.28.....					*★★752.50 to 745.25.....				
*742.28 to 745.25.....					*745.25 to 742.28.....				
*745.25 to 752.49.....					*742.28 to 739.70.....				
*★★752.49 to 756.88.....					*739.70 to 735.30.....				
					*Through east crossover Tresend.....				

\*No. 2 Track (Great Salt Lake Trestle).

★★All trains must not exceed speed of 20 MPH through turnout from eastward main track at MP 752.49.

Freight trains, light engines and caboose hops may operate at Column 1 speeds not exceeding 65 MPH when authorized by train order, provided train has no restricted cars and does not exceed 80 tons per operative brake and 120 cars, except:

- A. Eastward freight trains exceeding 5500 tons must not exceed 45 MPH between MP 645.4 and MP 660.0.
- B. Eastward freight trains exceeding 7500 tons must not exceed 55 MPH between MP 672.0 and MP 674.0.

Western Pacific Train WMX with no restricted cars, not more than 70 tons per operative brake or 70 cars, is permitted to operate at Column 1 speeds not exceeding 70 miles per hour on the Southern Pacific's portion of the paired track between Alazon and Weso.

Western Pacific freight trains may operate at Column 1 speeds not exceeding 65 MPH provided train has no restricted cars and does not exceed 80 tons per operative brake and 120 cars. Except trains required to operate at column 2 speeds on WPRR will not exceed column 2 speeds on Southern Pacific Track.

# SPECIAL INSTRUCTIONS — OGDEN SUBDIVISION

## SPEED RESTRICTIONS FOR OTHER THAN MAIN TRACKS

With Caution  
Not Exceeding  
MPH

Through yard and other tracks, crossovers and turnouts, except:.....	15
Through turnouts on other than sidings .....	10
On any wye .....	10
MP 769.5 (GSL Spur) .....	25
Through crossover MP 780.15 and SP-D&RGW con- nection .....	25

## SPEED RESTRICTIONS ON SIDINGS (AND TURNOUTS) AND CROSSOVERS

Location	With Caution Not Exceeding MPH	Location	With Caution Not Exceeding MPH
Elko .....	15	Pigeon .....	25
Elburz (Crossover) .....	15	Jackson .....	25
Halleck .....	20	Lemay .....	25
Deeth .....	20	Groome .....	25
Wells .....	15	Hogup .....	25
Moor .....	25	Strongknob .....	25
Moor (Crossover) .....	25	Lakeside (Crossover) .....	35
Holborn .....	25	Tresend (East Crossover) .....	20
Pequop .....	25	Tresend (West Crossover) .....	35
Valley Pass .....	25	Midlake (Track No. 1) .....	25
Valley Pass (Crossover) .....	45	Bridge (East Crossover) .....	25
MP 649.3 (Crossover) .....	20	Bridge (West Crossover) .....	25
Lucin-North .....	25	Little Mountain .....	10
Lucin-South .....	15		

**RULE 10-1**

Oral authorization and acknowledgments between Foremen and Engineers for trains to pass "Red Conditional Stop" signs must be worded in the following forms:

"SP FOREMAN . . . . AT MP . . . . CALLING SP (Train No.) . . . ."

(After train answers giving his identification):  
(i. e.) SP Train . . . .

**Foreman's Response**

"THIS IS SP FOREMAN . . . IN CHARGE OF THE WORK BETWEEN MP . . . AND MP . . . . SP TRAIN ORDER NO. . . . WE ARE IN THE CLEAR AND YOU MAY PROCEED PAST THE RED CONDITIONAL STOP SIGN AND THROUGH THE LIMITS OF ORDER AT . . . . MPH, REPEAT . . . . MPH"\*

**Engineer's Response**

"THIS IS ENGINEER SP TRAIN . . . . I MAY PROCEED PAST THE RED CONDITIONAL STOP SIGN AND THROUGH THE LIMITS OF ORDER NO. . . . BETWEEN MP . . . AND MP . . . AT (Speed). REPEAT (Speed) MILES PER HOUR."

Foreman must acknowledge Engineer's response as follows:

"SP TRAIN ORDER NO. . . . , BETWEEN MP . . . . AND MP . . . . . MPH\* OK."

\*When no speed restriction account above Form "Y" Train Order, tell train engineer "At Maximum Authorized Speed."

Oral authorization and acknowledgments between Foremen and Engineers for trains to pass "Red Conditional Stop" signs in multiple main track territory must be worded in following forms:

**Foreman's Response**

"THIS IS SP FOREMAN . . . . IN CHARGE OF THE WORK BETWEEN MP . . . . AND MP . . . . SP TRAIN ORDER NO. . . . WE ARE IN THE CLEAR OF TRACK . . . AND YOU MAY PROCEED PAST THE RED CONDITIONAL STOP SIGN ON TRACK . . . AND THROUGH THE LIMITS OF ORDER AT . . . . MPH, REPEAT . . . . MPH."

**Engineer's Response**

"THIS IS ENGINEER SP TRAIN . . . . I MAY PROCEED PAST THE RED CONDITIONAL STOP SIGN AND THROUGH THE LIMITS OF ORDER NO. . . . ON TRACK . . . . BETWEEN MP . . . . AND MP . . . . AT (Speed). REPEAT (Speed) MILES PER HOUR."

Foreman must acknowledge Engineer's response as follows:

"SP TRAIN ORDER NO. . . . ON TRACK . . . . , BETWEEN MP . . . . AND MP . . . . . MPH OK."

**SPEED TABLE**

TIME PER MILE	MILES PER HOUR
36"	100
37"	97.3
38"	94.7
39"	92.3
40"	90
41"	87.8
42"	85.7
43"	83.7
44"	81.8
45"	80
46"	78.3
47"	76.6
48"	75
49"	73.5
50"	72
51"	70.6
52"	69.2
53"	67.9
54"	66.7
55"	65.5
56"	64.3
57"	63.2
58"	62.1
59"	61
1'00"	60
1'01"	59
1'02"	58.1
1'03"	57.1
1'04"	56.2
1'05"	55.4
1'06"	54.5
1'07"	53.7
1'08"	52.9
1'09"	52.2
1'10"	51.4
1'11"	50.7
1'12"	50
1'13"	49.3
1'14"	48.6
1'15"	48
1'16"	47.4
1'17"	46.8
1'18"	46.2
1'19"	45.6
1'20"	45
1'25"	42.4
1'30"	40
1'35"	37.9
1'40"	36
1'45"	34.3
1'50"	32.7
1'55"	31.3
2'00"	30
2'15"	26.7
2'30"	24
2'45"	21.8
3'00"	20
3'30"	17.1
4'00"	15
5'00"	12
6'00"	10
7'00"	8.6
7'30"	8
8'00"	7.5
10'00"	6