

Atlantic Coast Line Railroad Company

SUPPLEMENT TO
RULES AND REGULATIONS
FOR THE GOVERNMENT
OF THE
OPERATING DEPARTMENT

ASPECTS AND INDICATIONS
OF AUTOMATIC BLOCK AND
INTERLOCKING SIGNALS

EFFECTIVE SEPTEMBER 1, 1947

Superseding Aspects and Indications of
Automatic Block and Interlocking Signals
shown on pages 159-167, in Book of Rules
dated November 1, 1926.

L. S. JEFFORDS,
General Manager.

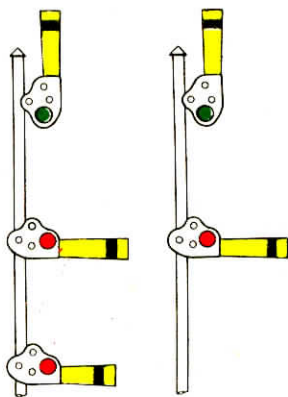

A

B

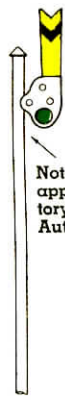

C

Note: This indication applies only in territory not equipped with Automatic Block Signals

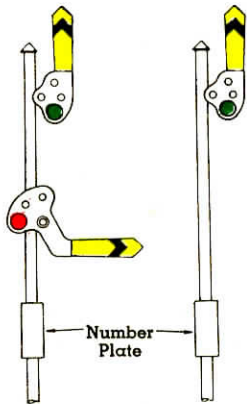

D

E

Number Plate

Indication: Proceed
Name: Clear



F



G



H

Number Plate



I



J

Flashing Green

Indication: Proceed
Name: Clear

RULE 281 B

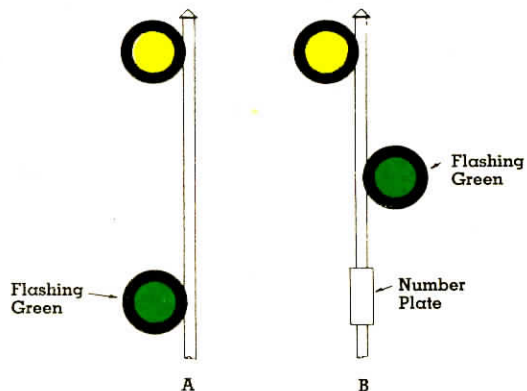

Indication: Proceed approaching next signal at limited speed.

Name: Approach Limited.

RULE 281 C

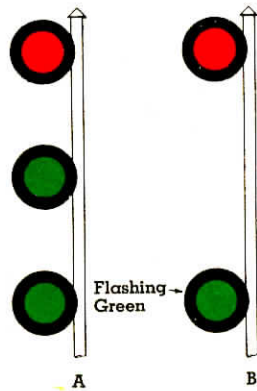

Indication: Proceed: limited speed within Interlocking Limits.

Name: Limited—Clear.

RULE 282

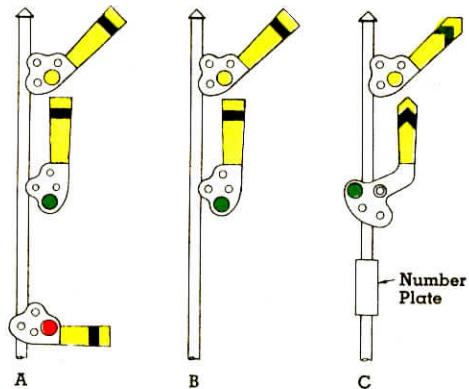

RULE 282 A

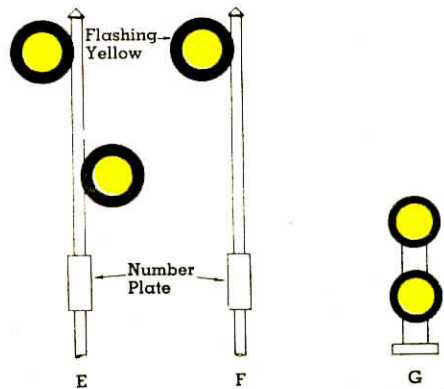
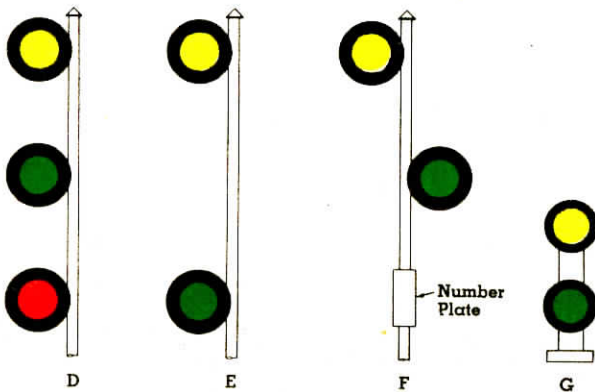
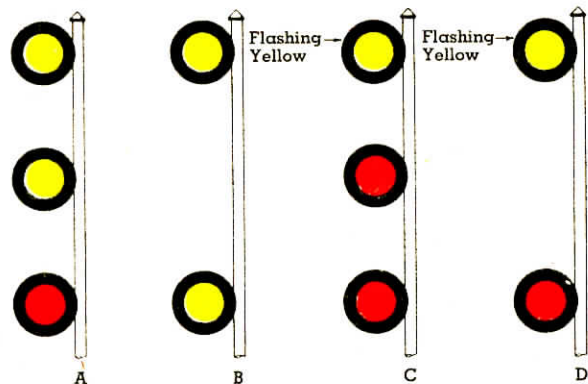

Indication: Proceed approaching next signal at medium speed.

Name: Approach Medium.

Indication: Proceed preparing to stop at second signal.

Name: Advance Approach.

RULE 283

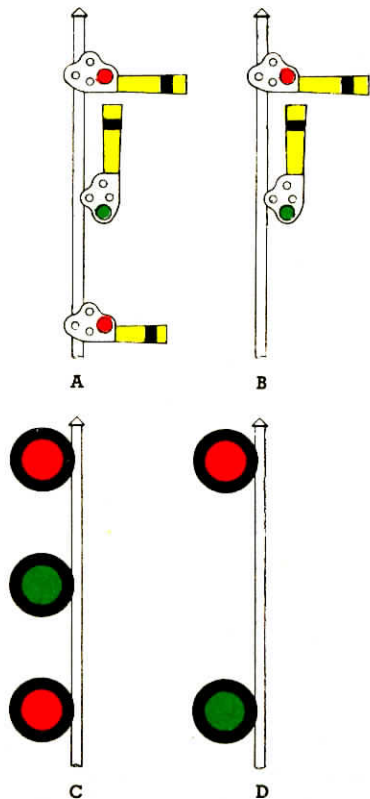

Indication: Proceed; medium speed within Interlocking Limits.

Name: Medium—Clear.

RULE 283 A



Indication: Proceed preparing to stop at second signal; medium speed within Interlocking Limits.

Name: Medium—Advance Approach.

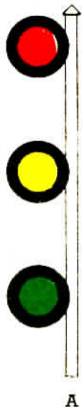

Indication: Proceed at medium speed approaching next signal at slow speed.

Name: Medium—Approach Slow.

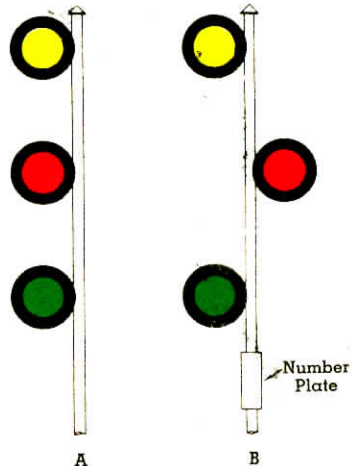

Indication: Proceed approaching next signal at slow speed. Train exceeding medium speed must at once reduce to that speed.

Name: Approach Slow.

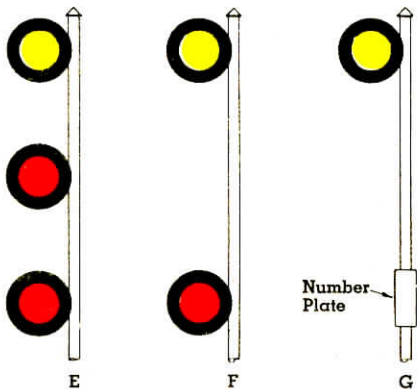
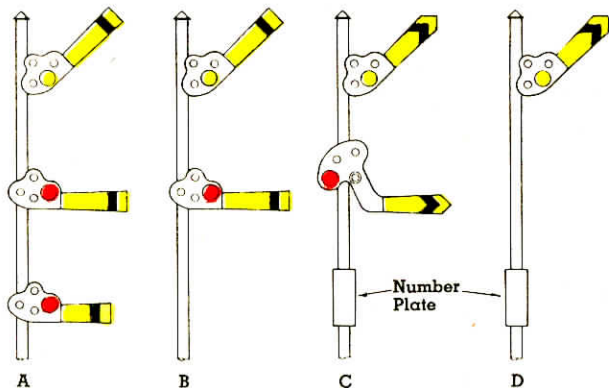

Indication: Proceed preparing to stop at next signal. Train exceeding medium speed must at once reduce to that speed.

Name: Approach

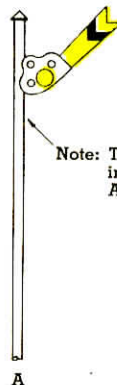

Note: This indication applies only in territory not equipped with Automatic Block Signals.

Indication: Approach next signal at restricted speed, prepared to stop.

Name: Distant (Caution) Signal.

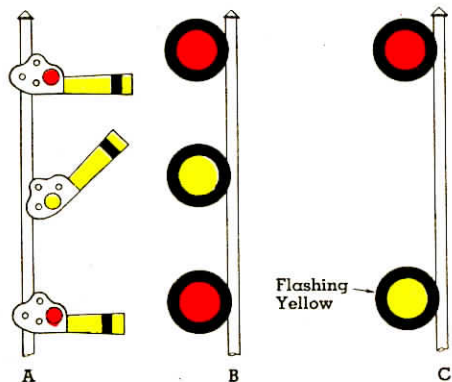

Indication: Proceed at medium speed preparing to stop at next signal.

Name: Medium—Approach.

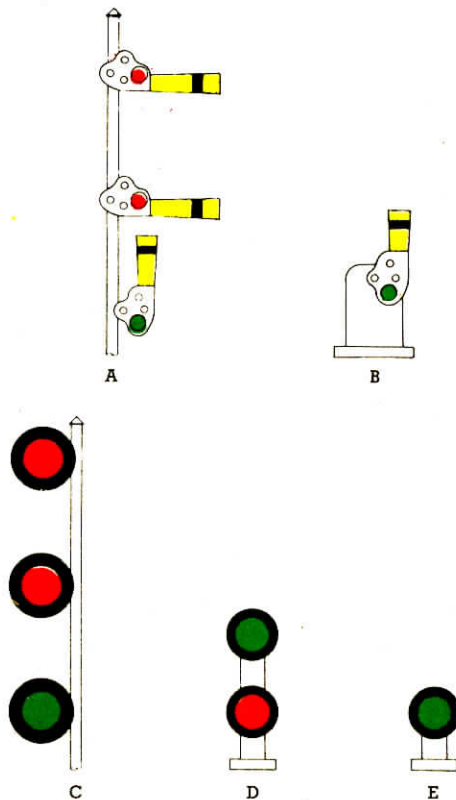

Indication: Proceed: slow speed within Interlocking Limits.

Name: Slow—Clear.

RULE 288

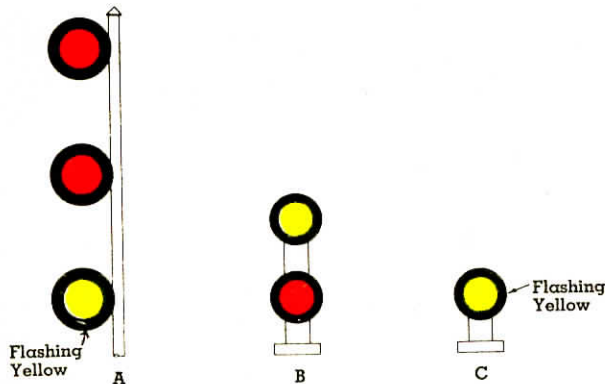

Indication: Proceed preparing to stop at next Signal; slow speed within Interlocking Limits.

Name: Slow—Approach.

RULE 290

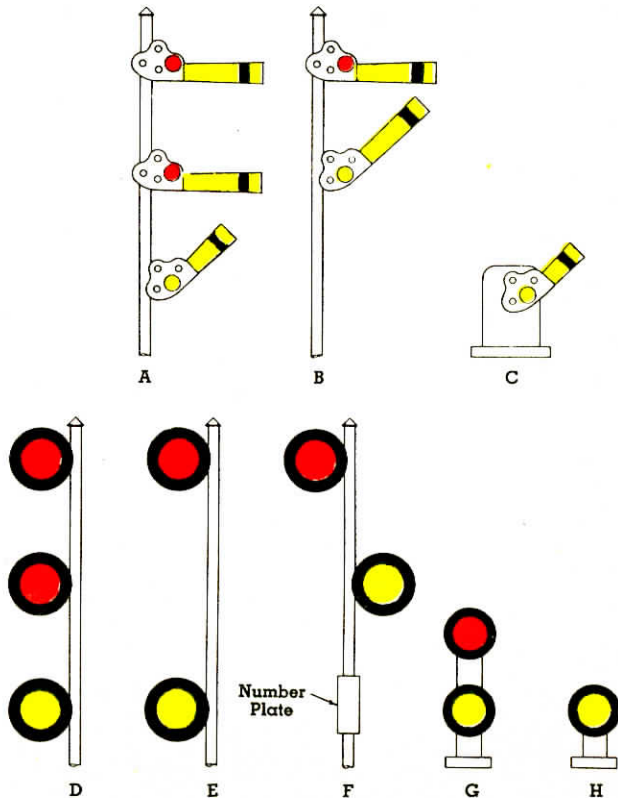

Indication: Proceed at restricted speed.

Name: Restricting.

RULE 291

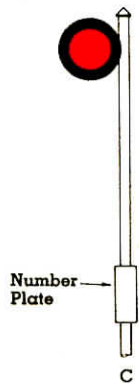
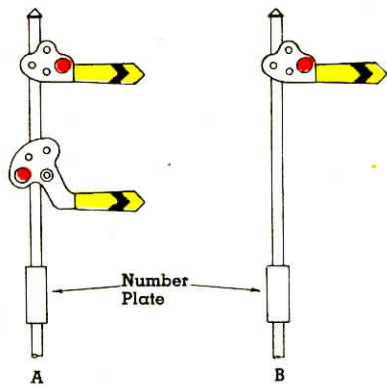

Indication: Stop; then proceed in accordance with Rule 509.

Name: Stop and Proceed.

RULE 292

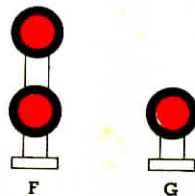
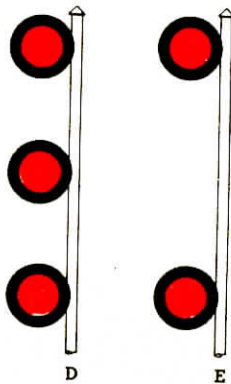
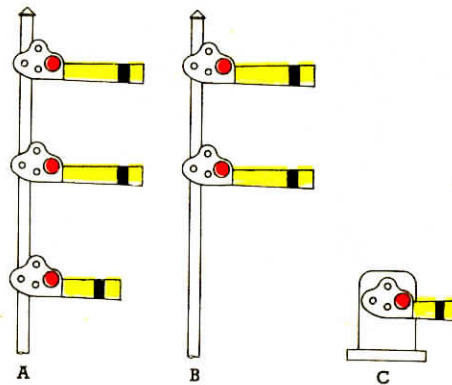

Indication: Stop.

Name: Stop.

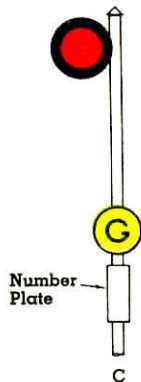
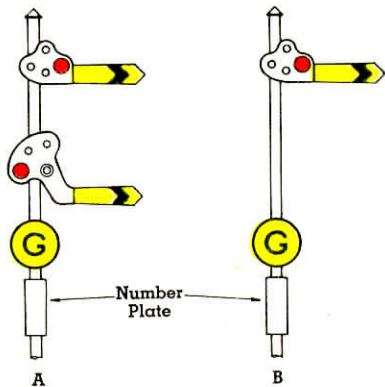

Indication: Stop; then proceed in accordance with Rule 509.

Tonnage freight trains may proceed at Restricted Speed without stopping.

Name: Grade Signal.

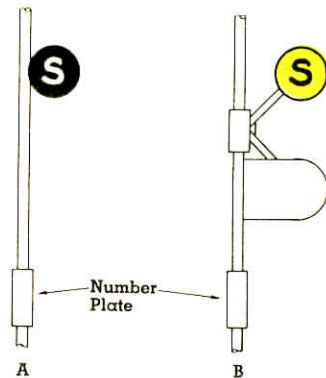

Indication: Take Siding.

Name: Take Siding Indicator.

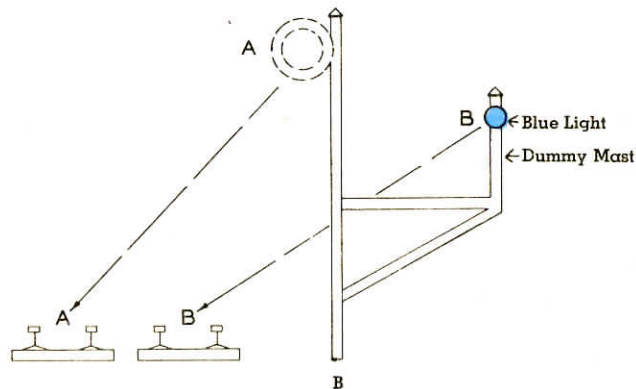
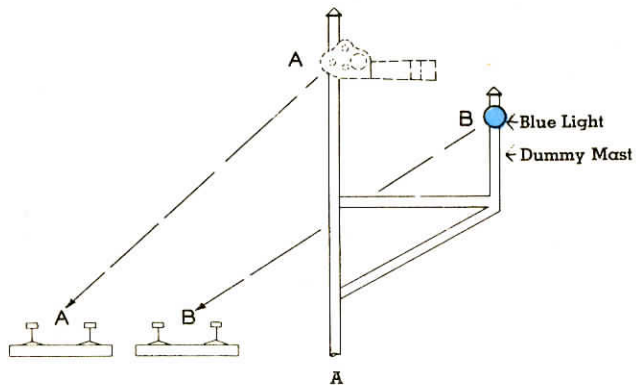

SIGNAL WITH DUMMY MAST

Signal A governs train on Track A. Dummy mast B with Marker Light refers to unsignaled Track B.

DEFINITIONS

- LIMITED SPEED:** A speed not exceeding forty-five miles per hour.
- MEDIUM SPEED:** A speed not exceeding one-half authorized speed, but not exceeding thirty miles per hour.
- SLOW SPEED:** A speed not exceeding fifteen miles per hour.
- RESTRICTED SPEED:** A speed not exceeding that which will enable a train to stop short of train a head, obstruction or switch not properly lined and to look out for broken rail, but not exceeding fifteen miles per hour.

NOTE 1—Speed restrictions apply to entire train.

NOTE 2—Automatic signals are designated by number plate.