

MJL

CLIC BULLETIN NO. 3



CAR

LOCATION

IDENTITY

CODES

INSTRUCTIONS - MAPS

COLORADO DIVISION

SECOND, THIRD

FOURTH, YORK CANYON

and SANTA FE

DISTRICTS

REVISED: MAY 1, 1985

COLORADO DIVISION CLIC BULLETIN NO. 3

<u>Station</u>	<u>Zone</u>	<u>Pages</u>
Second District		
Timpas	10	17
Mindeman	21	17
Delhi	31	18
Simpson	42	19
Model	53	20
Hoehnes	64	20
Trinidad	74	21
Jansen	77	22
Morley	86	22
Wootton	89	23
Lynn	91	23
Keota	92	24
Raton	97	25-26
Third District		
Hebron	09	24
Schomberg	17	27
French	28	28
Springer	38	27
Colmor	48	29
Levy	58	29
Wagon Mound	62	30
Shoemaker	80	30
Watrous	88	31
Onava	96	31
Las Vegas	08	32-33
Fourth District		
Ojita	16	34
Chapelle	27	34
Blanchard	31	35
Sands	41	35
Gise	49	36
Rowe	51	36
Fox	61	37

Glorieta	63	37
Canyoncito	68	38
Lamy	73	39
Waldo	93	40
Domingo	04	41
Nueve	15	40
Bernalillo	24	42

York Canyon District

Colfax	13	28
York Canyon	35	28

Santa Fe District

Santa Fe	18	43-44
----------	----	-------

CAR LOCATION IDENTITY CODES

This booklet contains instructions and maps for the Car Location Identity Code (CLIC) and procedures governing the work order document system.

Maps are not drawn to scale and are to be used only as a guide to locating customer and yard tracks and the numbers assigned to them and in no way circumvents compliance with operating rules and other instructions.

The geographical area covered in this booklet is divided into zones. Each zone has designated tracks and/or industries within its boundary.

A CLIC number will consist of six digits—the first two digits designate the zone; the second two digits indicate the track number within the zone; the last two digits represent the actual spot along the track.

The combination of the zone-track-spot number is known as the 'Car Location Identity Code' (CLIC).

The 'CLIC' number will be used for switching and reporting purposes rather than the industry or track name.

****EXAMPLE OF CLIC NUMBER****

12 22 04

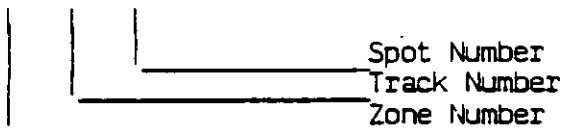

All switch targets or stands have been painted with a combination of the zone and track number.

Spot numbers have been painted on doors, buildings, gates, etc., whenever possible.

WORK ORDER DOCUMENT

A work order document is any written or verbal instruction pertaining to the handling of cars issued to yard or road crews requiring work to be performed during their tour of duty.

NOTE: Exceptions to written work orders must be noted on the work orders according to current instructions; cars handled on verbal work orders must be reported on the prescribed form.

Conductors and Engine Foremen will be furnished work orders during their tour of duty.

This document will specify the cars to be picked up or set out at various stations, industries or interchange tracks serviced by the train or switch job.

Certain information (described below) must be recorded on the work order document by the Conductor or Engine Foreman. Prior to turning in the document at the designated reporting station, it must be dated and signed—even if no work was accomplished. This is necessary to comply with switching and demurrage tariffs, as well as other rules and regulations.

Conductors and Engine Foremen must show on work order cars handled, time and date work performed, CLIC number taken from, CLIC number left at, and appropriate code as listed below:

- BO - Bad Order
- ND - Work Indicated Not Done (State Reason)
- NIT- Car Not in Train, or Not on Track
- OTCC - Car on Track, Carriers Convenience
- OTNP - Car on Track, Not Placed (State Reason)
- PULL - Car Pulled, Time and Date
- SPOT - Car Spotted, Time and Date

Conductor/Engine Foreman must make notation on work order and notify the appropriate employe (S/O, RYO Clerk, Dispatcher, for example) of any exceptions taken to the work order, such as no car, car not on list, car out of line, car is hazardous, excess dimension (when the information is not so indicated on work order), car is carded rear or head end movement, or any other exceptions noted.

If switching is performed without a work order, the Conductor or Engine Foreman must complete the prescribed form showing all the information required above and turn it in at the designated reporting station.

If an industry requests service not shown on work order, Conductor/Engine Foreman should obtain such request in writing. This request is to be turned in with work order for processing. If unable to obtain request in writing, Conductor/Engine Foreman should record on work order the name of the person making request and the service requested and performed.

For observation and guidance, the following codes may appear on work order:

- AI - Agri Industries
- BI - Bad Order
- BA - Blasting Agent (Hazardous)
- BT - Bare Table Flats
- CD - Condemned
- CB - Combustible (Hazardous)
- CG - Cargill
- CL - Chlorine (Hazardous)
- CM - Corrosive (Hazardous)
- DG - Dangerous
- DH - Do Not Hump
- DU - Do Not Uncouple
- EQ - Union Equity or Equity Export-Houston
- FG - Flammable Gas (Hazardous)
- FL - Flammable (Hazardous)
- FS - Flammable Solid (Hazardous)
- FW - Flam. Solid W (Dangerous When Wet)
- HE - Head End Only
- HL - High Wide Load
- HP - Houston Public Elevator
- HV - High Value
- IM - Irritating Material
- IP - Interchange Prohibited
- IPSW - Intraplant Switch (Respot Car)
- LS - Handle In Local Service Only
- MR - Mechanical Refrigeration, Maintain Degrees
- MCNR - Mechanical Car or Trailer--No Refrigeration Required
- ND - Do Not Divert

- NG - Non-Flammable Gas (Hazardous)
- NP - No Placards Required
- OM - Oxidizer (Hazardous)
- OP - Organic Peroxide (Hazardous)
- OX - Oxygen
- PA - Poison Gas (Hazardous)
- PB - Poison
- PE - Houston Public Elevator
- RE - Rear End Only
- RM - Radioactive Material
- REJT - Car Rejected by Shipper
- RSPT - Respot Due to Railroad Error
- TURN - Turn Car & Respot
- WH - Weigh Heavy
- WI - Waive Inspection - Set Direct
- WL - Weigh Light
- XA - Explosive "A"
- XB - Explosive "B"
- XC - Explosives C
- XX - Do Not Move This Car
- ZZ - Cryogenic Liquid

GOOD COMMUNICATION AND COMPLIANCE WITH
INSTRUCTIONS IS ESSENTIAL FOR A COMPLETE
AND SUCCESSFUL OPERATION. YOUR REPORTINGS
ARE THE KEY TO ACCURATE RECORDS.
THE COMPLETE COOPERATION OF EVERY EMPLOYEE
IS SOLICITED.

NUMERICAL INDEX

ZONE 10
TIMPAS, COLORADO

<u>CLIC NO.</u>	<u>NÁME</u>
10 01 00	Siding
10 02 00	Spur Track
10 99 00	Main Track

ZONE 21

MINDEMAN, COLORADO

21 01 00	Siding
21 99 00	Main Track

ZONE 31

DELHI, COLORADO

31 01 00	Siding
31 99 00	Main Track

ZONE 42

SIMPSON, COLORADO

42 01 00	Army Spur
42 02 00	Army Spur
42 03 00	Army Spur
42 04 00	Army Spur
42 05 00	Army Spur
42 06 00	Army Spur
42 07 00	Siding
42 08 00	Spur Track
42 99 00	Main Track

ZONE 53

MODEL, COLORADO

53 01 00	Siding
53 99 00	Main Track

ZONE 64

HOEHNES, COLORADO

64 01 00	Siding
64 02 00	Spur Track

<u>CLIC NO.</u>	<u>NAME</u>	
64 02 01	Spur Team	(Open)
64 99 00	Main Track	

ZONE 74
TRINIDAD, COLORADO

74 01 00	C&S Delivery Track	
74 02 00	C&S Receiving Track	
74 03 00	C&S Connection	
74 04 00	#4 Track	
74 04 01		(Open)
74 04 10		(Open)
74 05 00	Clay Dock Spur	
74 05 01		(Dock)
74 06 00	#6 Track	
74 07 00	Old Rip Track	
74 07 01		(Open)
74 07 10		(Open)
74 08 00	#8 Track	
74 09 00	South House	
74 09 01		(Open)
74 10 00	#11 Spur	
74 11 00	#11 Track	
74 11 01		(Open)
74 12 00	Cleaning Track	
74 12 01		(Open)
74 13 00	North House	
74 13 01		(Open)
74 15 00	Sand Track	
74 15 01		(Open)
74 16 00	Auto Dock Track	
74 16 01		(Open)
74 17 00	Nevada Avenue Spur	(Open)
74 98 00	South Main Track	
74 99 00	North Main Track	

ZONE 77
JANSEN, COLORADO

77 01 00	C&W Transfer	
77 02 00	Derail Track	
77 98 00	South Main Track	
77 99 00	North Main Track	

ZONE 86
MORLEY, COLORADO

<u>CLIC NO.</u>	<u>NAME</u>
86 01 00	Set Out Spur
86 98 00	South Main Track
86 99 00	North Main Track

ZONE 89
WOOTTON, COLORADO

89 01 00	North Spur
89 02 00	South Spur
89 98 00	South Main Track
89 99 00	North Main Track

ZONE 91
LYNN, NEW MEXICO

91 01 00	Set Out Spur
91 99 00	Main Track

ZONE 92
KEOTA, NEW MEXICO

92 01 00	Siding
92 99 00	Main Track

ZONE 97
RATON, NEW MEXICO

97 01 00	Yard Track No. 1	
97 02 00	Yard Track No. 2	
97 03 00	Yard Track No. 3	
97 04 00	Yard Track No. 4	
97 05 00	West No. 5	
97 06 00	Yard Track No. 6	
97 07 00	Yard Track No. 7	
97 08 00	Yard Track No. 8	
97 11 00	House Lead	
97 11 01	Auto Dock	(Dock)
97 12 00	East House	
97 12 01	East House	(Dock)
97 12 10	East House	(Open)
97 13 00	West House	
97 13 01	West House	(Dock)
97 14 00	Texaco Spur	
97 14 01	Mesa Feed	(Doors)
thru 02		

<u>CLIC NO.</u>	<u>NAME</u>	
97 14 10	Texaco	(Dock)
97 15 00	B.T.U. Spur	
97 16 00	Mesa Feed Spur	
97 16 01	Mesa Feed	(Docks)
thru 02		
97 16 03	Mesa Feed	(Door)
97 16 10	Gateway Metal Products	(Door)
97 17 00	Mackie Feed Spur	
97 17 01	Mackie Feed	(Dock)
97 17 10	Mackie Feed	(Dock)
97 18 00	West Leg Wye	
97 18 01		(Open)
97 19 00	East Leg Wye	
97 20 00	Straight Wye	
97 21 00	Caboose Track	
97 22 00	Ramp Track	
97 22 01	Ramp Track	(Ramp)
97 23 00	Rip Lead	
97 24 00	Coal Track	
97 25 00	Raton Builders Spur	
97 25 01	Raton Builders Supply	(Open)
97 98 00	Siding	
97 99 00	Main Track	

ZONE 09

HEBRON, NEW MEXICO

09 01 00	Siding	
09 02 00	Storage Track	
09 99 00	Main Track	

ZONE 17

SCHOMBERG, NEW MEXICO

17 01 00	Siding	
17 99 00	Main Track	

ZONE 28

FRENCH, NEW MEXICO

28 01 00	Siding	
28 02 00	East Leg Wye	
28 03 00	West Leg Wye	
28 04 00	Runaround Track	
28 98 00	York Canyon District Main Track	
28 99 00	Third District Main Track	

ZONE 38
SPRINGER, NEW MEXICO

<u>CLIC NO.</u>	<u>NAME</u>	
38 01 00	House Track	
38 01 01	House	(Dock)
38 01 10	Colfax Mills	(Dock)
38 02 00	Spur	
38 02 01		(Open)
38 03 00	Siding	
38 05 00	Texaco Spur	
38 05 01	Texaco	(Door)
38 99 00	Main Track	

ZONE 48
COLMOR, NEW MEXICO

48 01 00	Siding	
48 99 00	Main Track	

ZONE 58
LEVY, NEW MEXICO

58 01 00	Siding	
58 99 00	Main Track	

ZONE 62
WAGON MOUND, NEW MEXICO

62 01 00	Siding	
62 99 00	Main Track	

ZONE 80
SHOEMAKER, NEW MEXICO

80 01 00	Siding	
80 02 00	Spur	
80 99 00	Main Track	

ZONE 88
WATROUS, NEW MEXICO

88 01 00	Siding	
88 99 00	Main Track	

ZONE 96
ONAVA, NEW MEXICO

96 01 00	Siding	
96 99 00	Main Track	

ZONE 08
LAS VEGAS, NEW MEXICO

<u>CLIC NO.</u>	<u>NAME</u>	
08 01 00	West Leg Wye	
08 01 01		(Open)
thru 02		
08 02 00	East Leg Wye	
08 02 01		(Open)
08 03 00	House #3 Track	
08 03 10	Freight House	(Dock)
08 05 00	Farmway Spur	
08 05 01	Farmway	(Dock)
08 06 00	Company Material Track	
08 07 00	Ramp Track	
08 07 01	Ramp Track	(Ramp)
08 08 00	Malooof Spur	
08 08 01	Joe G. Malooof	(Dock)
08 09 00	Siding	
08 10 00	Yard Track	
08 11 00	Yard Track	
08 12 00	Van Waters & Rogers Spur	
08 13 00	Crossover	
08 14 00	Crossover	
08 99 00	Main Track	
08 15 00	Montana de fibra	(Dock)
08 16 00	Montana de fibra	

ZONE 16
OJITA, NEW MEXICO

16 01 00	Siding	
16 99 00	Main Track	

ZONE 27
CHAPELLE, NEW MEXICO

27 01 00	Siding	
27 99 00	Main Track	

ZONE 31
BLANCHARD, NEW MEXICO

31 01 00	Siding	
31 99 00	Main Track	

ZONE 41
SANDS, NEW MEXICO

<u>CLIC NO.</u>	<u>NAME</u>
41 01 00	Siding
41 02 00	Set Out Spur
41 99 00	Main Track

ZONE 49
GISE, NEW MEXICO

49 01 00	Siding
49 02 00	Set Out Spur
49 99 00	Main Track

ZONE 51
ROWE, NEW MEXICO

51 01 00	Siding
51 99 00	Main Track

ZONE 61
FOX, NEW MEXICO

61 01 00	Siding
61 99 00	Main Track

ZONE 63
GLORIETA, NEW MEXICO

63 01 00	Siding
63 02 00	Set Out Spur
63 99 00	Main Track

ZONE 68
CANYONCITO, NEW MEXICO

68 01 00	Siding
68 02 00	Set Out Spur
68 99 00	Main Track

ZONE 73
LAMY, NEW MEXICO

73 01 00	Siding
73 02 00	Valdez Farms
73 02 01	Valdez Farms (Spout/Port Auger)
73 03 00	Storage Track
73 04 00	Wye Track

<u>CLIC NO.</u>	<u>NAME</u>
73 05 00	Cinder Spur
73 06 00	House Track
73 06 01	House (Dock)
73 98 00	Santa Fe District Main Track
73 99 00	Fourth District Main Track

ZONE 93
WALDO, NEW MEXICO

93 01 00	Siding
93 02 00	Set Out Spur
93 99 00	Main Track

ZONE 04
DOMINGO, NEW MEXICO

04 01 00	Siding
04 02 00	
04 02 01	CC Housing Corporation (Gate)
04 02 02	CC Housing Corporation (Dock)
04 03 00	Rosario Spur
04 04 00	Western Gypsum
04 05 00	Western Gypsum
04 99 00	Main Track

ZONE 15
NUEVE, NEW MEXICO

15 01 00	Siding
15 99 00	Main Track

ZONE 24
BERNALILLO, NEW MEXICO

24 01 00	House Track
24 01 01	House (Open)
24 01 03	(Ramp)
24 01 10	Southwest Forest Ind. (Spout)
24 02 00	Passing Track
24 04 00	New Transfer Track
24 06 00	Team Track
24 06 01	Team (Open)
24 06 02	Hatch Service Corp. Pit w/auger
24 07 00	Gulf Oil Spur - No. 7 Track
24 07 01	Basin Co-op (U.T. Conveyor)
24 07 10	Gulf Oil (U.T. Conveyor)
24 10 00	Standard Oil Spur
24 10 01	Standard Oil (Open)
24 11 00	Plain Electric
24 99 00	Main Track

ZONE 13
COLFAX, NEW MEXICO

<u>CLIC NO.</u>	<u>NAME</u>	
13 01 00	Siding	
13 01 01		(Dock)
13 01 02		(Open)
13 99 00	Main Track	

ZONE 35
YORK CANYON, NEW MEXICO

35 01 00	Runaround Track	
35 01 01	Runaround	(Open)
35 02 00	Mine Track #1	
35 02 01	Mine	(Tipple)
35 99 00	Main Track - Loop	
35 99 01	Loop	(Tunnel)
35 99 02	Loop - Silo #1	(Tipple)
35 99 03	Loop - Silo #2	(Tipple)

ZONE 18
SANTA FE, NEW MEXICO

18 01 00		
18 01 01	Premier Dist.	(Dock)
18 01 10	State Beer Distributors	(Dock)
18 02 00	American Pumice Spur	
18 02 01	American Pumice	(Dock)
18 03 00	Furrow Building Material	Spur
18 03 01	Furrow Building Material	(Dock)
18 04 00	Empire Block Spur	
18 04 01	Empire Block Company	(Dock)
18 05 00		
18 05 01	General Pumice Corp.	(Spout)
18 06 00	State Highway Department	Spur
18 07 00	Big Chief Spur	
18 07 01	Big Chief	(Spout)
18 08 00	Old Indian School Spur	
18 08 01	Texaco Products	(Door)
18 08 10	New Mexico Beverage	(Doors)
thru 11		
18 09 00	Public Service Company	Spur
18 09 01	Public Service Company	(Open)
18 10 00	Spur	
18 10 01		(Door)

<u>CLIC NO.</u>	<u>NAME</u>	
18 10 10	Doxol Propane	(Rack)
18 12 00	Spur	
18 12 01	Wholesale Bldg. Supply	(Doors)
thru 03		
18 12 10	Joe G. Maloof Company	(Door)
18 13 00	Runaround Track	
18 14 00	Southwest Distributing Co. Spur	
18 14 01	Southwest Distributing Co.	(Door)
18 15 00	Runaround Track	
18 16 00	Dock Track	
18 16 01	Dock Track	(Docks)
thru 03		
18 17 00	Team Track	
18 17 01	Team	(Open)
thru 05		
18 18 00		
18 18 01		(Dock)
18 18 02		(Doors)
thru 03		
18 19 00	Storage Track	
18 19 01		
18 20 00	Dock Spur	
18 20 01	Dock Spur	(Dock)
18 21 00	Ramp Track	
18 21 01	Ramp Track	(Ramp)
18 22 00	Engine Track	
18 99 00	Main Track	

53(0)

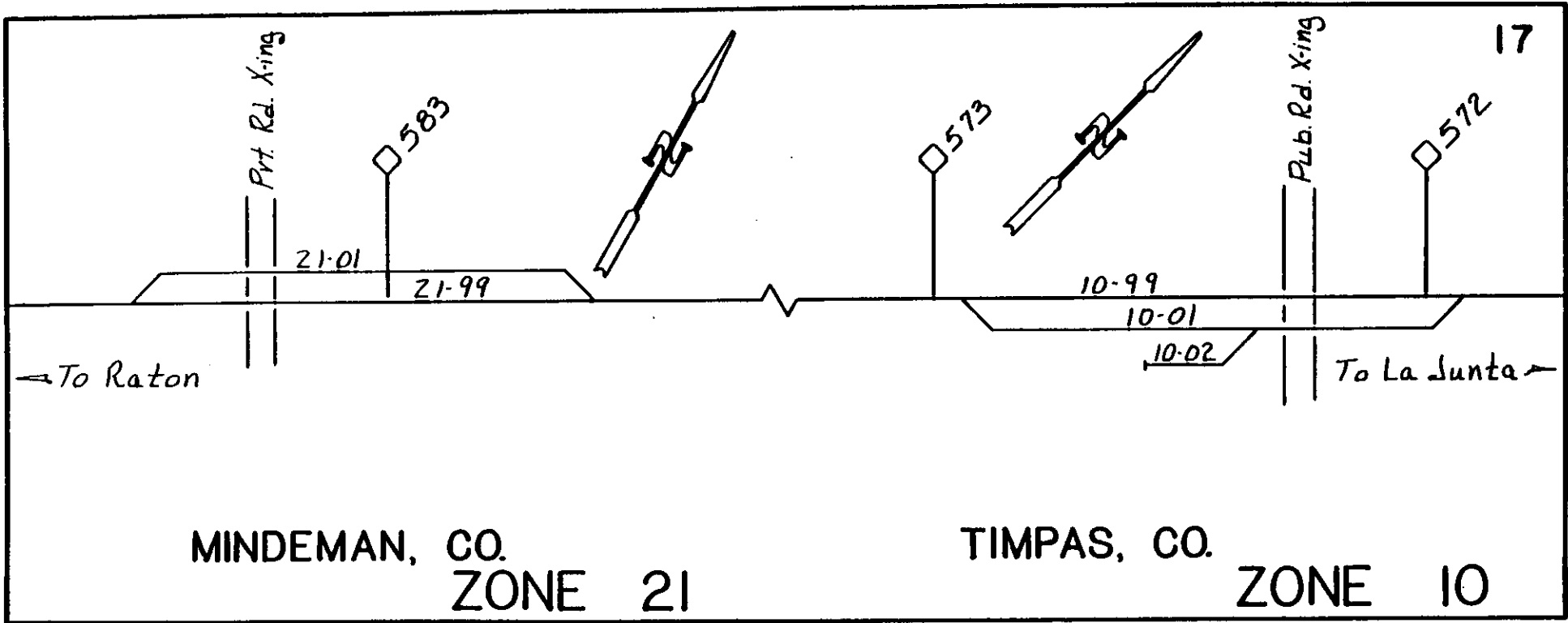

MINDEMAN, CO.
ZONE 21

TIMPAS, CO.
ZONE 10

17

18

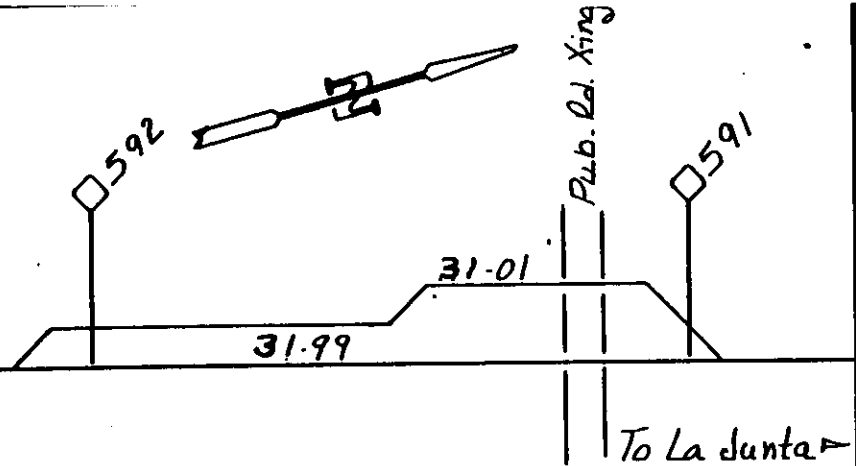

← To Raton

To La Junta →

DELHI, CO.

ZONE 31

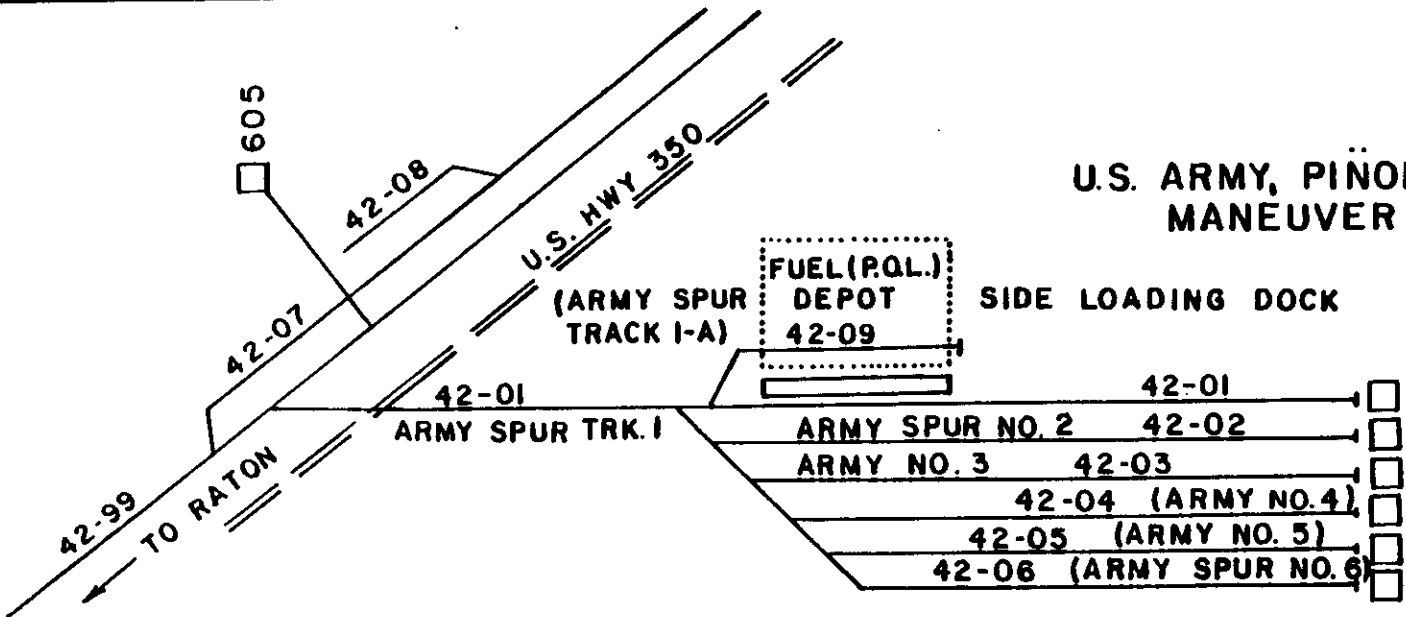

**U.S. ARMY, PIÑON CANYON
MANEUVER BASE**

**END LOADING
T.O.F.C. DOCKS
(STAGING AREA)**

**SIMPSON, CO.
ZONE 42**

20

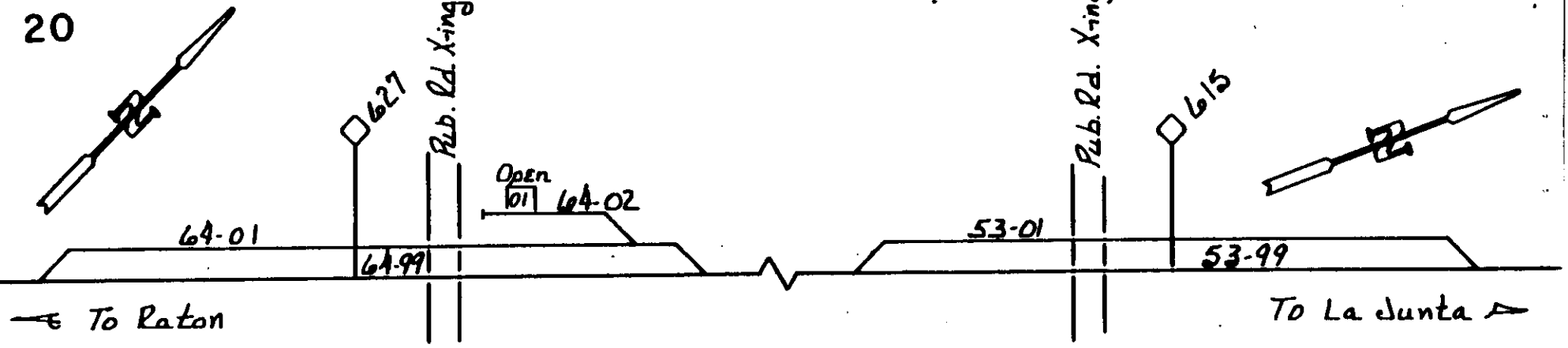

HOEHNES, CO.
 ZONE 64

MODEL, CO.
 ZONE 53

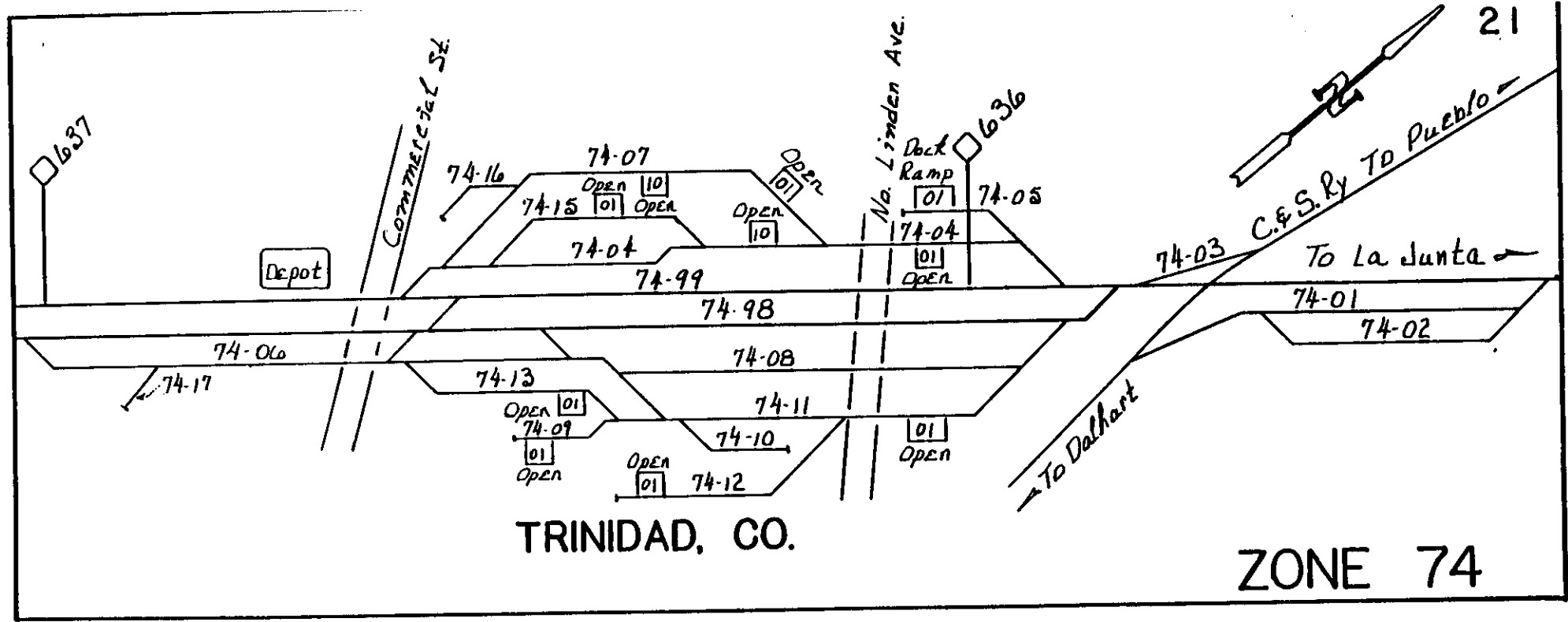

TRINIDAD, CO.

ZONE 74

22

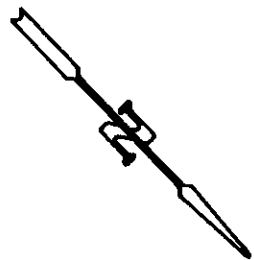

86-99

86-01

648

86-98

639

C&W Ry.

77-01

77-99

77-02

77-98

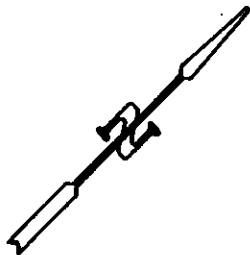

← To Raton

To La Junta →

MORLEY, CO.

ZONE 86

JANSEN, CO.

ZONE 77

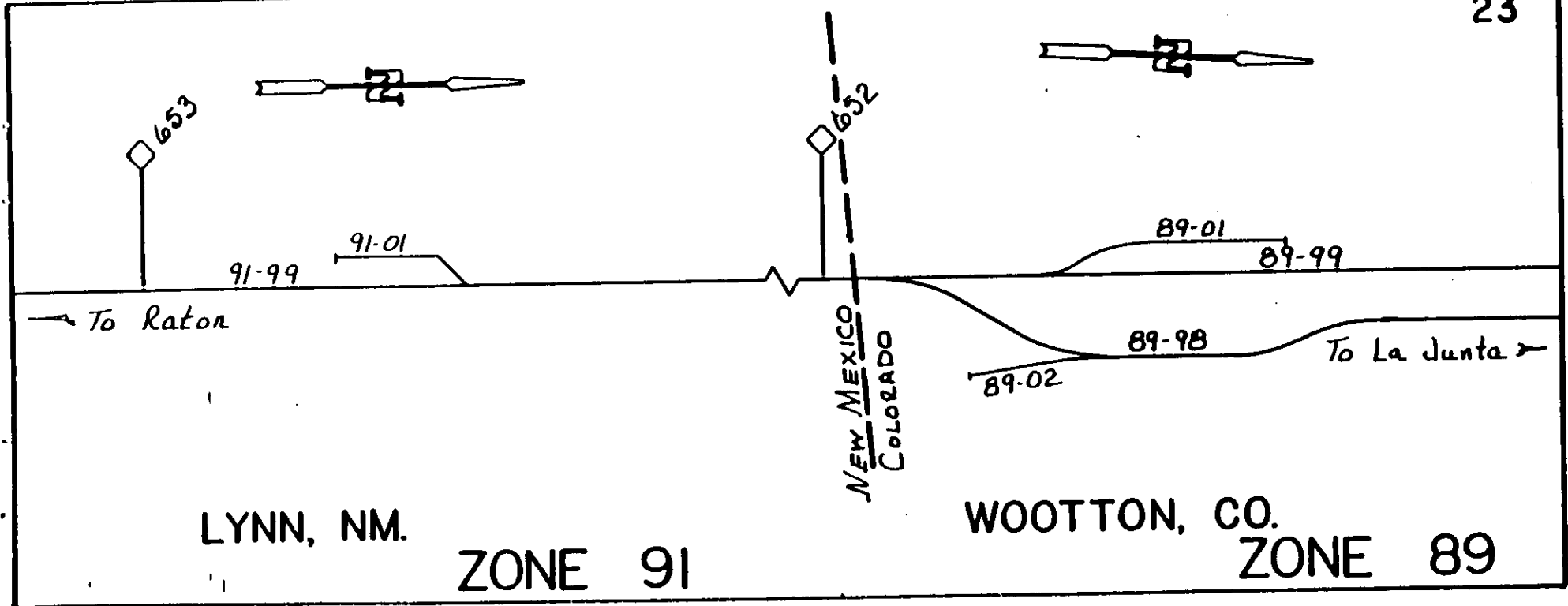

→ To Raton

LYNN, NM.

ZONE 91

NEW MEXICO
COLORADO

WOOTTON, CO.

ZONE 89

To La Junta →

91-99

91-01

89-01

89-99

89-98

89-02

653

652

2

2

24

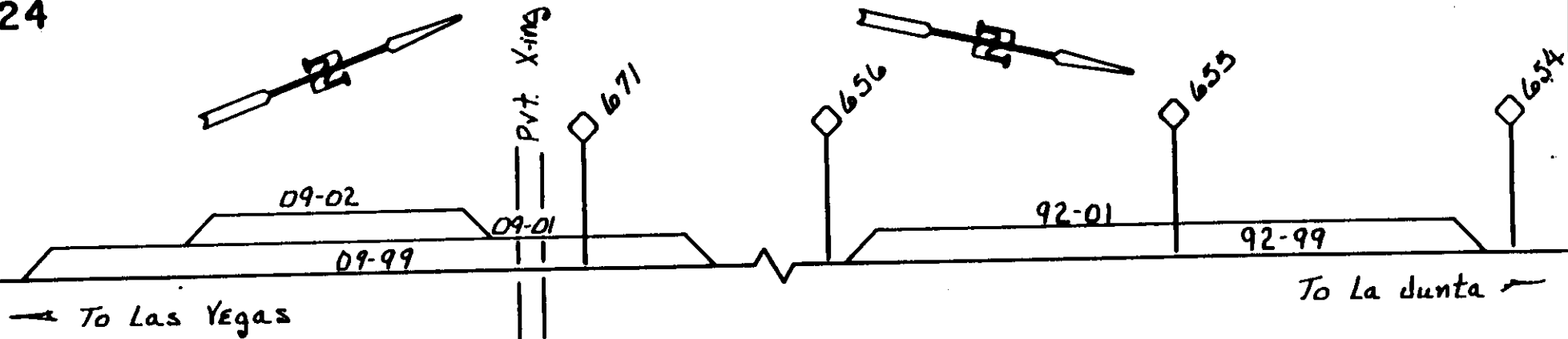

HEBRON, NM.
ZONE 09

KEOTA, NM.
ZONE 92



Gateway
Metal
Products

MESA
FEED

U.S. Hwy 85

Dock 01 02 Door 10 97-16

Door 02 03 Door

Auto
Dock

97-11 01

97-14

97-13 01 Dock

Door 01 Door

97-15

Dock 10

Texaco

660 CO. 2706
ML

Open 10 Dock 01

97-12

97-17 Dock 10 Dock 01

97-05

Depot

To La Junta

Pub. Over Pass

659

114
St. No 114
97-10

To Las Vegas

97-11

97-99

97-98

97-01

97-02

97-25

Open 01

RATON, NM.

ZONE 97

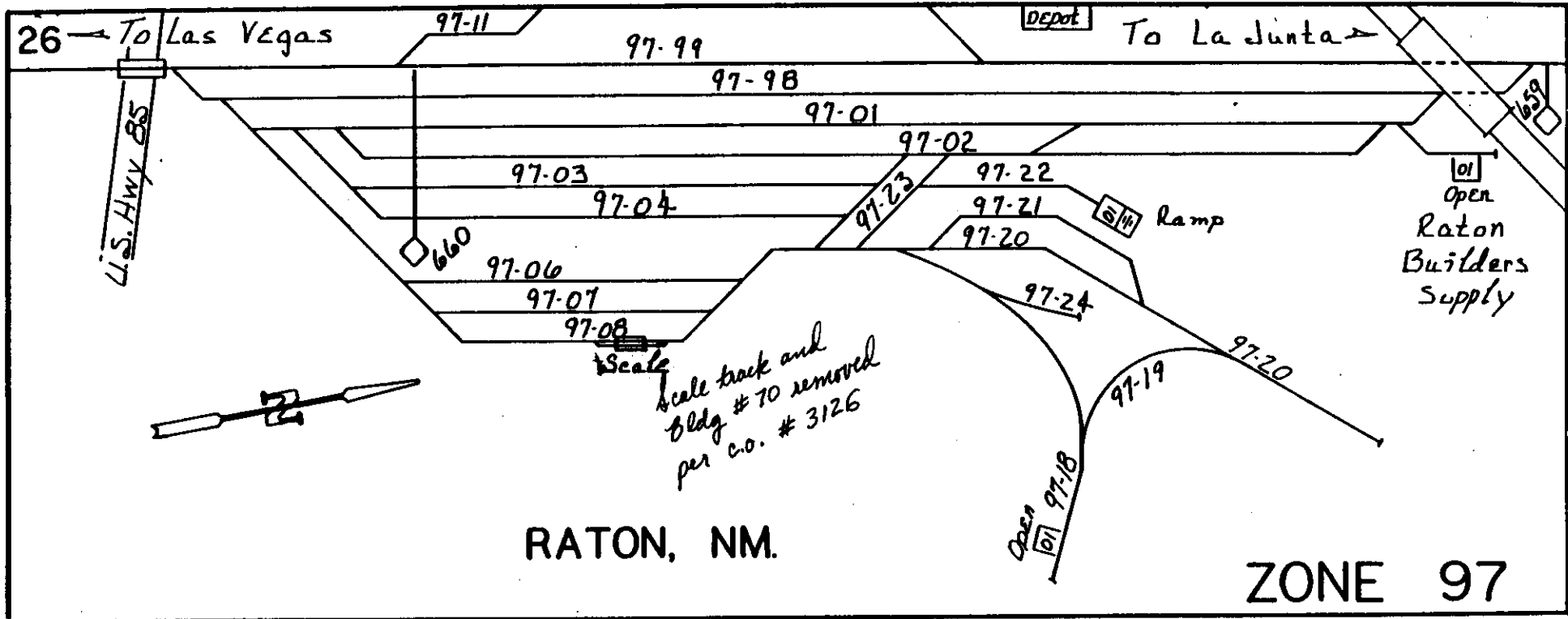

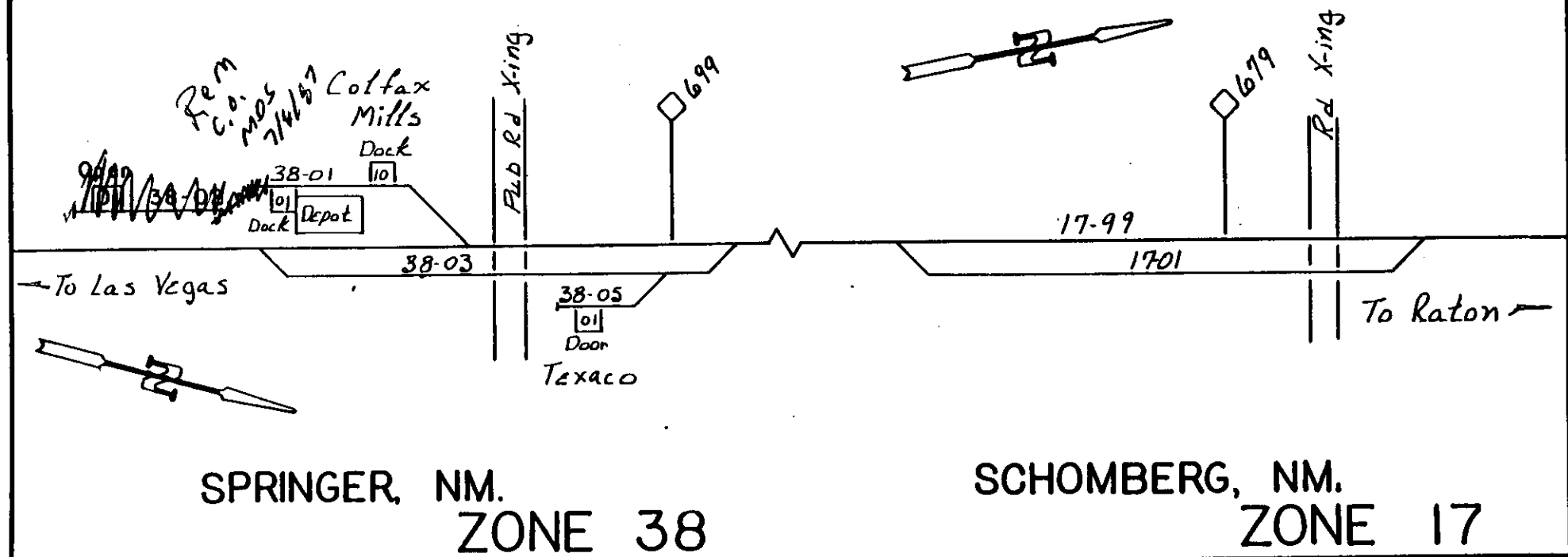

SPRINGER, NM.
ZONE 38

SCHOMBERG, NM.
ZONE 17

28

YORK CANYON DISTRICT

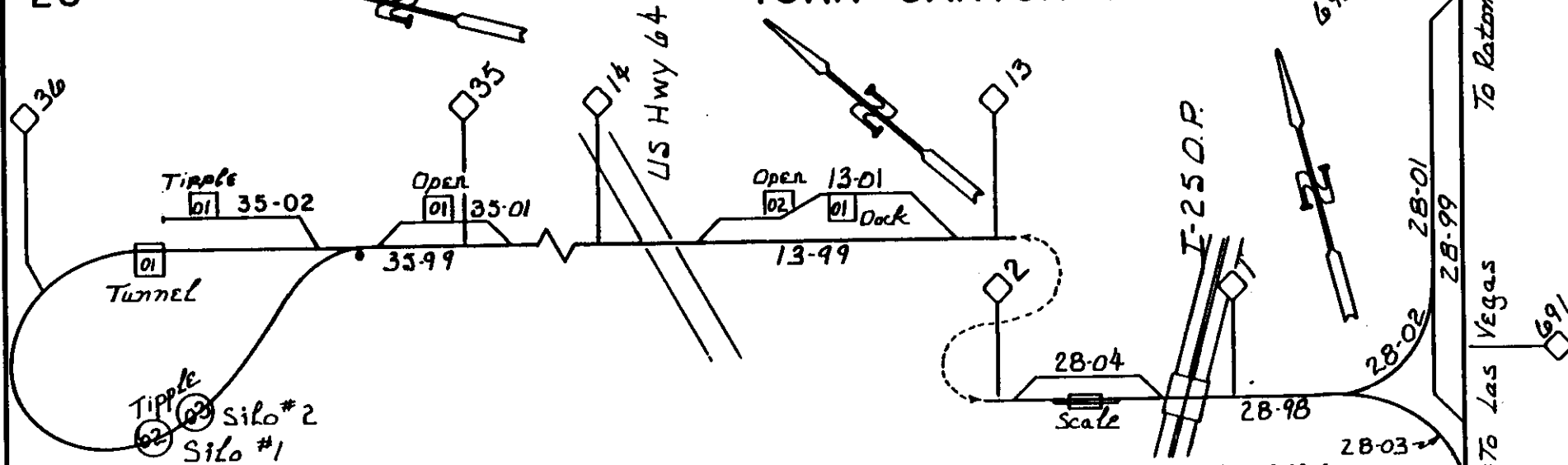

YORK CANYON, NM.
ZONE 35

COLFAX, NM.
ZONE 13

FRENCH, NM.
ZONE 28

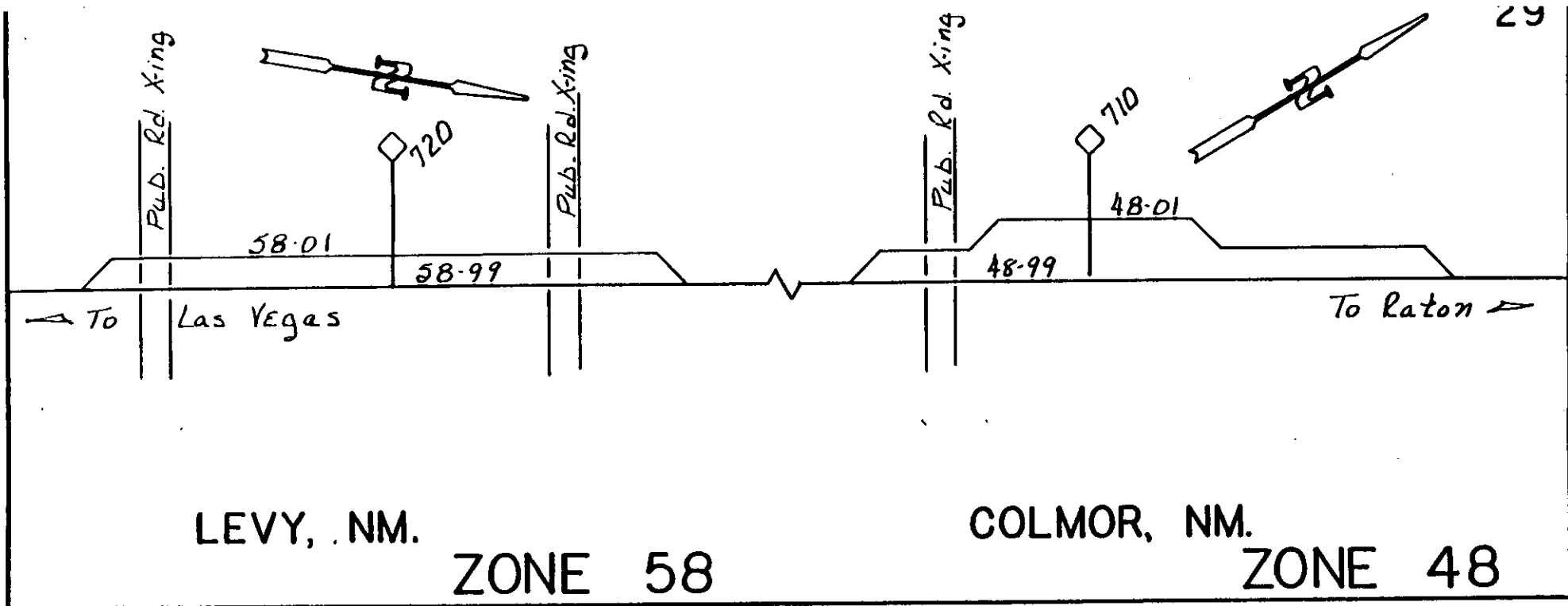

30

Pub. Rd. X-ing

80-02

80-01

742

80-99

726

Pub. Rd. X-ing

62-99

Pub. Rd. X-ing

725

62-01

To Las Vegas

To Raton

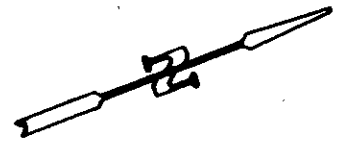

SHOEMAKER, NM.
ZONE 80

WAGON MOUND, NM.
ZONE 62

760

760

No. 1
EXT.

Pub. Rd. X-ing
Co. O.

Mos
7/27/67

96-01

96-99

759

751

88-01

88-99

Pub. Rd. X-ing

750

31

To Las Vegas

To Raton

ONAVA, NM.

ZONE 96

WATROUS, NM

ZONE 88

32

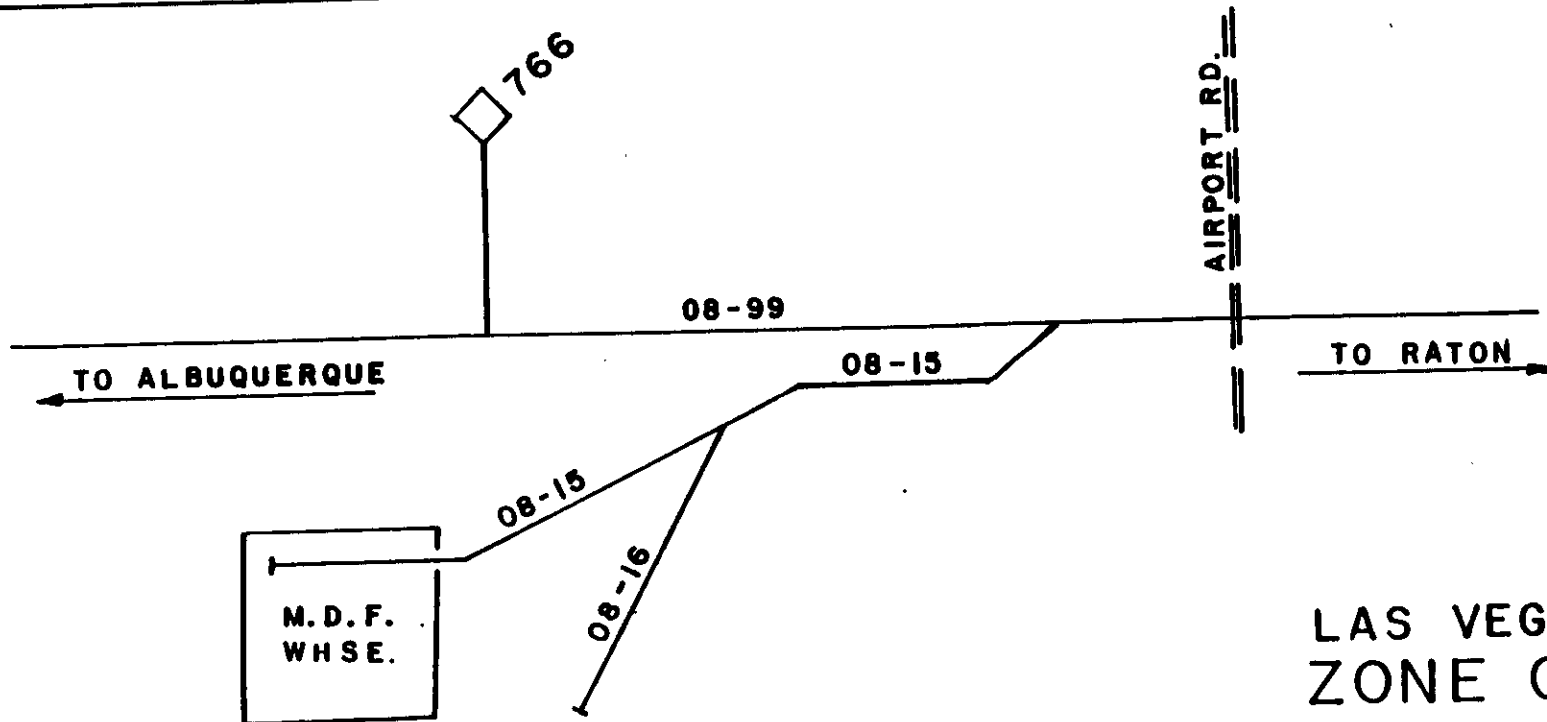

LAS VEGAS, NM.
ZONE 08

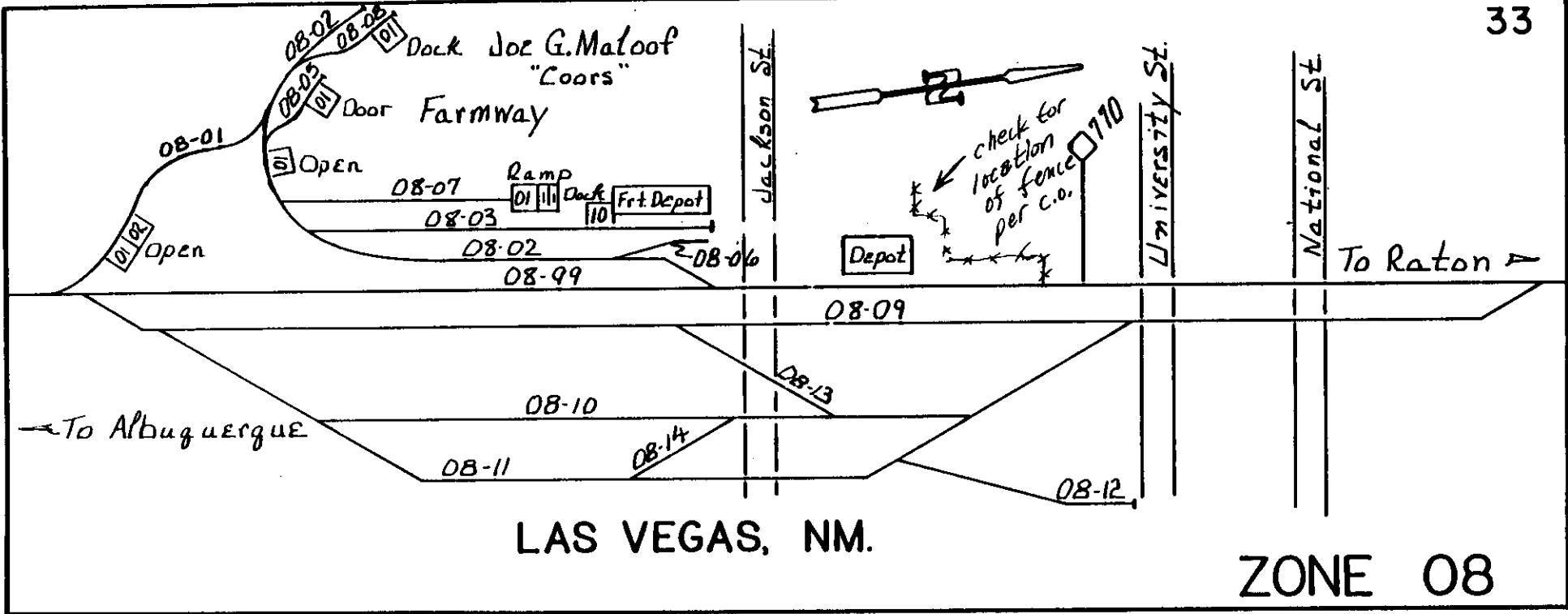

34

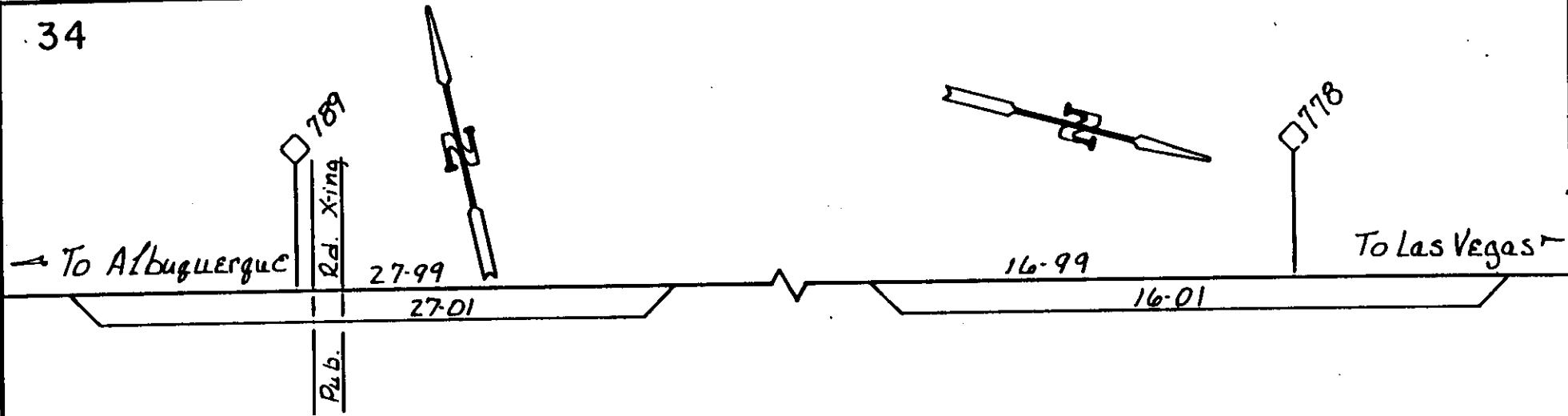

CHAPELLE, NM.
ZONE 27

OJITA, NM.
ZONE 16

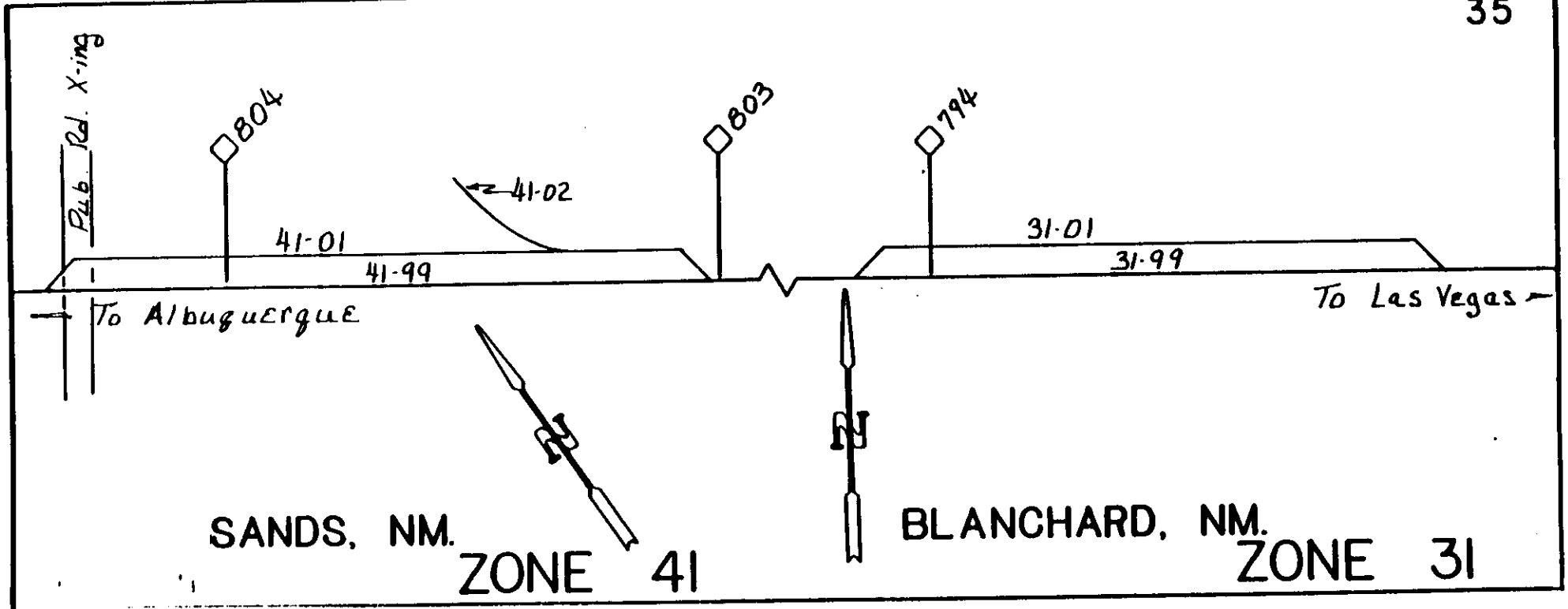

36

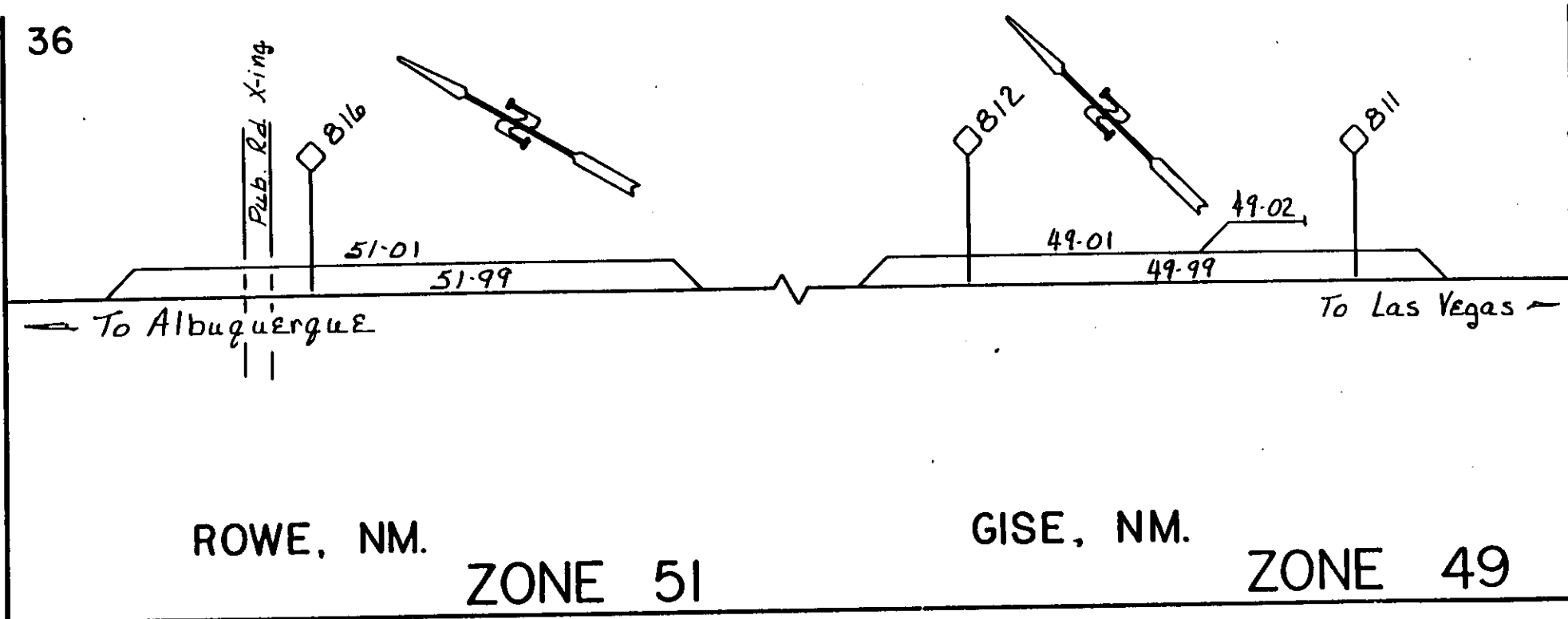

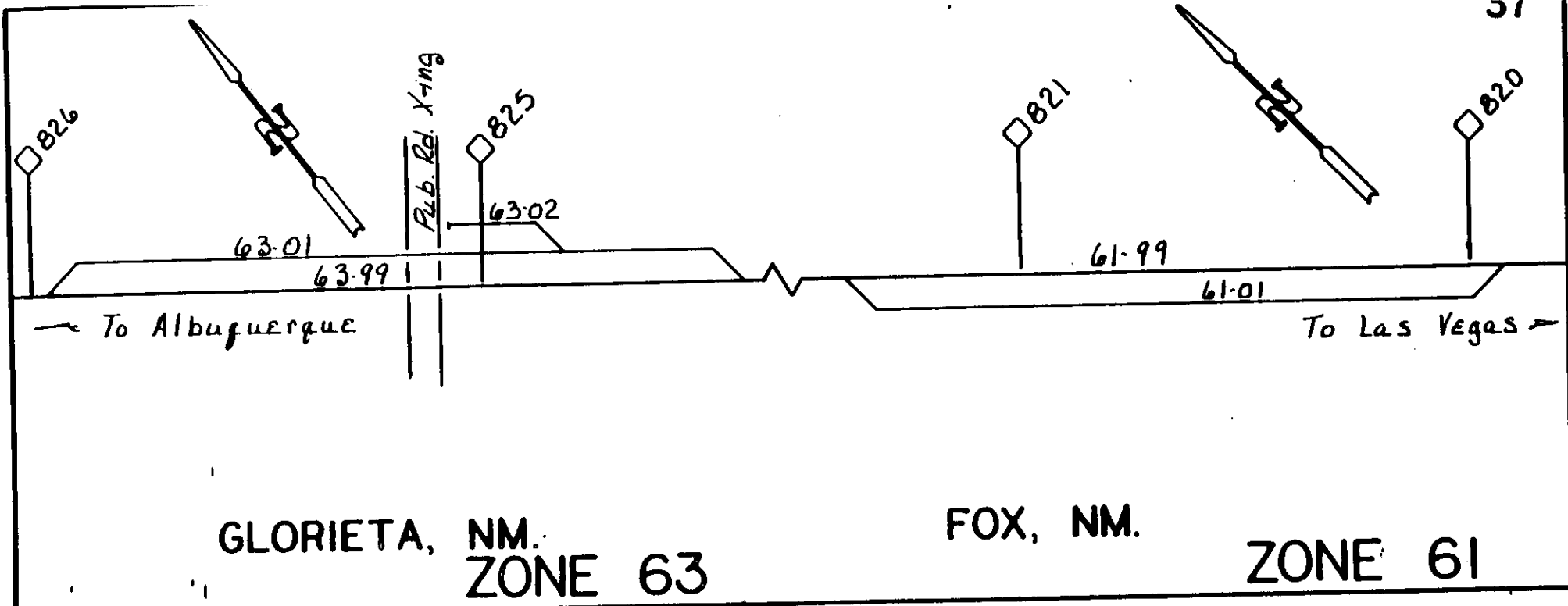

GLORIETA, NM.
ZONE 63

FOX, NM.

ZONE 61

38



68-02

68-01

68-99

→ To Albuquerque

To Las Vegas →

CANYONCITO, NM.
ZONE 68

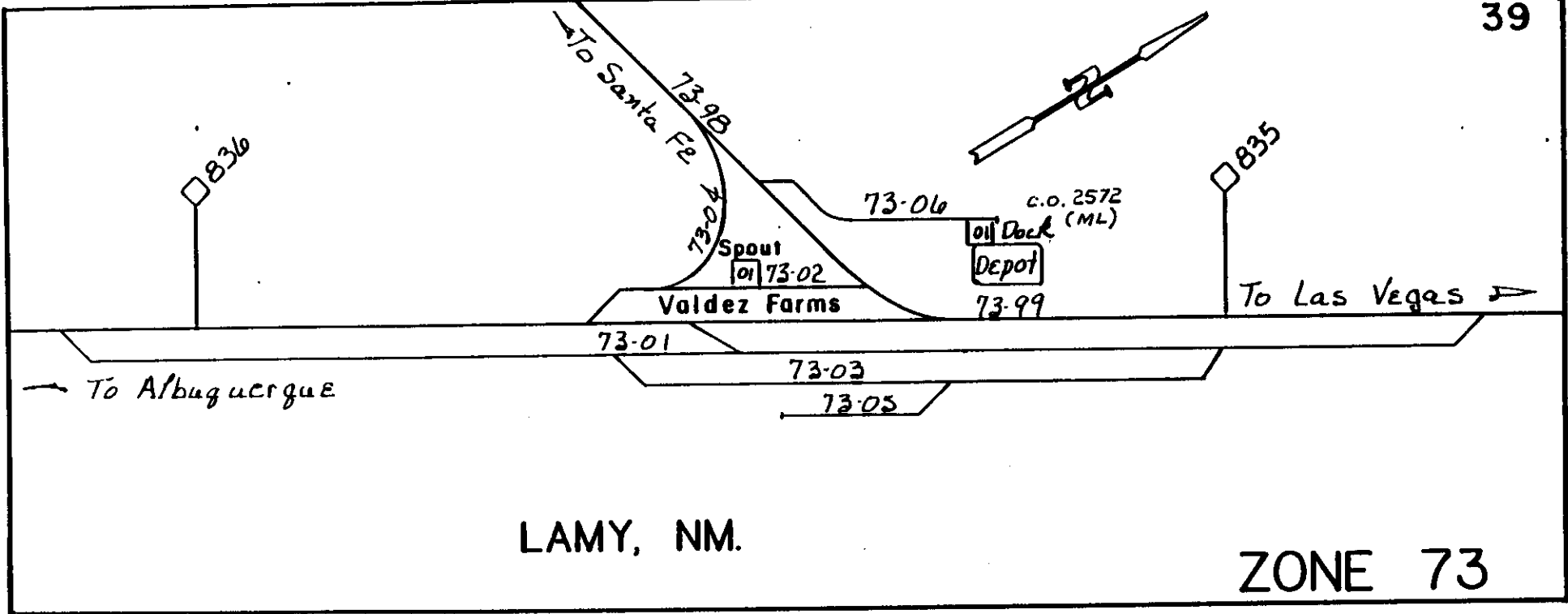

LAMY, NM.

ZONE 73

40

877



866

15-01

15-99

855

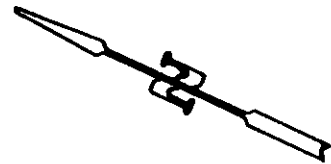

93-99

93-01

834

To Las Vegas

To Albuquerque

93-02

NUEVE, NM.

ZONE 15

WALDO, NM.

ZONE 93

866

CC HOUSING CORPORATION

Gate 01

Dock 02

04-02

Pub. Rd X-ing

04-01

865

861

04-99

To Las Vegas →

← To Albuquerque



DOMINGO, NM.

14-03

WESTERN GYPSUM

04-05

04-04

ZONE 04

42

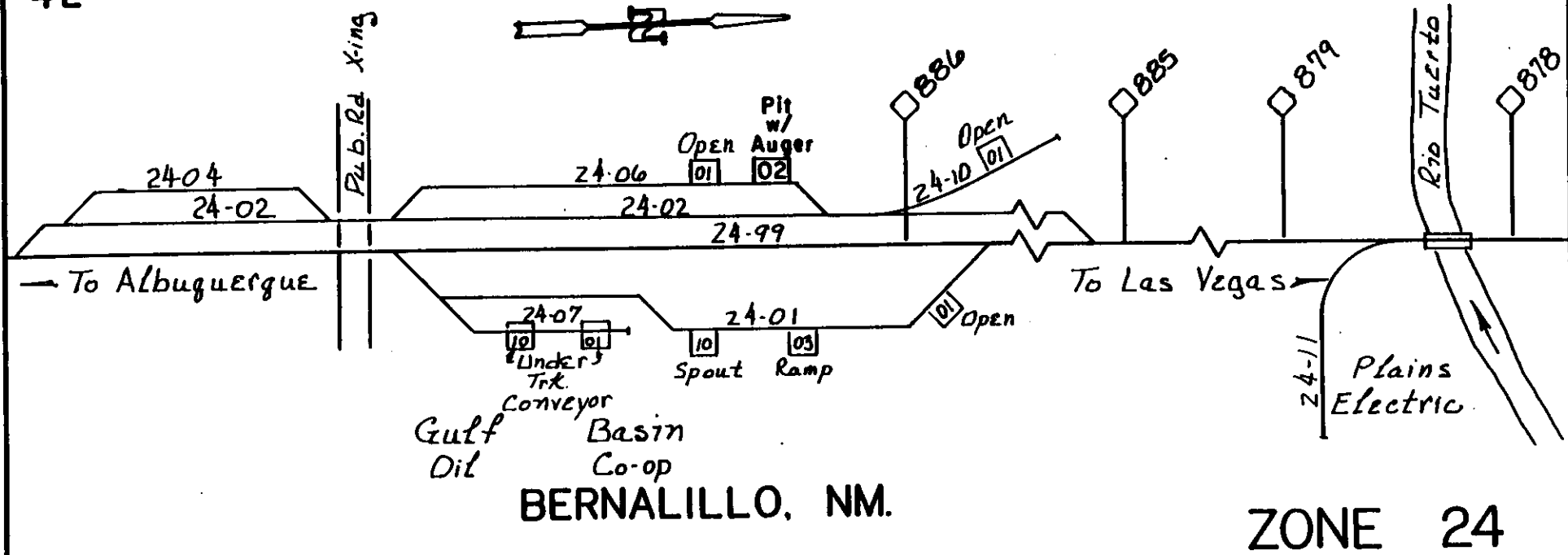

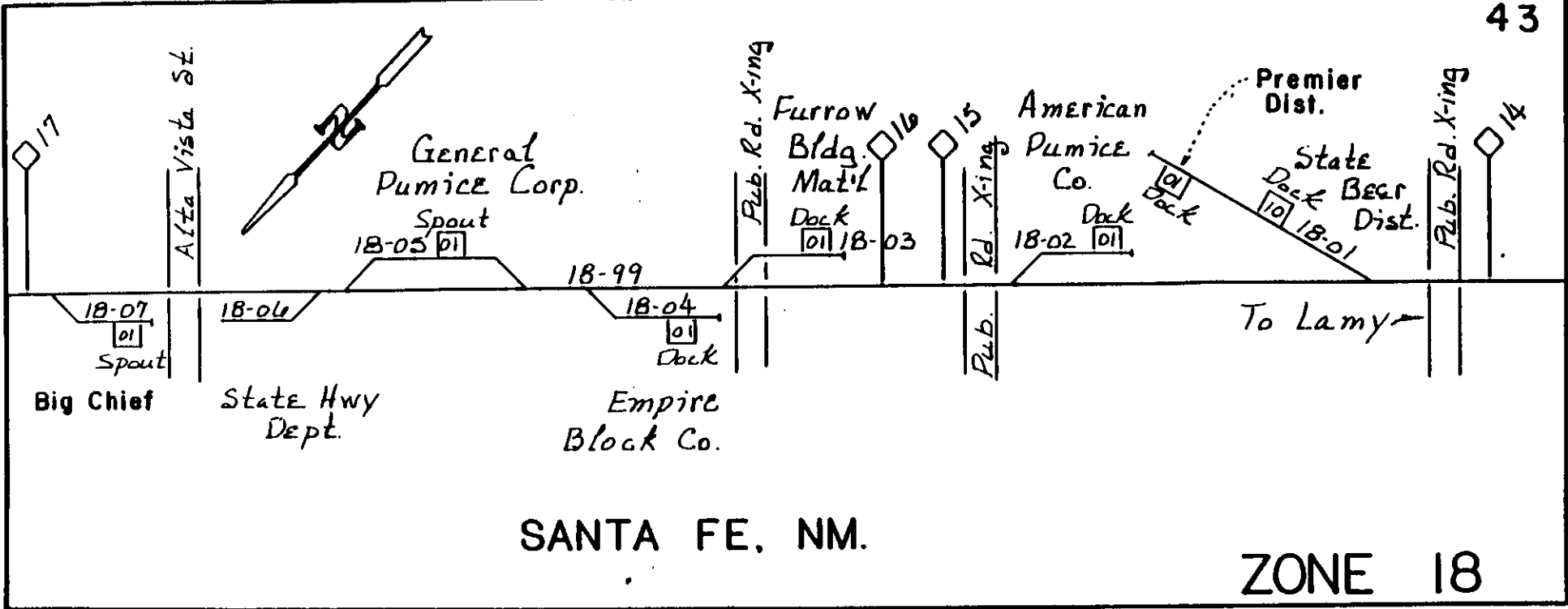

44

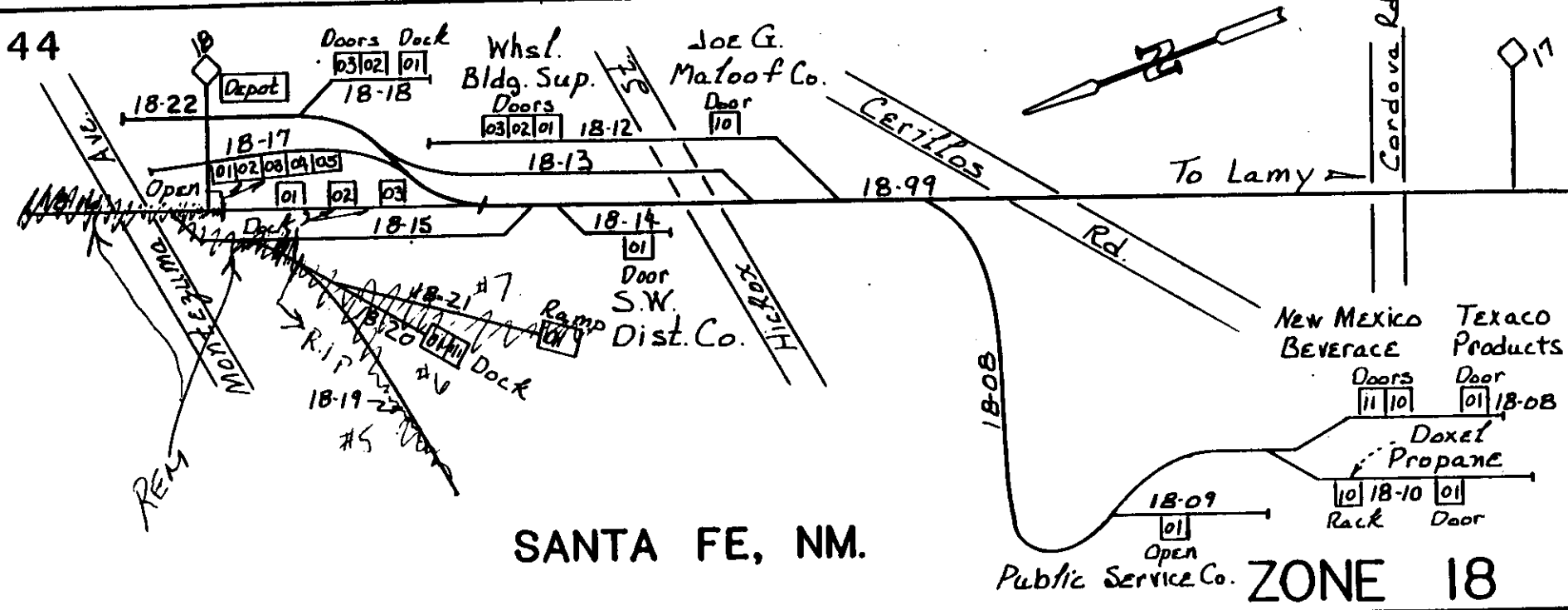

SANTA FE, NM.

ZONE 18

