



**INDUSTRIAL TRACK
NUMBERS
AND**

SPOTTING CODES

VAN BUREN DIVISION

SERVICE UNIT 5

INCLUDING

KANSAS CITY SUBDIVISION

PARSONS, KANSAS

CHEROKEE SUBDIVISION

LABETTE, KANSAS TO WAGONER, OKLAHOMA

JOPLIN SUBDIVISION

OSWEGO, OKLAHOMA TO HORN, OKLAHOMA

COFFEYVILLE SUBDIVISION

COFFEYVILLE, KANSAS TO BARTLESVILLE, OKLAHOMA

TEXOMA DIVISION

SERVICE UNIT 17

INCLUDING

CHEROKEE SUBDIVISION

CHASE, OKLAHOMA TO MUSKOGEE, OKLAHOMA

TULSA SUBDIVISION

WYBARK, OKLAHOMA TO TULSA, OKLAHOMA

CHOCTAW SUBDIVISION

CHECOTAH, OKLAHOMA TO McALESTER, OKLAHOMA

FORMERLY

MKT RAILROAD

NOVEMBER, 1988

FOREWORD

MAPS ON THE FOLLOWING PAGES ARE NOT DRAWN TO SCALE. THEY ARE ISSUED TO SERVE AS A GUIDE IN LOCATING CUSTOMER'S TRACKS AND THE NUMBERS ASSIGNED TO THEM.

THE ZONES ARE DEVELOPED BY CONSOLIDATING ONE OR MORE SWITCHING DISTRICTS OR INDUSTRY ENGINE ASSIGNMENT SERVICE AREAS INTO A ZONE. TWO DIGITS ARE USED TO IDENTIFY A ZONE ON THE MAPS AND ZONE/TRACK LISTING OF INDUSTRIES. IF A ZONE HAS ONLY ONE DIGIT, IT WILL APPEAR AS 01, 02, ETC.

THE TRACK NUMBERING FOR INDUSTRIAL TRACKS WITHIN EACH ZONE WILL BE A THREE DIGIT NUMBER IN SERIES 700-999, WHICH IS ASSIGNED TO EACH AND THE NUMBER PAINTED ON THE SWITCH TARGET, WHERE PRACTICABLE. FOR EXAMPLE, IF THE NUMBER NUMBER 04-700 APPEARS ON A SWITCH LIST, IT WOULD DESIGNATE ZONE 4, TRACK 700.

THE PLACE OR PLACES ON EACH INDUSTRIAL TRACK WHERE A CAR IS SPOTTED FOR LOADING OR UNLOADING IS ASSIGNED A SPOT NUMBER. WHERE MORE THAN ONE CUSTOMER IS LOCATED ON THE SAME

TRACK, THE SPOT NUMBERS WILL IDENTIFY THE INDIVIDUAL CUSTOMER'S LOCATION ON THAT TRACK. THUS, IF A CAR IS TO BE SPOTTED FOR HI-LINE WOOD PRODUCTS, IT WOULD APPEAR AS 04-700-90; THAT IS, ZONE 4, TRACK 700, SPOT 90.

WHEN POSSIBLE, THE SPOT NUMBERS ARE PLACED AT THE CENTER OF THE CAR SPOTS ON THE INDUSTRY TRACKS TO ASSURE PROPER SPOTTING OF THE CAR. WHERE IT IS NOT POSSIBLE TO ACTUALLY PLACE A SPOT SIGN AT SUCH PLACES AS TEAM TRACKS, OPEN AREAS FOR SCRAP OR LUMBER AND OTHER SIMILAR PLACES, A SPOT CODE IS USED. CODES ARE SELF-EXPLANATORY AND APPEAR ON THE FOLLOWING PAGE.

SPOT NUMBERS

- 00 LEAD OR NO SPECIFIC SPOT OR CUSTOMER WILL SUPPLY
- 01-87 FOR SPECIFIC LOADING/UNLOADING PLACES ON INDUSTRIAL TRACKS
- 88 CUSTOMER HAS NOT YET PROVIDED INSTRUCTIONS, CAR CANNOT BE SPOTTED
- 90 OPEN AREA-SCRAP, LUMBER, ETC. SPOTTING
- 91 STORAGE OR HOLD SPOTS
- 92 INSIDE BUILDING SPOTS
- 93 OVERHEAD CRANE SPOTS
- 94 HOPPER/GONDOLA SPOTS FOR GRAVEL, SAND, CEMENT, GRAIN, FLOUR, ETC.
- 95 DOCK OR PLATFORM
- 96 PIGGYBACK RAMP
- 97 BI/TRI LEVEL CAR SPOT
- 98 INTERCHANGE
- 99 TEAM TRACK OR PUBLIC FREIGHT TRACK SPOT

COMPLETING THE WORK

IT IS THE RESPONSIBILITY OF EACH CONDUCTOR OR INDUSTRY JOB FOREMAN TO COMPLETE HIS WORK ORDERS ACCORDING TO 'CONDUCTOR'S INSTRUCTIONS FOR TCS WORK ORDERS', TCS PUBLICATION NUMBER 214, DATED 1 SEPTEMBER 1975. ONCE THESE WORK ORDERS ARE COMPLETED, THE DOCUMENT MUST BE FORWARDED TO THE DESIGNATED OCC EMPLOYEE.

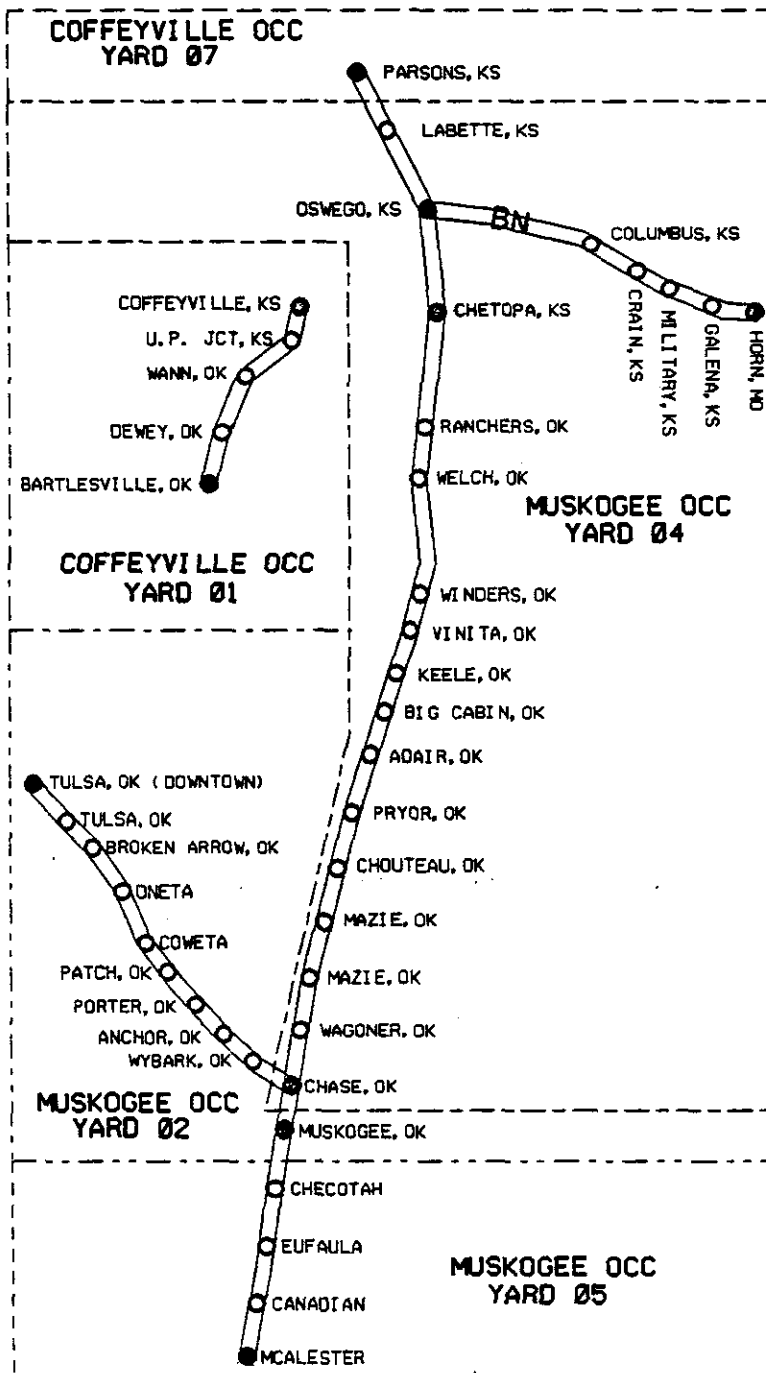

VAN BUREN DIVISION
 SERVICE UNIT 5
 KANSAS CITY SUBDIVISION
 CHEROKEE SUBDIVISION
 JOPLIN SUBDIVISION
 COFFEYVILLE SUBDIVISION

TEXOMA DIVISION
 SERVICE UNIT 17
 CHEROKEE SUBDIVISION
 TULSA SUBDIVISION
 CHOCTAW SUBDIVISION
 NOVEMBER, 1988

MKT/CAL. DGN 1



**VAN BUREN DIVISION
SERVICE UNIT 5
YARD 07
COFFEYVILLE OCC
KANSAS CITY SUBDIVISION**

PARSONS, KANSAS

RMI 36

001-014		EAST 1-14
016		EAST 16
031-041		K 1-11
045		OLD ROUNDHOUSE LEAD
101		KANSAS CITY MAIN
110		SEDALIA MAIN
120		HOUND LEAD
121		BYPASS
122		GOOSE NECK
124		NORTH LEG WYE
125		SOUTH LEG WYE
128		SOUTH YARD LEAD
130		CHEROKEE MAIN
131		OSAGE MAIN
501		NORTH EAST CAB TRACK
503		SOUTH CAB TRACK
601	98	BN CONNECTION
730		GRANDVIEW SPUR (NO SWITCH)
731	99	GARDNER (TEAM TRACK)
732		PARSONS COOP (BECHNER)
735		OLD FOUNDRY TRACK
736-738		HOUSE 1-3
740		DAYTON SUPPLY
741-742		TEC TANK 1-2
743		VALLEY DISTRIBUTOR
745		O E WOOD SPUR
750		JOHNSON GRAIN

**800 & 900 TRACKS LEASED
BY NEOSHO CONSTRUCTION COMPANY**

801		WASH TRACK
802-803		ENGINE TRACKS
806		WEST DUMP
807		EAST DUMP
808		OIL SPUR
810		CRANE TRACK
815		NORTH LEG WYE TO GOOSE NECK
816		FUEL TRACK
817		PRINCESS HOMES
820		ROUNDHOUSE 9
821		ROUNDHOUSE 8
822		ROUNDHOUSE 7.5
823		ROUNDHOUSE 7
824		ROUNDHOUSE 6
825		ROUNDHOUSE 5
826		ROUNDHOUSE 4
827		ROUNDHOUSE 3
828		ROUNDHOUSE 3.5
831		DEAD TRACK
833		RIP 3
834		RIP 2
835		RIP 1
838		WHEEL SPUR
901-903		WEST 1-3
904-907		WEST 4-7 (NO SWITCHES)
908-909		WEST 8-9

TO SEDALIA, MO

TO KANSAS CITY, KS
TO ERIE, KS

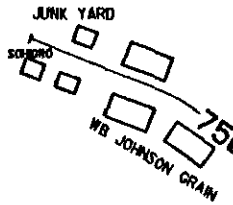

VAN BUREN DIVISION
SERVICE UNIT 5
KANSAS CITY SUBDIV
COFFEYVILLE OCC
DECEMBER, 1988

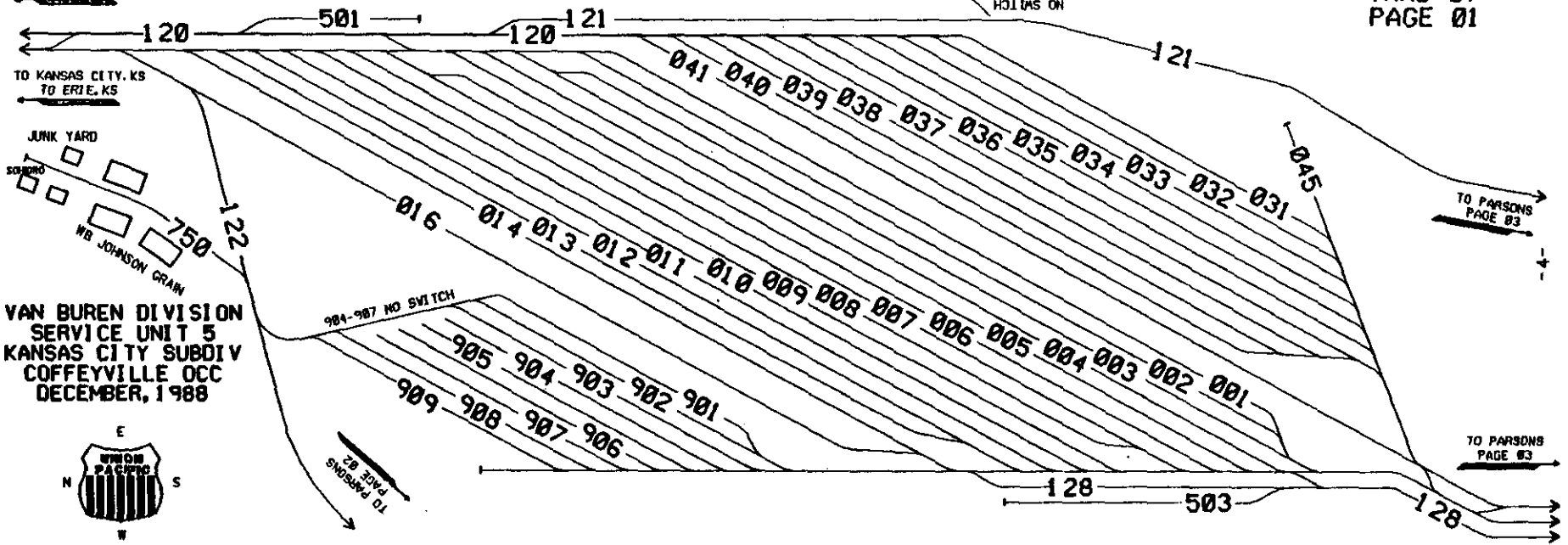

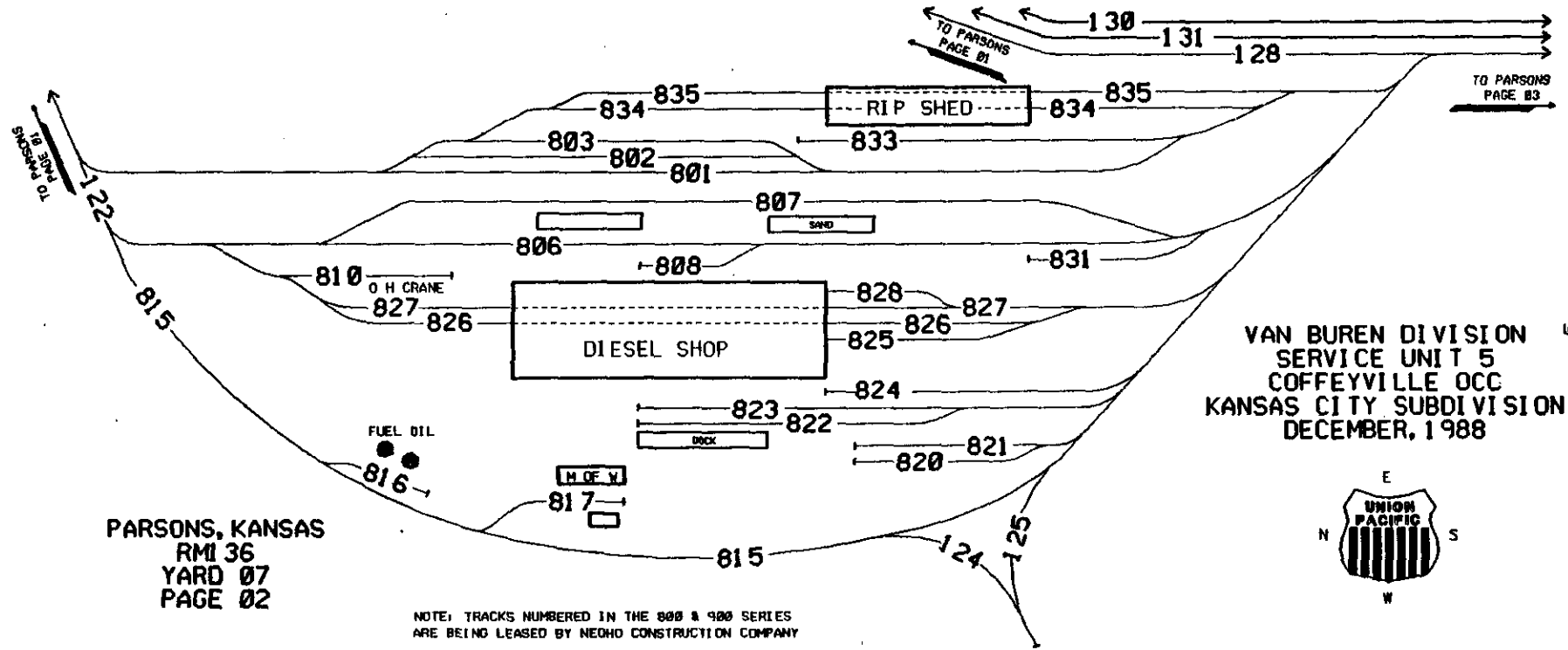

PARSONS, KANSAS
 RMI 36
 YARD 07
 PAGE 02

VAN BUREN DIVISION
 SERVICE UNIT 5
 COFFEYVILLE OCC
 KANSAS CITY SUBDIVISION
 DECEMBER, 1988



NOTE: TRACKS NUMBERED IN THE 800 & 900 SERIES
 ARE BEING LEASED BY NEOHO CONSTRUCTION COMPANY

**VAN BUREN DIVISION
SERVICE UNIT 5
YARD 04
MUSKOGEE OCC
CHEROKEE SUBDIVISION**

LABETTE, KANSAS LM394

101 MAIN LINE
110 LABETTE PASS
111 KANSAS ARMY AMMO PLANT LEAD
701 KAAP KATY INBOUND
702 KAAP KATY OUTBOUND
703 KAAP MAIN TR-2630
704-706 KAAP HOLD *1-3

OSWEGO, KANSAS LM401

101 MAIN LINE
114 NEW BN CONNECTION/JOPLIN SUBDIV
715 FARMERS COOP
716 COONS MANUFACTURING

CHETOPA, KANSAS N 075

101 MAIN LINE
116 CHETOPA PASS
600 98 SEKRR CONNECTION
723 ELEVATOR TRACK
725 99 TEAM TRACK

RANCHERS, OKLAHOMA (FORMERLY LEON) LM420

101 MAIN LINE
728 COAL TRACK

WELCH, OKLAHOMA LM421

101 MAIN LINE
119 WELCH PASS
730 ELEVATOR
732 99 WELCH TEAM TRACK

WINDERS, OKLAHOMA LM438

101 MAIN LINE
122 WINDERS PASS

VINITA, OKLAHOMA LM439

101 MAIN LINE
605 98 BN WEST CONNECTION
735 HOUSE TRACK (NO SWITCHES)

KEELE, OKLAHOMA LM442

101 MAIN LINE
124 KEELE PASS

BIG CABIN, OKLAHOMA LM447

101 MAIN LINE
737 99 BIG CABIN TEAM TRACK

ADAIR, OKLAHOMA LM454

101 MAIN LINE
125 ADAIR PASS
738 99 ADAIR TEAM TRACK

PRYOR, OKLAHOMA LM468

001-004 SMITH YARD *1-4
005 NORTH RUNAROUND
006 DUMP
101 MAIN LINE
127 PRYOR PASS
128 NEW COAL LEAD
129 SOUTH LEG COAL WYE
130 NORTH LEG COAL WYE
132 EAST LEG COAL WYE/LEAD
133 WEST LEG NEW WYE
134 OLD INDUSTRIAL LEAD
135 RALSTON/ROBEL LEAD
136 KAISER/CEMENT LEAD
137 OOW RUNAROUND
138 ESCOA LEAD
139 EAST LEG OLD WYE (OUT OF SERVICE)
140 FOUNDRY LEAD
141 FOUNDRY (GRDA) RUNAROUND
401-402 GRDA TRACKS *1-2 (STORAGE)
404 KAISER RUNAROUND

VAN BUREN DIVISION
 SERVICE UNIT 5
 YARD 04
 MUSKOGEE OCC
CHEROKEE SUBDIVISION

PRYOR, OKLAHOMA CONT:

LM468

740	99	TAPJAC LUMBER (TEAM TRACK)
741		GRDA LOOP
742		GRDA RUNAROUND
743		GRDA STORAGE
744-745		GRDA RIP TRACKS
746		GRDA
747		GRDA TIPPLE
748		GRDA
750		PHILLIPS LEAD
751		PHILLIPS
752		NORTH NEW WYE/PHILLIPS LEASE
753		RED DEVIL
755		A. P. GREEN
756		YARN MILL
757		ATOCHAM RUNAROUND
758		ATOCHAM
759		ROBELL
760		BELCO
761-764		PROTEIN TECH. *1-4
767-770		KAISER *1-4
772		MIDWEST CARBIDE COKE
773		MIDWEST CARBIDE LIME
775		OKLAHOMA CEMENT OUT
776		OKLAHOMA CEMENT IN
778		AIR PRODUCTS
779-780		GEORGIA PACIFIC *1-2
782		ESCOA
784		NATIONAL GYPSUM *1
785		NATIONAL GYPSUM STUB
786		NATIONAL GYPSUM *2
787		N-REN/ST. REGIS *1
788		N-REN SPUR
789		N-REN/ST. REGIS *2
790		POLYCARB SPUR
792		HEAT & POWER SPUR
796		INTERPLASTIC
798		PRYOR FOUNDRY OUT
799		PRYOR FOUNDRY IN

CHOUTEAU, OKLAHOMA

LM472

101	MAIN LINE
801	CHOUTEAU FARM SUPPLY

MAZIE, OKLAHOMA

LM478

101	MAIN LINE
144	MAZIE PASS

LABARGE, OKLAHOMA

LM487

101	MAIN LINE
803	LABARGE TUBULAR

WAGONER, OKLAHOMA

L 242

150	MAIN LINE
151	WAGONER PASS
602	STOCK TRACK (UP CONNECTION)

CHASE, OKLAHOMA

LM499

101	MAIN LINE
146	CHASE PASS

VAN BUREN DIVISION
 SERVICE UNIT 5
 YARD 04
 MUSKOGEE OCC
JOPLIN SUBDIVISION

COLUMBUS, KANSAS

LL419

114 MAIN LINE
 150 COLUMBUS PASS
 608 98 BN CONNECTION
 806 99 TEAM & STORAGE
 807 RICKEL ELEVATOR

CRAIN, KANSAS

LL427

114 MAIN LINE
 152 CRAIN PASS
 809 JAY HAWK SPUR/PBI GORDON

MILITARY, KANSAS

LL429

114 MAIN LINE
 154 NORTH LEG OF WYE
 155 MILITARY PASS
 156 SOUTH LEG OF WYE
 410 STORAGE TRACK
 811-813 OLD RECEIVING YARD #1-3
 815 NORTH LOOP
 816-817 ALCO #1-2
 818, 821 UNKNOWN
 822-827 KOCH CHEMICAL NORTH #1-6
 830-831 KOCH CHEMICAL MIDDLE #1-2
 832 KOCH CHEMICAL SOUTH TRACK
 833 KOCH CHEMICAL SOUTH SPUR
 834-835 KC WASTE STORAGE #1-2
 838 UNKNOWN
 839 UNKNOWN
 840 UNKNOWN

GALENA, KANSAS

LL432

114 MAIN LINE
 613 98 BN CONNECTION & RUNNING
 845 PASS (BLACK DIAMOND)
 846 EAGLE-PITCHER

HORN, MISSOURI

LL433

114 MAIN LINE
 851-854 FARMERS CHEMICAL #1-4

VAN BUREN DIVISION
SERVICE UNIT 5
MUSKOGEE OCC
CHEROKEE SUBDIVISION
NOVEMBER, 1988



LABETTE, KANSAS
LM394
YARD 04
PAGE 01

OSWEGO, KANSAS
LM401
YARD 04
PAGE 01

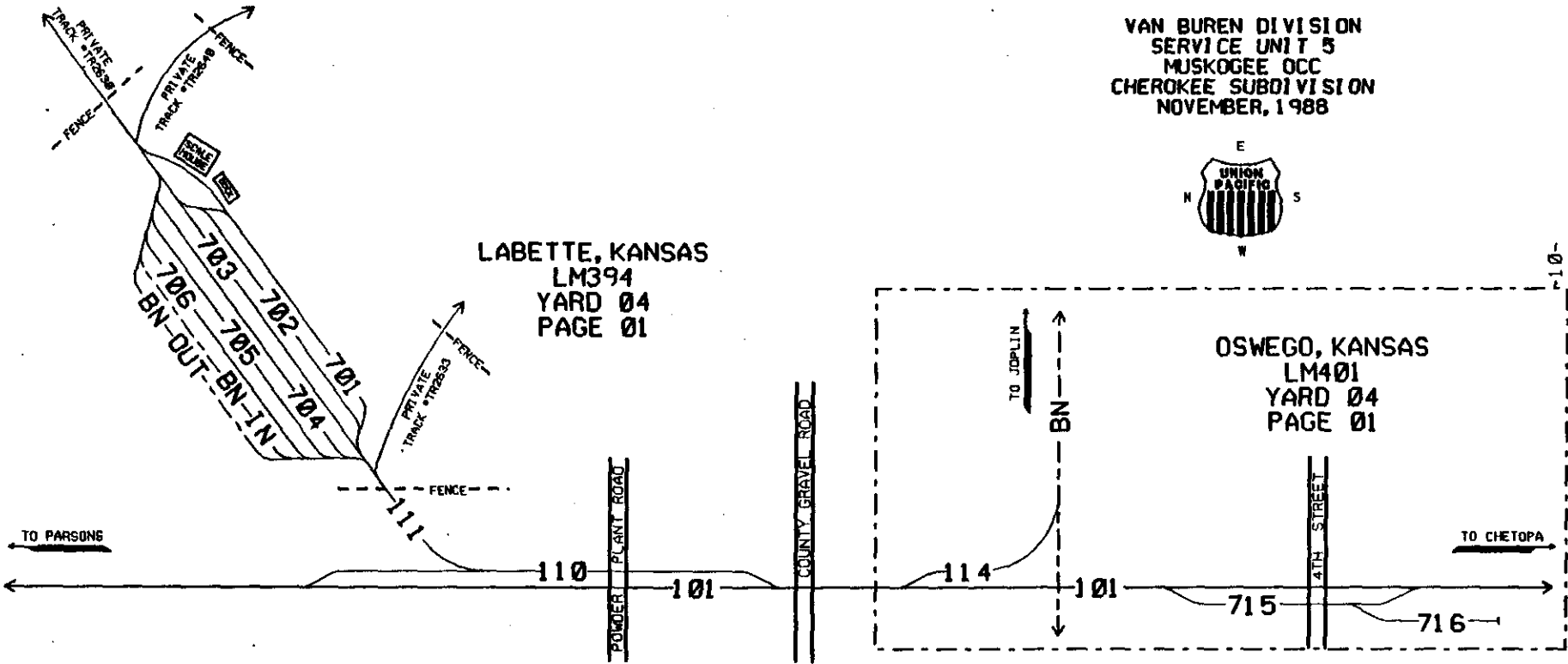

VAN BUREN DIVISION
SERVICE UNIT 5
MUSKOGEE OCC
CHEROKEE SUBDIVISION
NOVEMBER, 1988

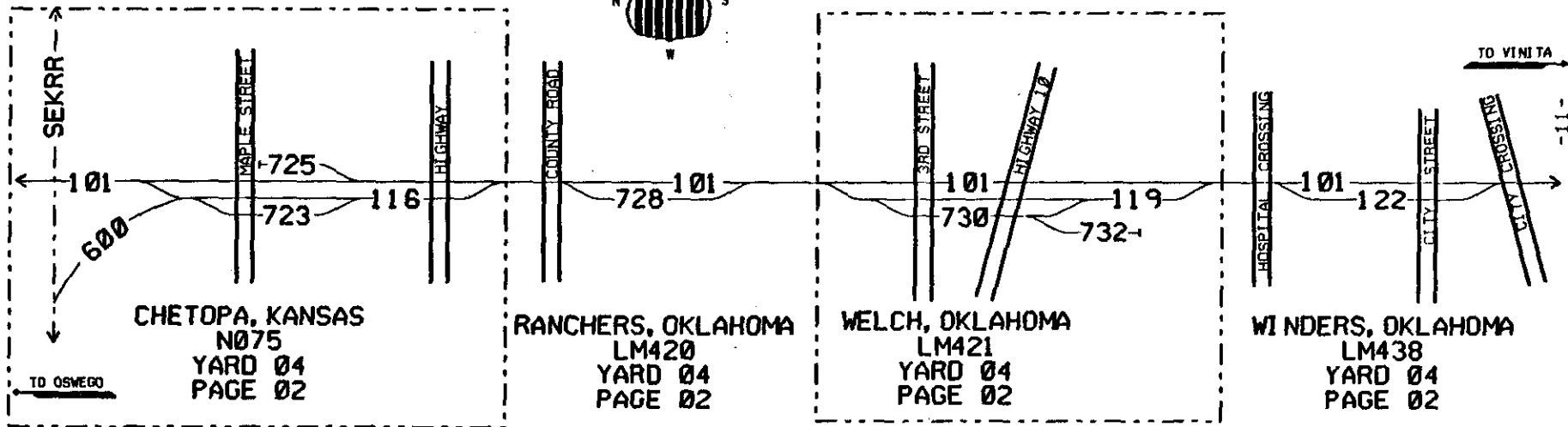
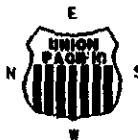

VAN BUREN DIVISION
 SERVICE UNIT 5
 MUSKOGEE OCC
 CHEROKEE SUBDIVISION
 NOVEMBER, 1988

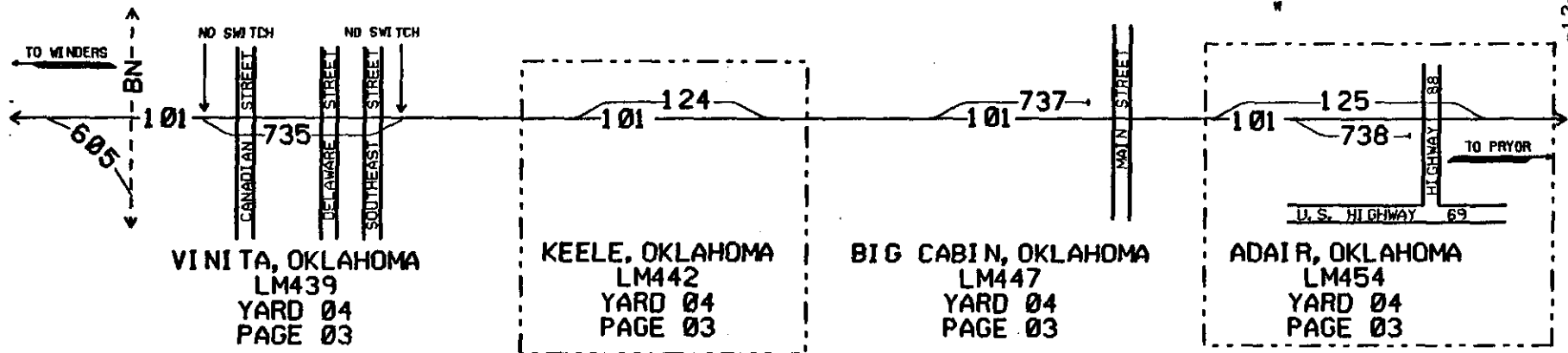

PRYOR, OKLAHOMA
LM468
YARD 04
PAGE 05

VAN BUREN DIVISION
SERVICE UNIT 5
MUSKOGEE OCC
CHEROKEE SUBDIVISION
NOVEMBER, 1988

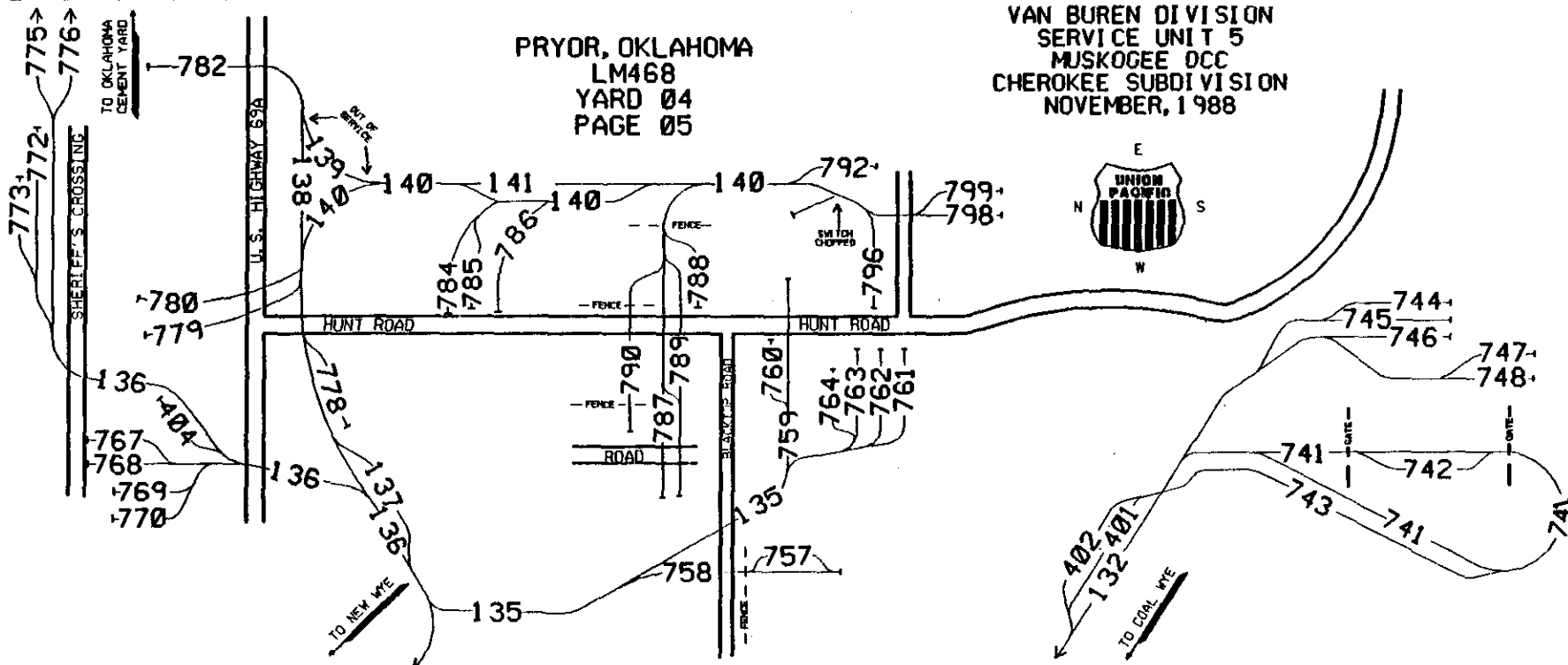

VAN BUREN DIVISION
 SERVICE UNIT 5
 MUSKOGEE OCC
 CHEROKEE SUBDIVISION
 NOVEMBER, 1988

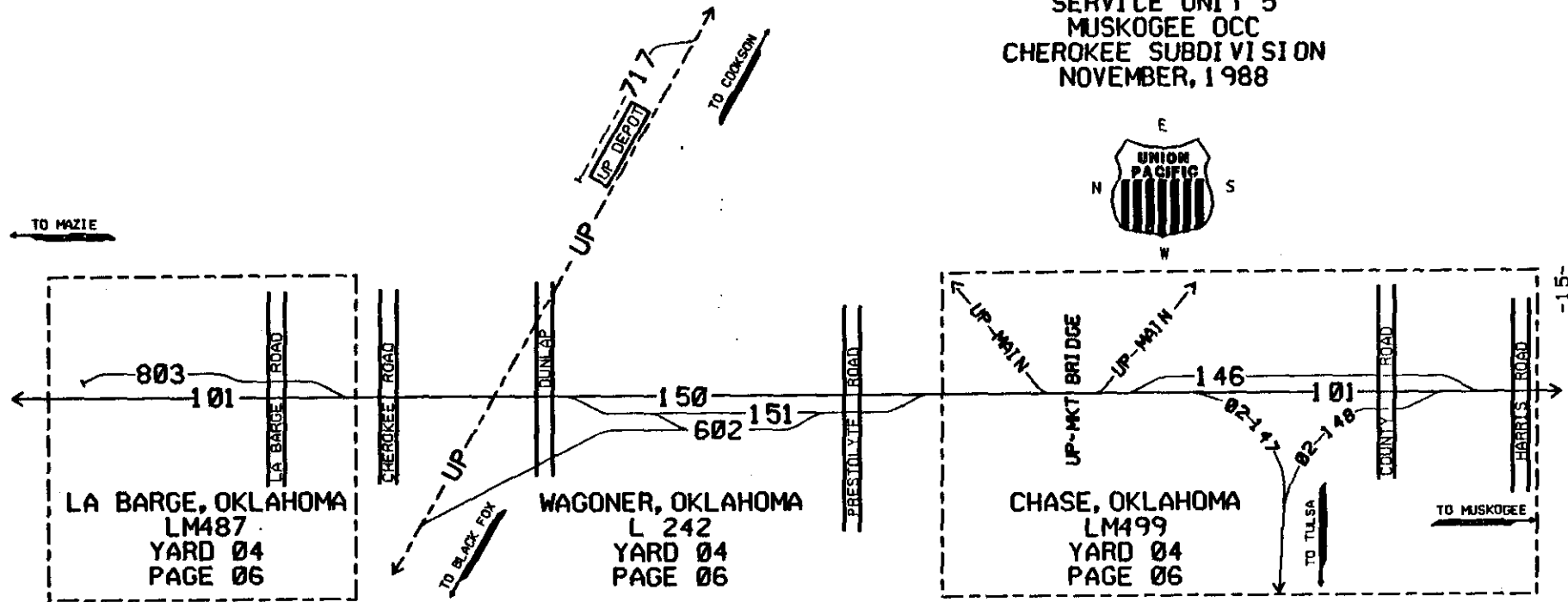

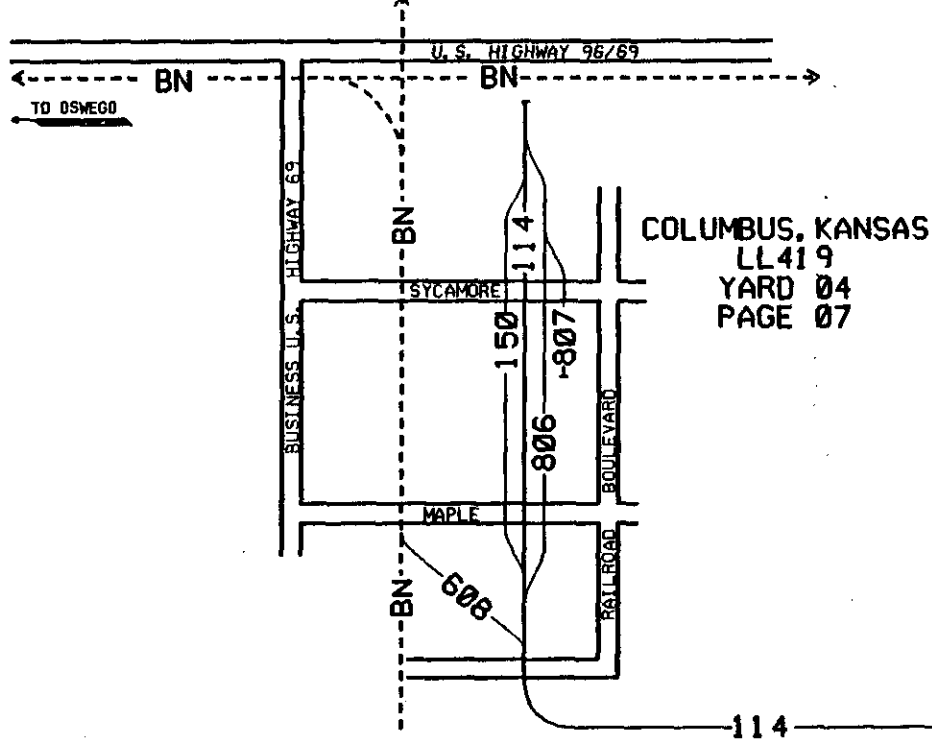

VAN BUREN DIVISION
SERVICE UNIT 5
MUSKOGEE OCC
JOPLIN SUBDIVISION
NOVEMBER, 1988

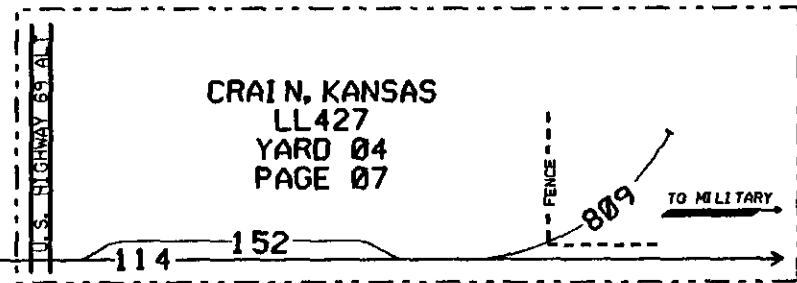

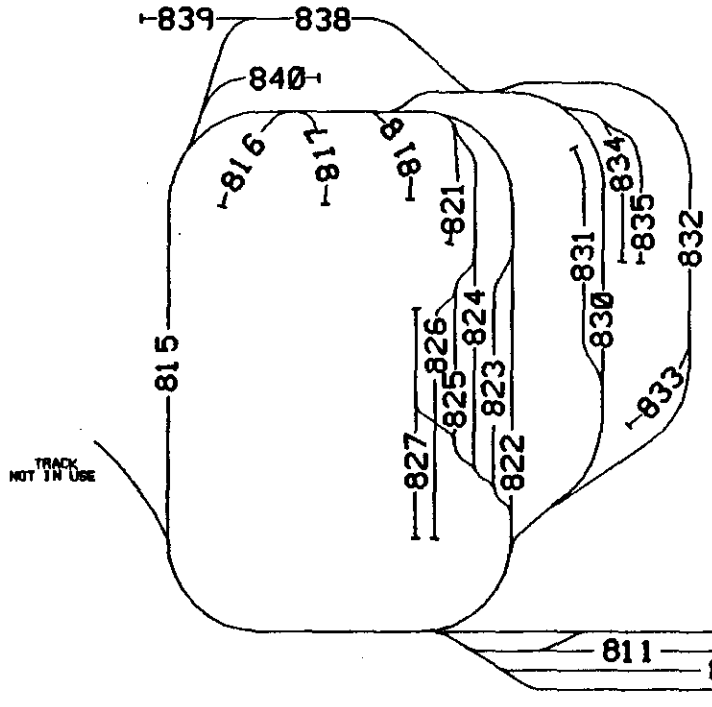

VAN BUREN DIVISION
 SERVICE UNIT 5
 MUSKOGEE OCC
 JOPLIN SUBDIVISION
 NOVEMBER, 1988

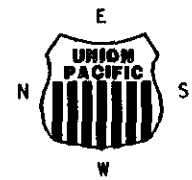

MILITARY, KANSAS
 LL429
 YARD 04
 PAGE 08

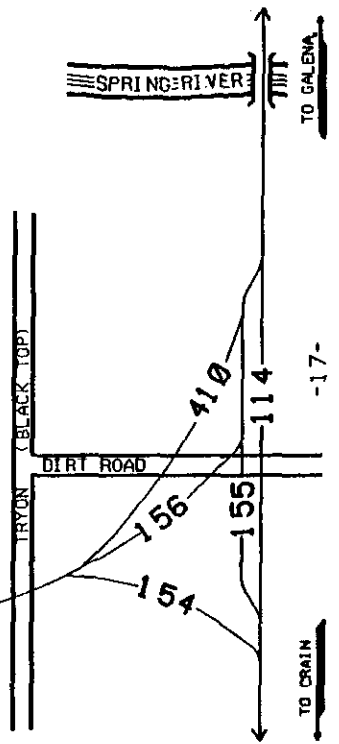

VAN BUREN DIVISION
SERVICE UNIT 5
MUSKOGEE OCC
JOPLIN SUBDIVISION
NOVEMBER, 1988



GALENA, KANSAS
LL 432
YARD 04
PAGE 09

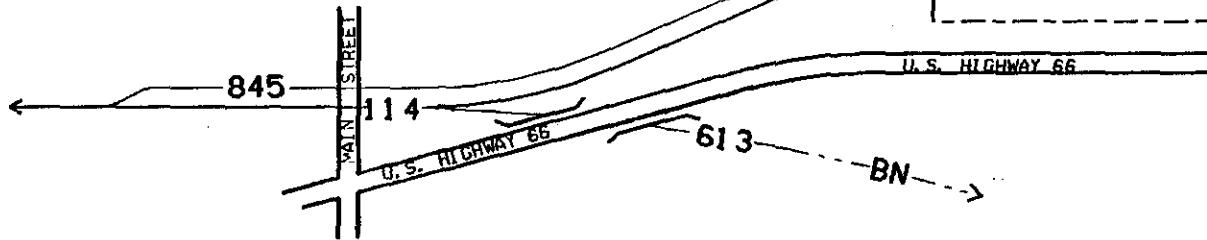
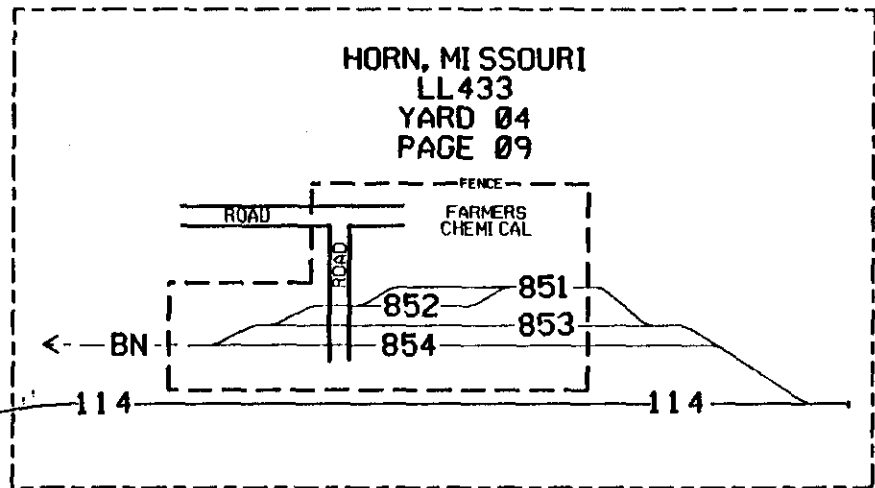

VAN BUREN DIVISION
 SERVICE UNIT 5
 YARD 01
 COFFEYVILLE OCC
COFFEYVILLE SUBDIVISION

COFFEYVILLE, KANSAS

R 136

130		EVANS MAIN
131		EVANS PASS
132		COX MAIN
133		COX PASS
134		BELT LINE
401		KDR SPUR (STORAGE)
403		SOUTH UNION ELECTRIC (STORAGE)
405		OLD MAIN (STORAGE)
407		STORAGE #2
520		ENGINE SPOT
521		CENTER DUMP (SAND CARS)
522		ENGINE DUMP
600	98	MKT/ATSF/UP WYE
601	98	UP RECEIVING
602	98	UP DELIVERY
620	98	ATSF/MKT CONNECTION
708		INDEPENDENT MILLS #5
709		INDEPENDENT MILLS #6
710		INDEPENDENT MILLS #4
711		INDEPENDENT MILLS #3
712		INDEPENDENT MILLS #2
713		INDEPENDENT MILLS #1
802		CARESIO BROTHERS
805		SOYBEAN #2 (FARMLAND)
806		SOYBEAN #1 (FARMLAND)
809		LPG #2 (FARMLAND)
810		LPG #1 (FARMLAND)
812		STORAGE #1 (CO-OP LEASE)
814		HANKS (FARMLAND LEASE)
815		HEAVY OIL #2 (FARMLAND)
816		HEAVY OIL #1 (FARMLAND)
818		COKE PIT (FARMLAND)
819-820		CATCRACKER #1-2 (FARMLAND)
825		BARRELL HOUSE (FARMLAND)
826-827		LUBE #1-2 (FARMLAND)
828		LUBE PUMPOUT (FARMLAND)
830-831		COAL PIT #1-2 (FARMLAND)

U. P. JUNCTION, OKLAHOMA

L 321

140 MAIN LINE

WANN, OKLAHOMA

RB183

140 MAIN LINE

840 99 TEAM TRACK

DEWEY, OKLAHOMA

RB193

140 MAIN LINE

845 P & M

BARTLESVILLE, OKLAHOMA

RB198

040 HILL TRACK/ATSF INTERCHANGE

041 RIP TRACK

042 BACK TRACK

140 SUTTON MAIN

141 SUTTON PASS

850 SAWMAX STUB (VACANT)

855-856 ACID TRACK #5-6

859 NORTH ALLEY (#4 TRACK)

860 THAW SHED

863 HIGH LINE

864 DECLINE

865 #15 TRACK

868 OLD METAL

870 CALC. UNLOAD/SCALE TRACK

880 STRAIGHT TRACK

882 NEW METAL

884 SHED

890 WYE TRACK

891 UNLOADING TRACK

892 PREMIUM LEAD/FERTILIZER TRACK

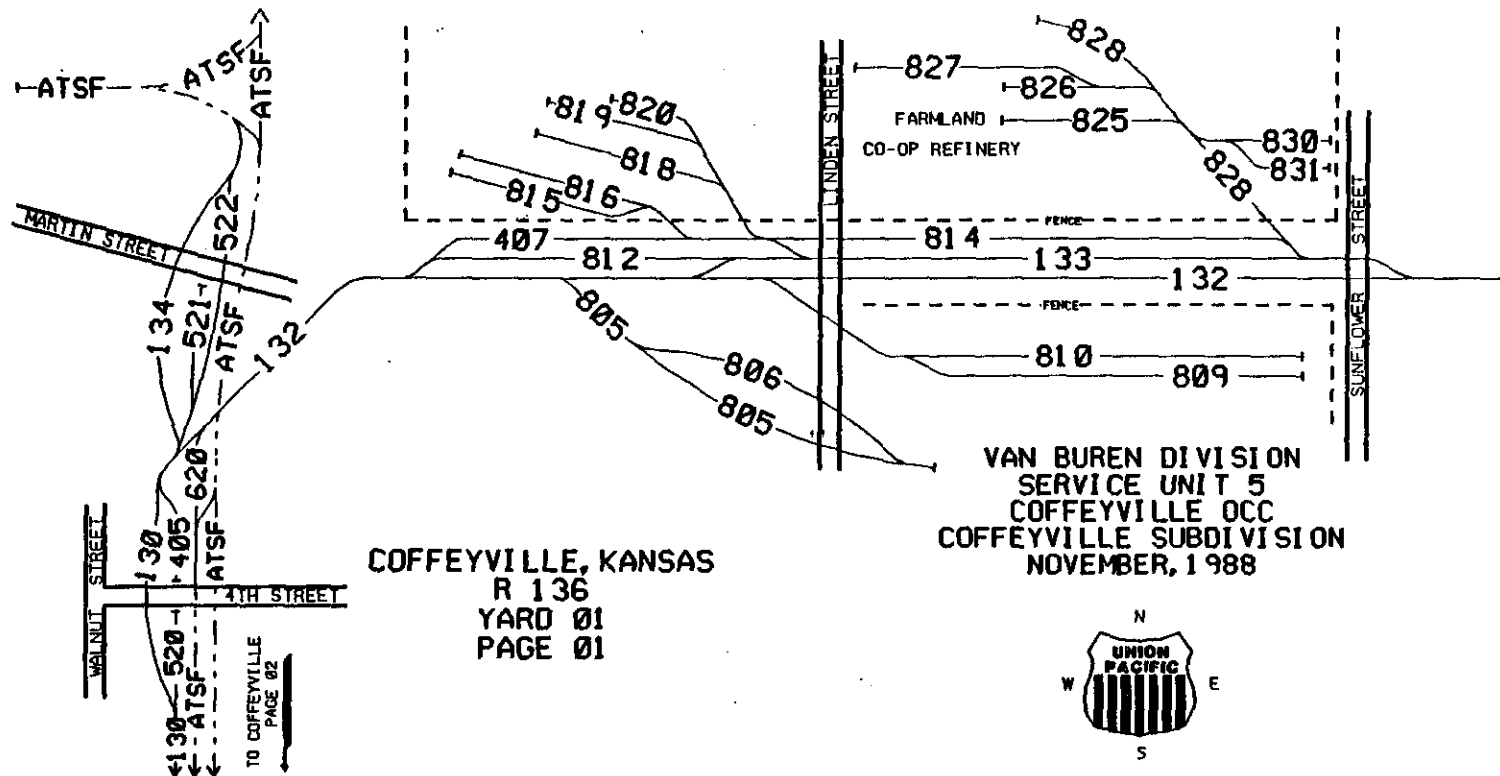

COFFEYVILLE, KANSAS
 R 136
 YARD 01
 PAGE 01

VAN BUREN DIVISION
 SERVICE UNIT 5
 COFFEYVILLE OCC
 COFFEYVILLE SUBDIVISION
 NOVEMBER, 1988



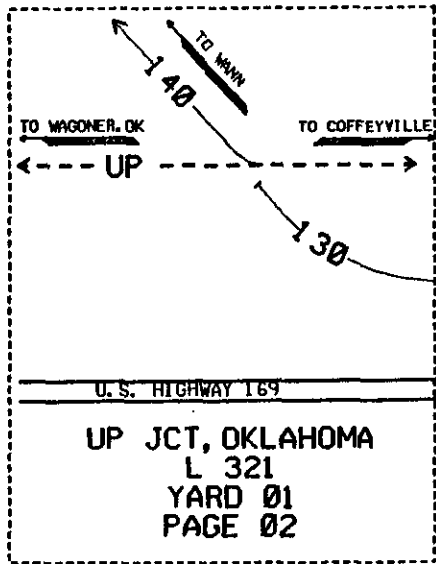

UP JCT, OKLAHOMA
L 321
YARD 01
PAGE 02

OKLAHOMA
KANSAS

COFFEYVILLE, KANSAS
R 136
YARD 01
PAGE 02

VAN BUREN DIVISION
SERVICE UNIT 5
COFFEYVILLE OCC
COFFEYVILLE SUBDIVISION
NOVEMBER, 1988

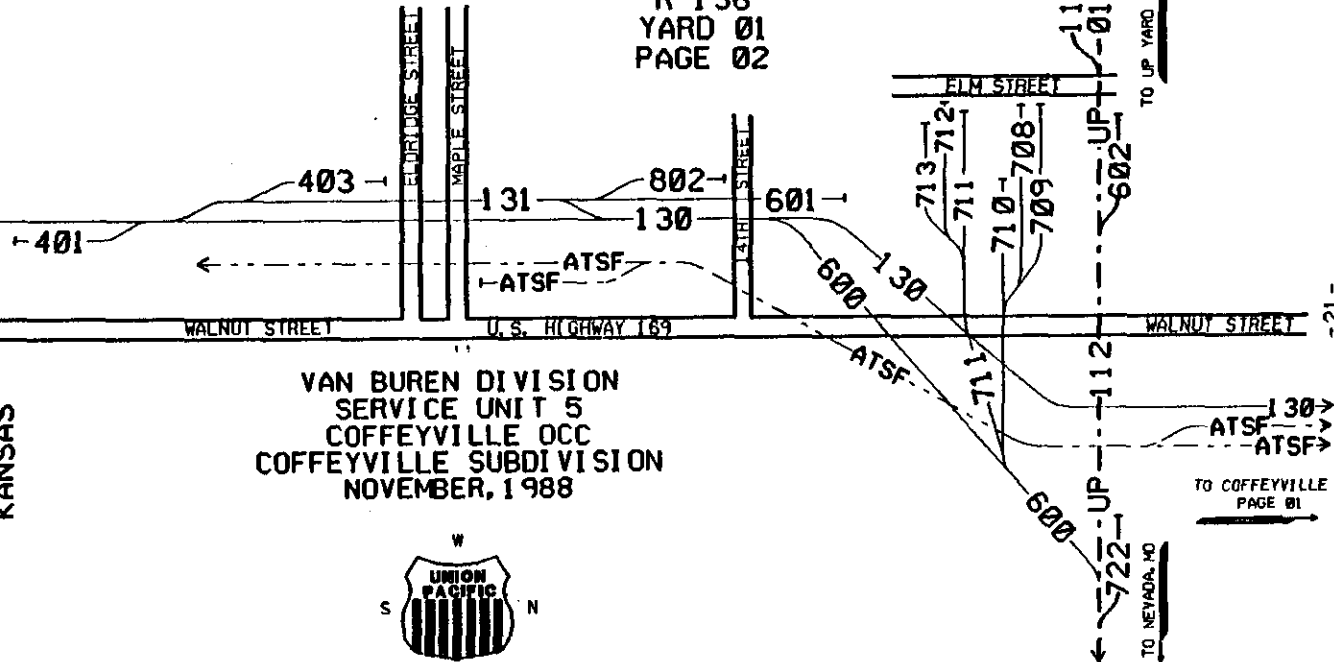

-21-

TEXOMA DIVISION
SERVICE UNIT 17
YARD 02
MUSKOGEE OCC
CHEROKEE SUBDIVISION
TULSA SUBDIVISION

MUSKOGEE, OKLAHOMA

MG002

053-054	YARD TRACKS *3-4
056-058	YARD TRACKS *6-8
060	YARD TRACK *10
061	SCALE
065	10 RAIL AC FR YD OFF
130	MAIN LINE
131	COOBY CREEK PASS
132	YARD TRACK *1
133	OLD ENG DUMP
525	JOY
526	CAB TRACK
527	MCGEE LEAD
611-612 99	UP CONNECTION
615 99	BN CONNECTION
900	FARMLAND EAST
901	FARMLAND COOP
903	COF DISTRIBUTING
906	QUALITY LIQUID FEED/MKT STOREROOM
908	VACANT (BEER HOUSE)
910	GRIFFIN GROCERY LEAD
911-913	GRIFFIN GROCERY *1-3
918	ROYAL CASKET/KETCHUM LUMBER
918	NELSON FURNITURE
920	CORNING WAREHOUSE (VACANT)
925	COLE GRAIN
926	WP MILL
930	BUSH CANNED FOODS
935	OKLAHOMA BRICK (MK509)

TULSA SUBDIVISION

WYBARK, OKLAHOMA

MM324

147	NORTH LEG OF WYE
148	SOUTH LEG OF WYE
149	WYBARK PASS
170	MAIN LINE

ANCHOR, OKLAHOMA

MM320

170	MAIN LINE
810	ANCHOR COAL

PORTER, OKLAHOMA

MM313

170	MAIN LINE
811 99	COWETA SAND & GRAVEL/TEAM TRACK

PATCH, OKLAHOMA

MM312

170	MAIN LINE
812	BILLS COAL

COWETA, OKLAHOMA

MM304

170	MAIN LINE
813	CAN PAC
814	CO-OP FERTILIZER

ONETA, OKLAHOMA

MM297

170	MAIN LINE
815	UNION BUILD

TEXOMA DIVISION
SERVICE UNIT 17
YARD 02
MUSKOGEE OCC
TULSA SUBDIVISION

BROKEN ARROW, OKLAHOMA

MM292

170		MAIN LINE
405-406		PASS #1-2
411-413		FORD PASS #1-3
816		CONTINENTAL INDUSTRIES
817	99	FARMERS COOP & TEAM
820		THERMO DYNAMICS
821		SUTHERLAND LUMBER
822		FREEMAN PRODUCTS
823		CEDAR CREEK LUMBER
824		BACKER PACKERS LEAD
825		BACKER PACKERS
941		FORD GLASS STORAGE #1
942		FORD GLASS STORAGE #2
943		FORD GLASS STORAGE #3
944		FORD GLASS STORAGE #4
945		FORD GLASS STORAGE #5

TULSA, OKLAHOMA

MV153

071-073		PASS #1-3
170		TULSA MAIN LINE
175		INDUSTRIAL LEAD
177		NORTH LEG OF WYE
178		SOUTH LEG OF WYE
180		DOWNTOWN PASS
415, 418		HOLD TRACKS
606	98	BN INTERCHANGE
833		LOWE'S
834		EDWARD HINES (VACANT)
835		PUBLIC SERVICE
836-839		AUTO CONVOY
840		ABC ROOFING LEAD
841		ABC ROOFING
842-843		ARMIA PLASTICS
844		SONOCO
845		MONFORT FOODS
847		DELTA SOLVENT/SEARS
848		BEST SHOT WATER BEDS
849		ROUNDS & PORTER
850-851	96	RAMPS PIG #1-2
852		MORE INSULATION & SUPPLY
853		M & M LUMBER
854		ARMIA PLASTICS LEASE
855		HUGHES LUMBER
856		BYRON JACKSON
858		VACANT
859-861		G. C. BROACH
862		VACANT
863-864		KAISER
865	99	TEAM & DOCK
866		HODGES MOVING
867-871		SAFEWAY GROCERY (VACANT)
872		COLOR GRAPHICS
873		SEQUOIA SUPPLY
874		TAMKO/KLOCKNU-MOELLER
875		VACANT
877		FADLERS
878		ENVIROCON INTERNATIONAL CORP
879		HUTTIG SASH & DOOR
881		WESTERN PAPER
884		SPACE CENTER
885		HOPE LUMBER
886		SPACE CENTER
888	99	TEAM & COMMERCIAL LUMBER
891-892		VACANT

TO MUSKOGEE VIA UP
PAGE B2

MUSKOGEE, OKLAHOMA
MG002
YARD 02
PAGE 01

TEXOMA DIVISION
SERVICE UNIT 17
MUSKOGEE OCC
CHEROKEE SUBDIVISION
NOVEMBER, 1988

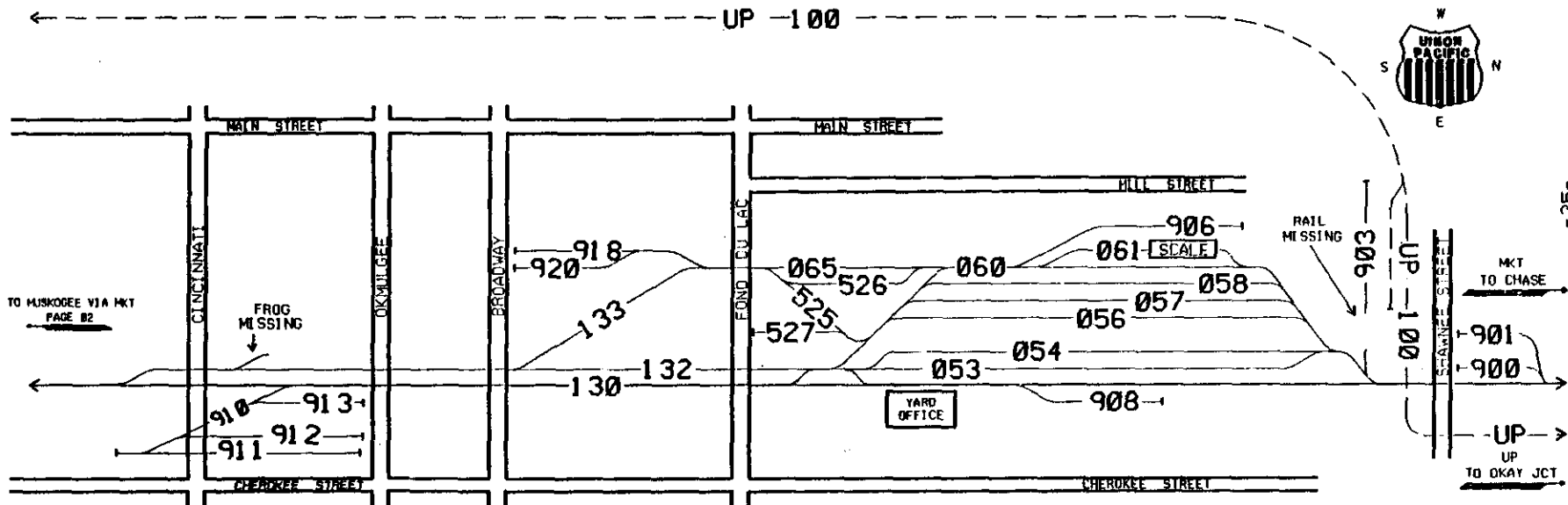

TO MUSKOGEE VIA MKT
PAGE B2

TO HENRYETTA

UP -100

TO TULSA

UP-008

111

007

006

MUSKOGEE, OKLAHOMA
MG002
YARD 01
PAGE 02

TO MCALESTER

1-935

130

930

130

925

926

131

612

611

615

UP-610

BN

BN

TO UP YARD

UP

TO MUSKOGEE
PAGE 01

-26-

TEXOMA DIVISION
SERVICE UNIT 17
MUSKOGEE OCC
CHEROKEE SUBDIVISION
NOVEMBER, 1988



CHEROKEE

SOUTHWEST BOULEVARD

COWETA, OKLAHOMA
MM304
YARD 02
PAGE 03

PATCH, OKLAHOMA
MM312
YARD 02
PAGE 03

PORTER, OKLAHOMA
MM313
YARD 02
PAGE 03

ANCHOR, OKLAHOMA
MM320
YARD 02
PAGE 03

WYBARK, OKLAHOMA
MM324
YARD 02
PAGE 03

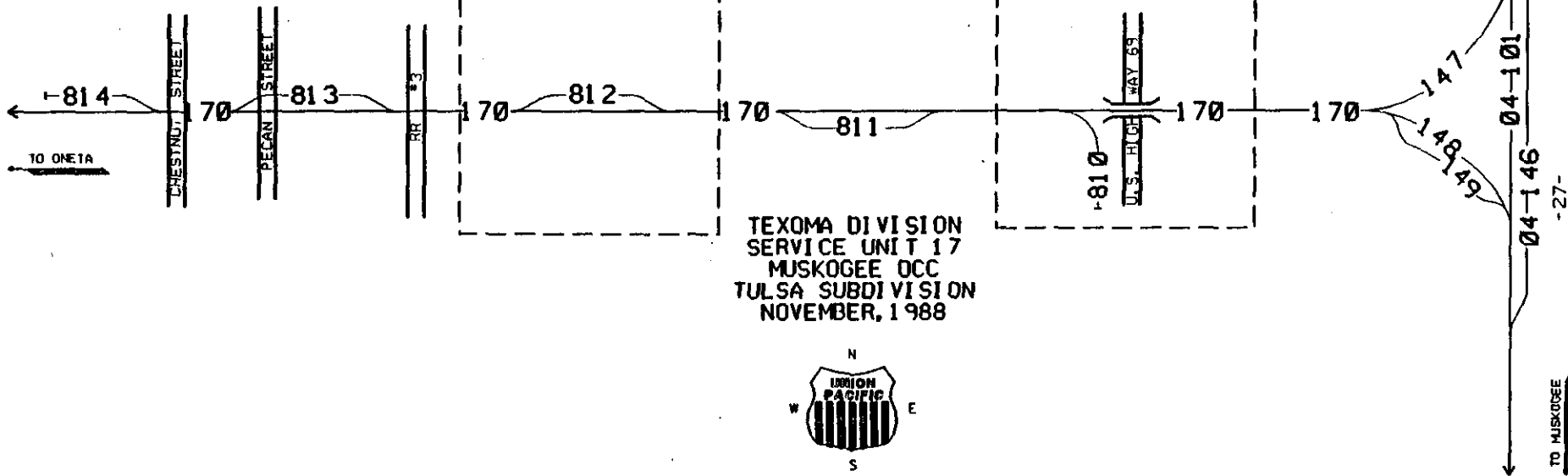

TEXOMA DIVISION
 SERVICE UNIT 17
 MUSKOGEE OCC
 TULSA SUBDIVISION
 NOVEMBER, 1988
 REVISED: JANUARY, 1989

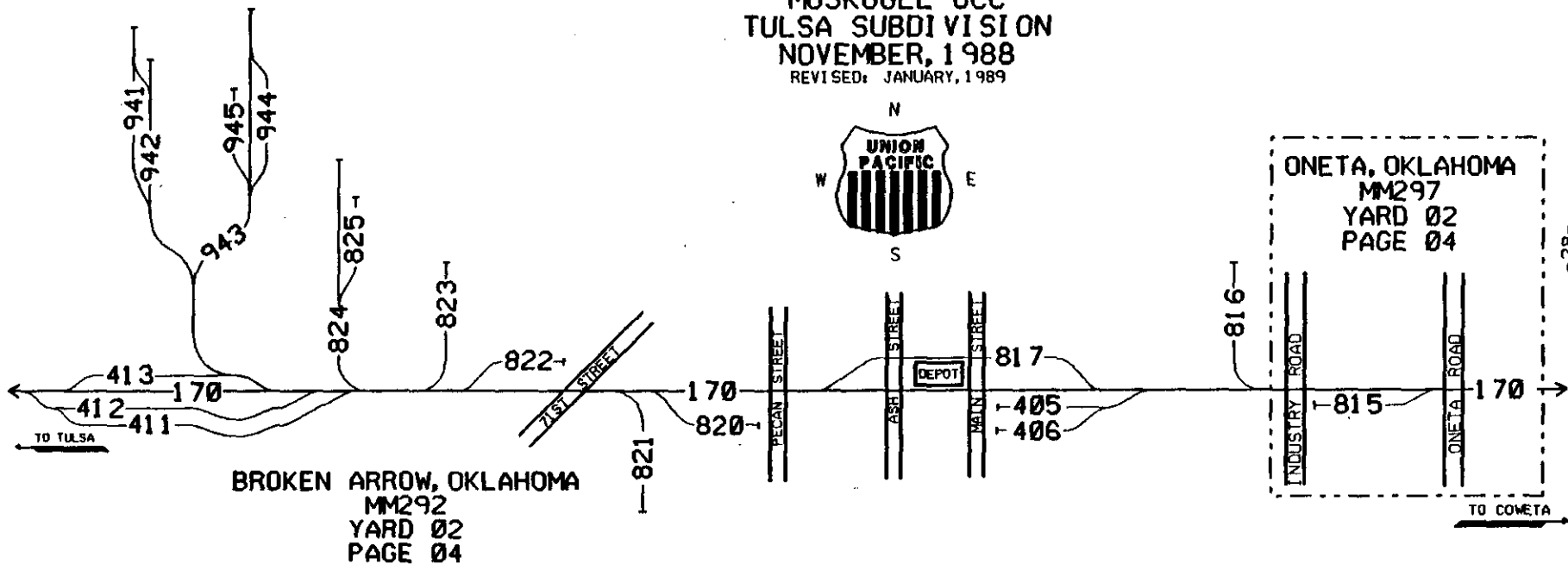

BROKEN ARROW, OKLAHOMA
 MM292
 YARD 02
 PAGE 04

TULSA, OKLAHOMA
MV153
YARD 02
PAGE 05

TEXOMA DIVISION
SERVICE UNIT 17
MUSKOGEE OCC
TULSA SUBDIVISION
NOVEMBER, 1988

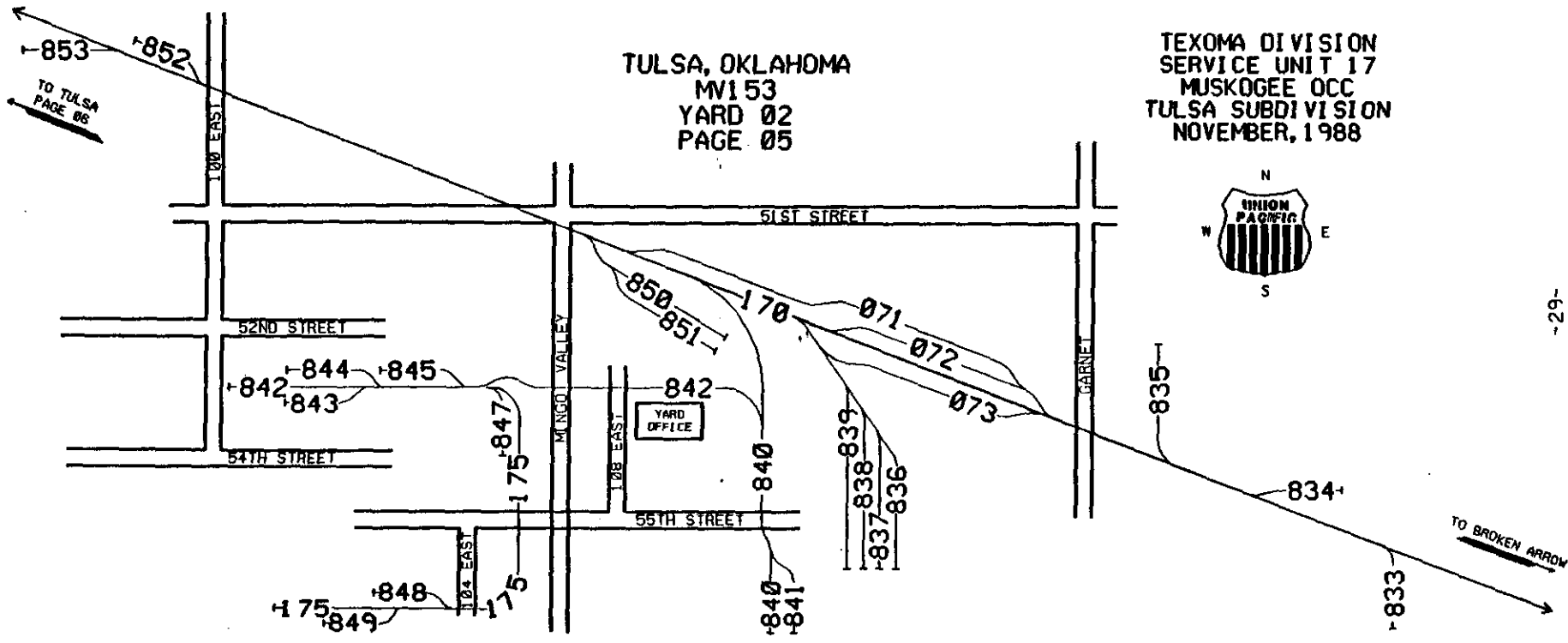

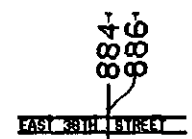
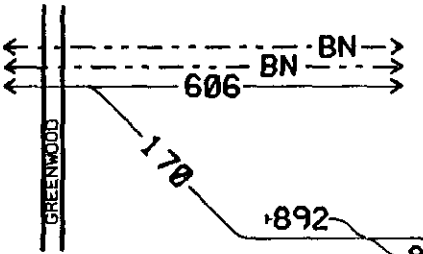

TULSA, OKLAHOMA
 MVI 53
 YARD 02
 PAGE 06

TEXOMA DIVISION
 SERVICE UNIT 17
 MUSKOGEE OCC
 TULSA SUBDIVISION
 NOVEMBER, 1988

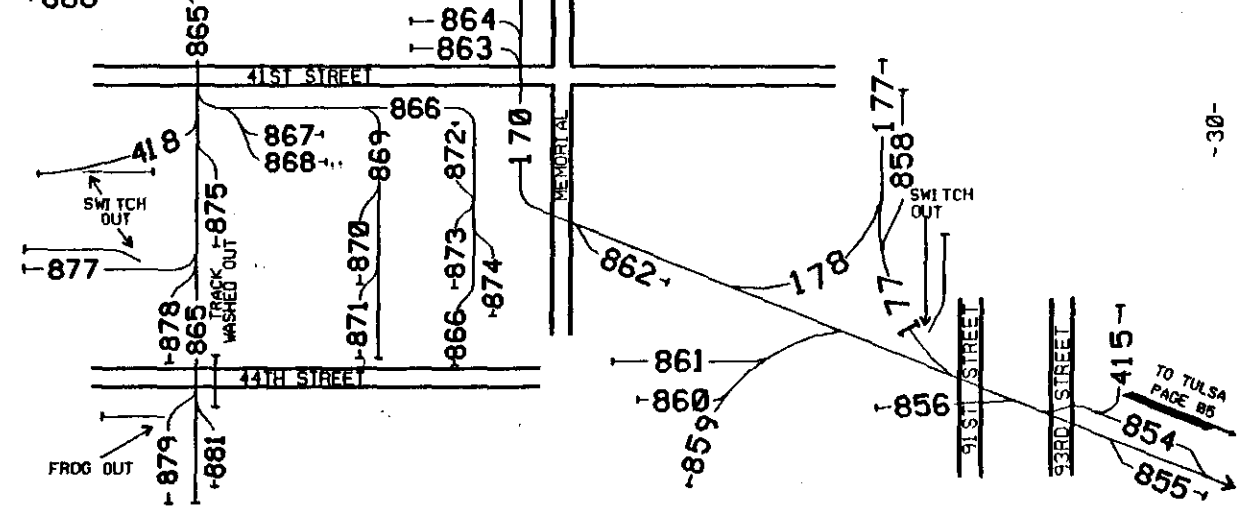

TEXOMA DIVISION
SERVICE UNIT 17
YARD 05
MUSKOGEE OCC
CHOCTAW SUBDIVISION

CHECOTAH, OKLAHOMA **MK525**

101		MAIN LINE
105		CHECOTAH PASS
701	99	WEST TEAM
702	99	EAST TEAM/T. H. ROGERS LUMBER
703		ALUMINUM SERVICE CORP.

EUFAULA, OKLAHOMA **MK538**

101		MAIN LINE
710	99	TEAM TRACK/EUFAULA FARM & FEED
710		NELSON FEED & SEED

CANADIAN, OKLAHOMA **MK547**

101		MAIN LINE
108		CANADIAN PASS
401		POCKET TRACK

MCALESTER, OKLAHOMA **MK566**

005-008		*5-8 RAIL
101		MAIN LINE
109		NORTH PASS
110		SOUTH PASS
112		NORTH LEG WYE
113		SOUTH LEG WYE
114		TAIL TRACK
116		KREBS BRANCH
117		INDUSTRY LEAD
120		WEST LEAD
122		NORTH LEG OKT WYE
123		SOUTH LEG OKT WYE
130		OKT MAIN LINE
131		OKT PASS
132		NEW INDUSTRY PARK LEAD
208		NORTH 8 RAIL
218		SCALE
220		NORTH LEAD
403		CAB TRACK
404		DUMP TRACK
405		RIP #1
410		HAMMER TRACK
411		HOLE
412		SET BACK TRACK
413		SOUTH TRACK
501		ENG DUMP/SAND
503		BAD ORDER TRACK
713	99	TEAM TRACK
714		PIGGY BACK
716		COAL YARD/DUNCAN PEANUTS
718		COMMODITY WAREHOUSE
719		BIG V FEED
720	99	TERRA/TEAM
722		MCALESTER IRON & METAL
723		MCALESTER OIL MILL
724	99	TEAM TRACK
726-727		EDISON PLASTIC
730		WESTERN

INCLUDED IN MCALESTER SWITCHING LIMITS

NAVY, OKLAHOMA **MK573**

101		MAIN LINE
135		NAVY PASS
735		NORTH LEG WYE
736		SET OUT TRACK
737		BATCHER TRACK
738		SOUTH LEG WYE

TEXOMA DIVISION
SERVICE UNIT 17
MUSKOGEE OCC
CHOCTAW SUBDIVISION
NOVEMBER, 1988



CHECOTAH, OKLAHOMA
MK525
YARD 05
PAGE 01

EUFAULA, OKLAHOMA
MK538
YARD 05
PAGE 01

CANADIAN, OKLAHOMA
MK547
YARD 05
PAGE 01

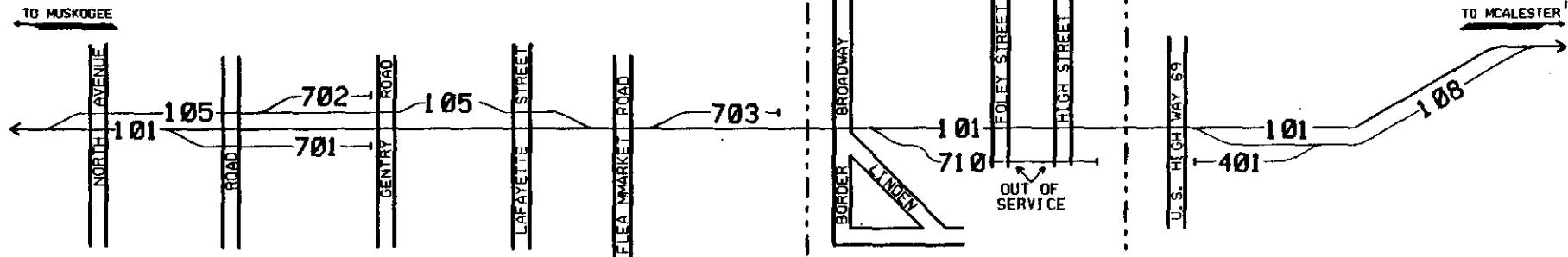

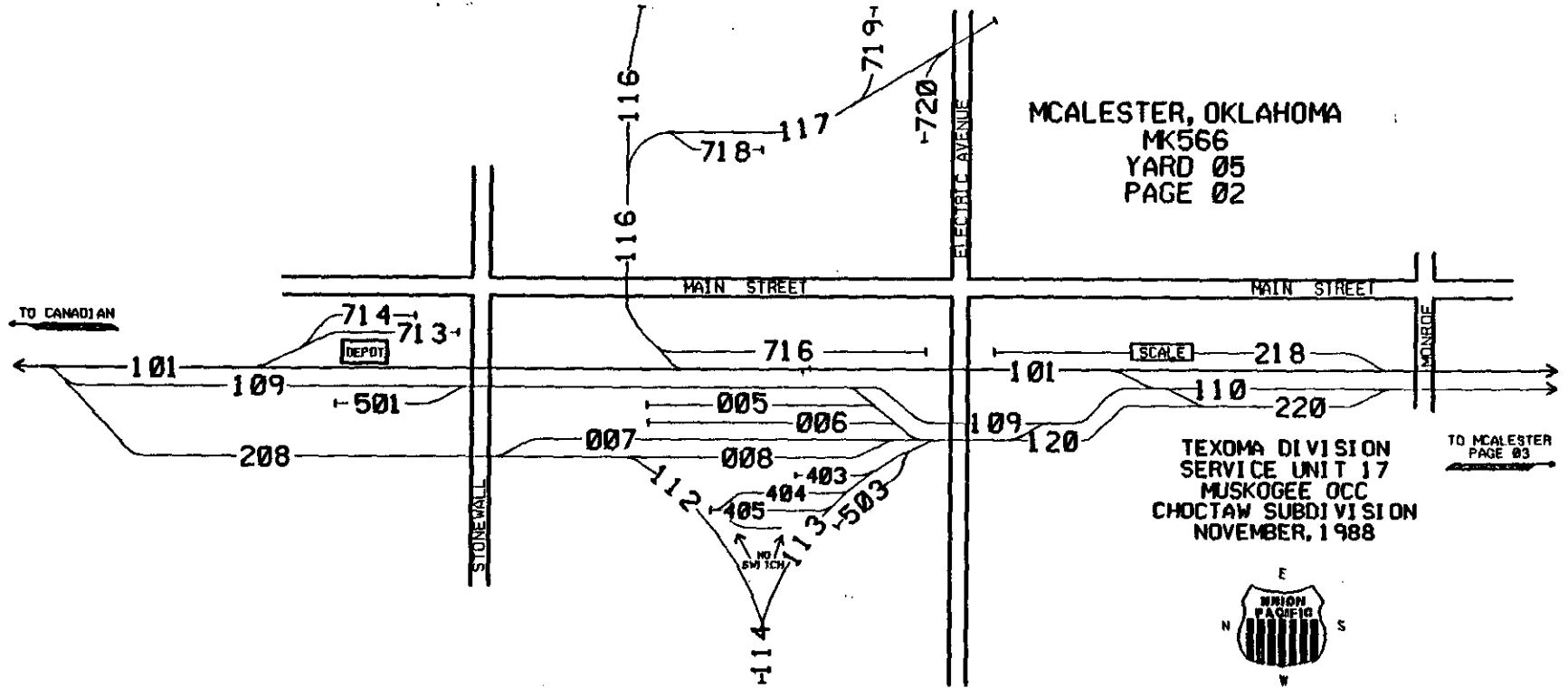

MCALESTER, OKLAHOMA
 MK566
 YARD 05
 PAGE 02

TEXOMA DIVISION
 SERVICE UNIT 17
 MUSKOGEE OCC
 CHOCTAW SUBDIVISION
 NOVEMBER, 1988

TO MCALESTER
 PAGE 03



