



TULSA TERMINAL
INDUSTRY SCHEMATICS

OPERATIONS PLANNING
DEPARTMENT

March 1978

TULSA TERMINAL

ZONE 1

GREATER TULSA INDUSTRIAL DISTRICT
West of Cherokee Yard

ZONE - 1 GREATER TULSA INDUSTRIAL DISTRICT - WEST OF CHEROKEE YARD

<u>SPOT No.</u>	<u>INDUSTRY NAME</u>
103	Open
115	Thirty-Third Street team track
140	Affiliated Food Stores Incorporated
142	Open
143	Dupont De Nemours & Company, E.I.
145	Norris Division Dover Corporation - Sucker rod plant
150	Utility Steel Company
151	Tulsa Poly Film Incorporated
160	General Steel Fabricating Incorporated
163	Grace, W. R., & Company
164	Holloway Company, The
165	Chemco Products Incorporated
167	D-A Lubricant Company, Incorporated
169	Kress, S. H., & Company
170	Bradford Company
188	Tulsa Forge Incorporated
190	Unit Rig & Equipment Company

TULSA TERMINAL

ZONE 2

SECTION 1

CHEROKEE YARD AREA

ZONE 2 - SECTION 1 - CHEROKEE YARD AREA

<u>SPOT No.</u>	<u>INDUSTRY NAME</u>
220	Frisco Maintenance of Way
233	Rogers Galvanizing Company No. 2
275	Grant Supply Company
277	Flint Steel Corporation
279	Sun Chemical Corporation, Division General Printing Ink
280	Frisco wrecker track
283	Frisco locomotive ready tracks
284	Frisco panel rail tracks
285	Frisco mechanical area
287	Frisco diesel lub oil (L) and sand (S) unloading
289	Frisco diesel fuel oil racks
292	Frisco ice spur
293	Frisco west caboose track
295	Frisco scale track
297	Frisco east caboose track
298	Frisco rip tracks
299	Frisco TOFC and automobile ramp

TULSA TERMINAL ZONE 2-SECTION 1

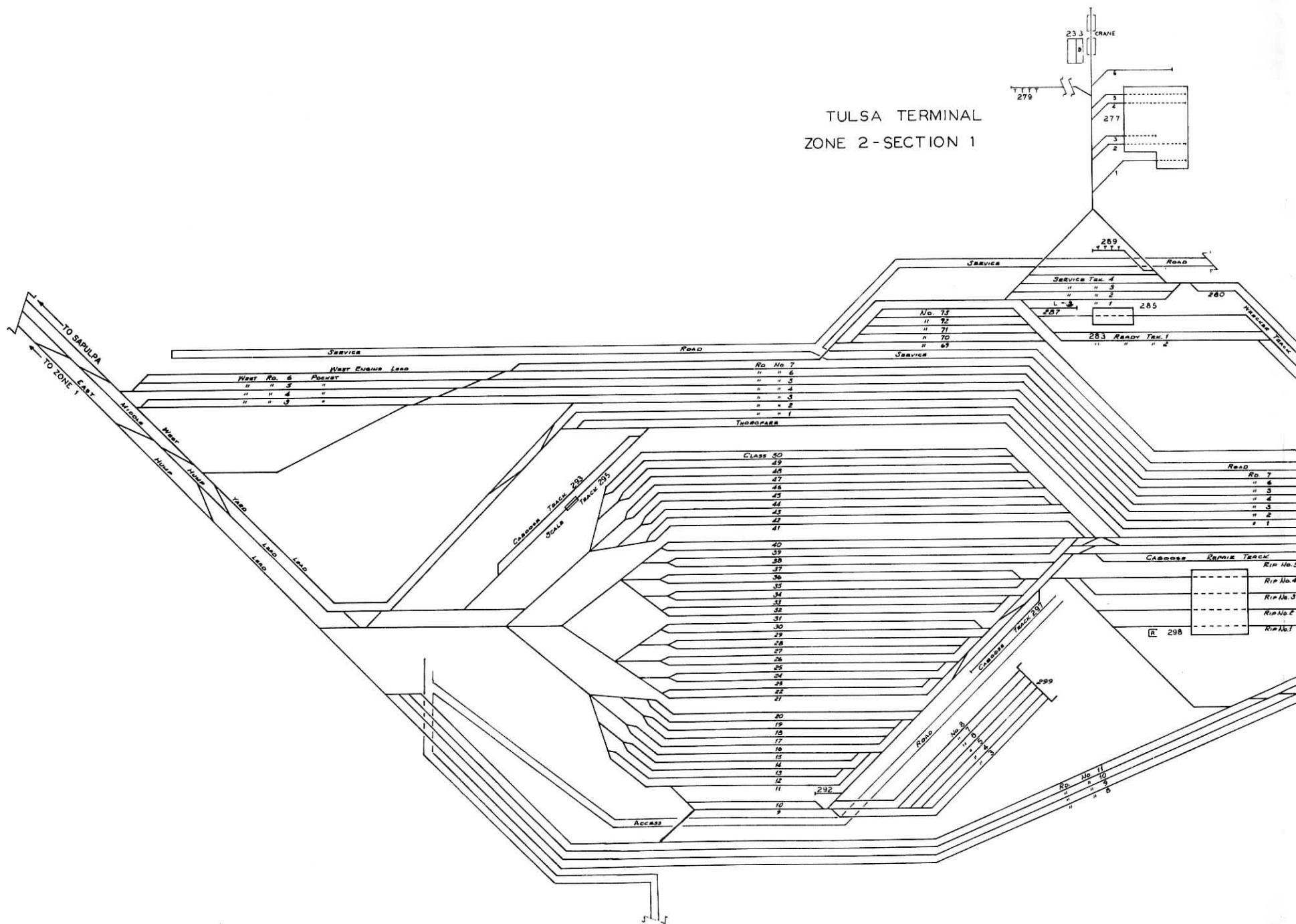

TO SAPULPA
TO ZONE EAST

West No. 6	POCKET
" " 3	"
" " 4	"
" " 3	"

Rd No 7
" " 6
" " 5
" " 4
" " 3
" " 2
" " 1

CLASS
50
49
48
47
46
45
44
43
42
41
40
39
38
37
36
35
34
33
32
31
30
29
28
27
26
25
24
23
22
21
20
19
18
17
16
15
14
13
12
11
10
9

Rd No 11
" " 10
" " 9
" " 8

CARROSS	REPAIR TRACK	RIP No.
		RIP No. 5
		RIP No. 4
		RIP No. 3
		RIP No. 2
		RIP No. 1

233 CRANE

279

277

269

No. 73

" " 72

" " 71

" " 70

" " 69

287

285

280

283 Ready Trk. 1

" " 2

Rd 7

" " 6

" " 5

" " 4

" " 3

" " 2

" " 1

R 298

Rd No 8

" " 7

" " 6

" " 5

" " 4

" " 3

" " 2

" " 1

292

Access

PPP

TULSA TERMINAL
ZONE 2 - SECTION 1

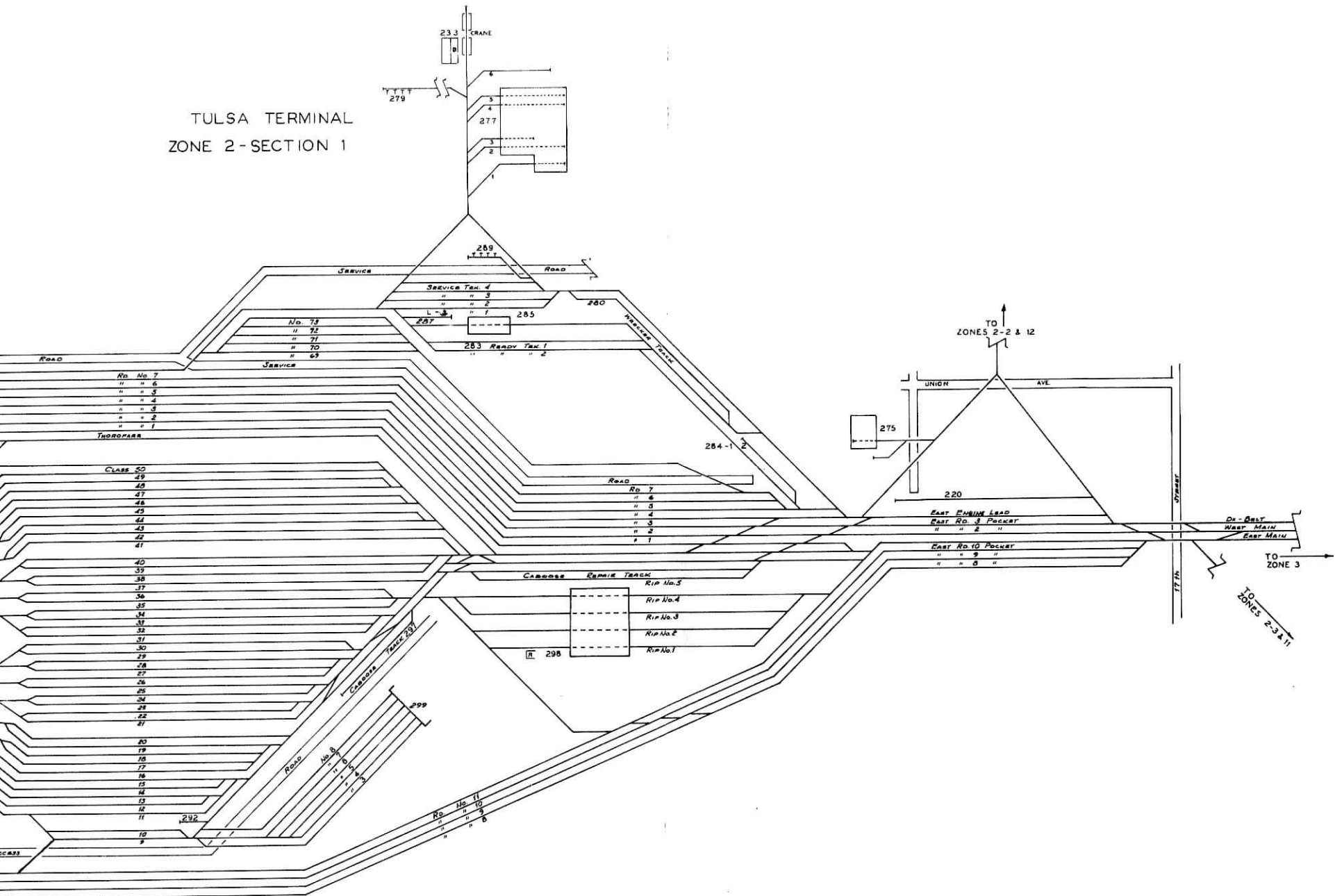

- Rd. No. 7
" " 6
" " 5
" " 4
" " 3
" " 2
" " 1
- THORPARK
- CLASS 50
- 49
48
47
46
45
44
43
42
41
- 40
39
38
37
36
35
34
33
32
31
30
29
28
27
26
25
24
23
22
21
- 20
19
18
17
16
15
14
13
12
11
- 9

- Carbide Repair Track
- RIP No. 5
RIP No. 4
RIP No. 3
RIP No. 2
RIP No. 1
- 298

TO ZONES 2-3 & 11

TULSA TERMINAL

ZONE 2

SECTION 2

CHEROKEE YARD to ARKANSAS RIVER

North of Main Line

ZONE 2 - SECTION 2 - CHEROKEE YARD TO ARKANSAS RIVER - NORTH OF MAIN LINE

<u>SPOT No.</u>	<u>INDUSTRY NAME</u>
227	Pan Lead
230	Riverside Industries Incorporated
231	Grant Supply Company - Pipe yard
232	Ozark-Mahoning Company
234	Tulsa Warehousing Company
235	Rogers Galvanizing Company No.1
236	Ashland Chemical Company
237	Drum Service Incorporated
238	Esex Incorporated
239A	A.V.W. Storage track No.1
239B	A.V.W. Storage track No.2
239C	A.V.W. Storage track No.3
241	A.V.W. Scale track
244	Builders Steel Company, Incorporated
247	Bosco Services
249	Ozark storage track
254	Mohawk Rock & Sand Company
256	Arkansas River Sand Company
278	Flintco

TULSA TERMINAL ZONE 2 SECTION 2

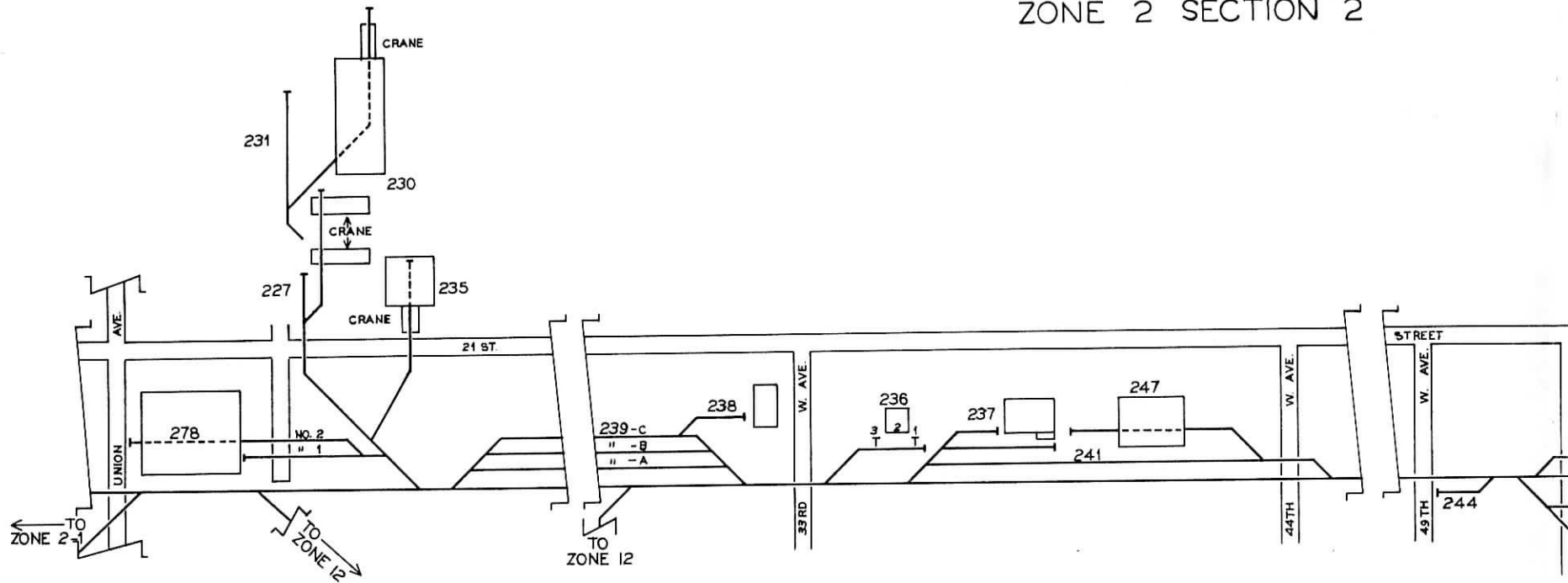

TULSA TERMINAL
ZONE 2 SECTION 2

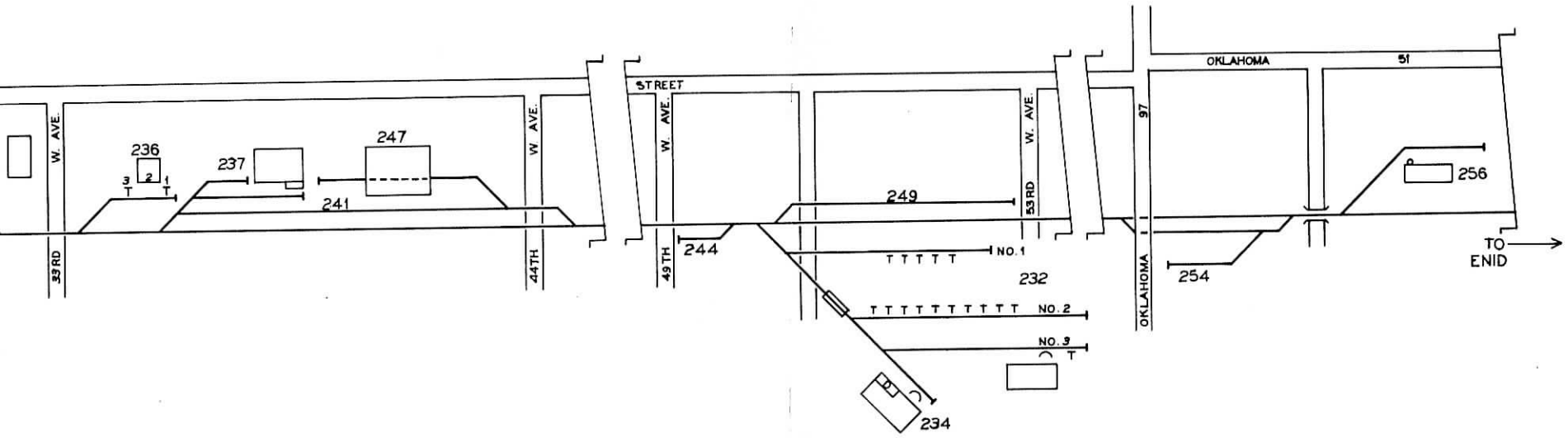

TULSA TERMINAL

ZONE 2 - SECTION 3

AND

ZONE 11

CHEROKEE YARD to ARKANSAS RIVER

South of Main Line

ZONE 2 - SECTION 3 AND ZONE 11 - CHEROKEE YARD TO ARKANSAS RIVER - SOUTH OF MAIN LINE

ZONE 2 - SECTION 3

<u>SPOT No.</u>	<u>INDUSTRY NAME</u>
202	Ethyl Corporation
206	Interchange tracks - Missouri Pacific Railroad
207	Texas runaround track
221	Open
224	Tulsa, City of - Water Department

ZONE 11

1123	Texaco Incorporated
------	---------------------

TULSA TERMINAL ZONES 2 SECTION 3 & 11

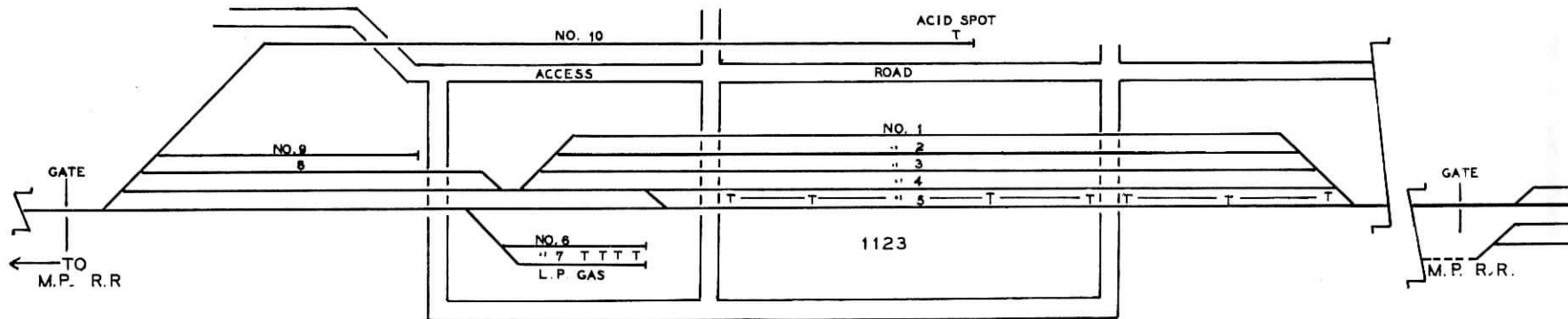

TULSA TERMINAL ZONES 2 SECTION 3 & 11

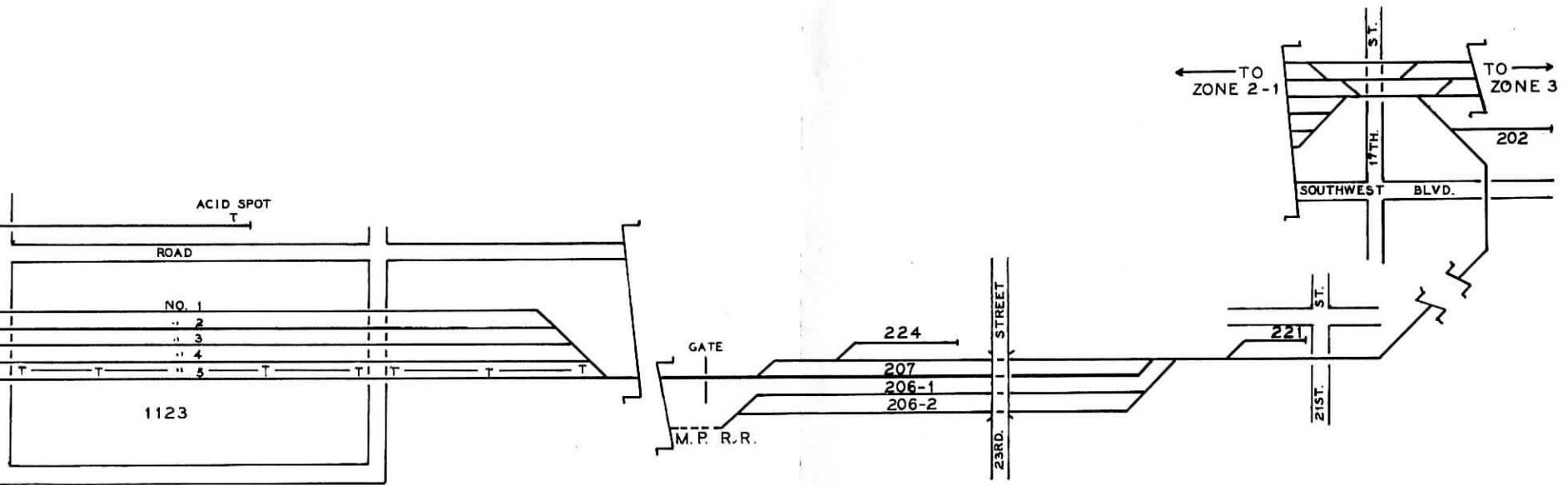

TULSA TERMINAL

ZONE 3

ARKANSAS RIVER to INTERLOCKING

ZONE 3 - ARKANSAS RIVER TO INTERLOCKING

<u>SPOT No.</u>	<u>INDUSTRY NAME</u>
301	Interchange delivery track to Sand Springs Railway
302	Interchange receiving track from Sand Springs Railway
303	Open
305	Open
308	Norris Division Dover Corporation
309	Public Service Company of Oklahoma - Pole Yard
311	Thermal Systems Incorporated
312	Thermal, J. F., Company
313	Oklahoma Lighting & Electrical Distributors
314	Cheyenne team track
316	Mid West Paper Products
318	Kerr, C. B., Warehouse & Storage
328	Nichols Transfer & Storage Company
339	Newspaper Printing Corporation
340	Tamco Roofing Company
341	Frisco Depot track No. 6
343	Frisco Depot track No. 5
345	Frisco Depot track No. 4
358	Frisco Freight House stub track No. 1
359	Elgin team track - South of main lines
361	Frisco Freight House
363	Universal Carloading & Distributing Company
364	Beene Paper Company
368	Gear, Lester Warehouse
370	American Transfer & Storage Company
371	Interchange delivery track to M. K. T. Railroad
372	Elgin team track - North of main lines
385	Tulsa Shippers Association, Incorporated
387	Adams Enterprise
389	Mill Track

TULSA TERMINAL ZONE - 3

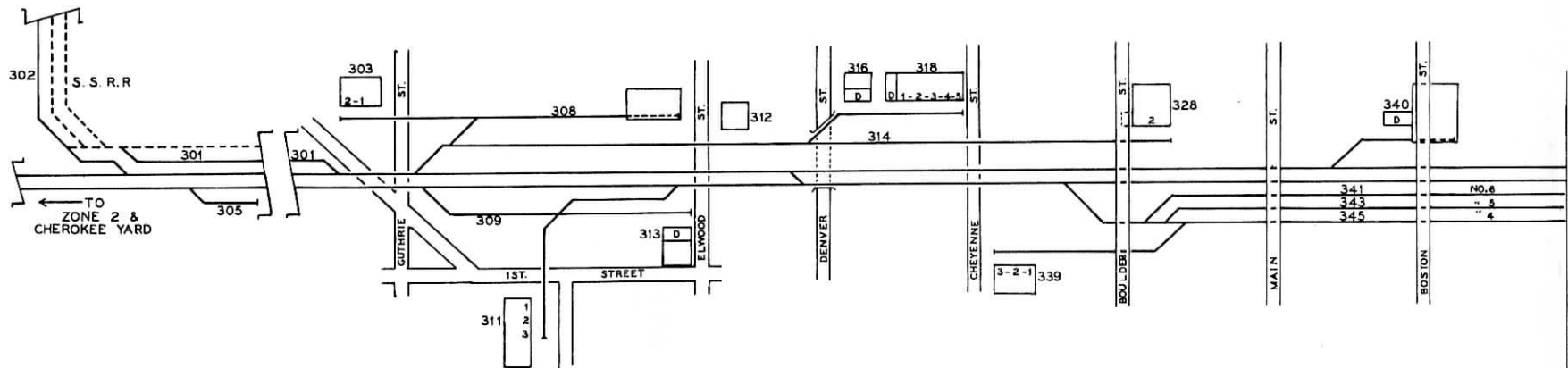

TULSA TERMINAL
ZONE - 3

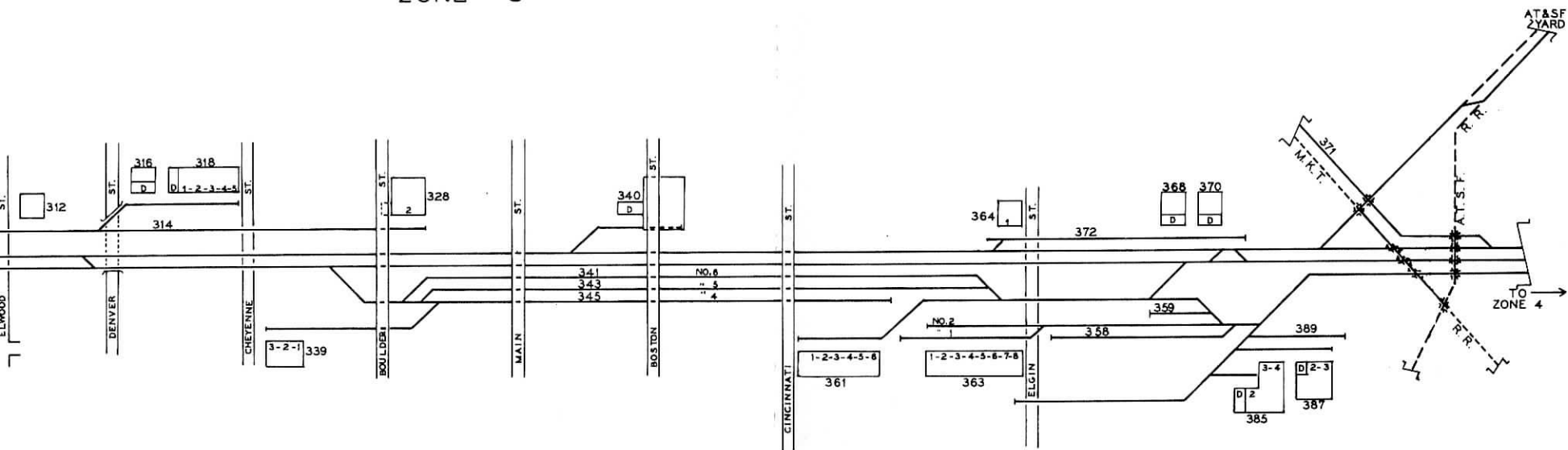

TULSA TERMINAL

ZONE 4

INTERLOCKING to EAST PINE STREET

ZONE 4 - INTERLOCKING TO PINE STREET

<u>SPOT No.</u>	<u>INDUSTRY NAME</u>	<u>SPOT No.</u>	<u>INDUSTRY NAME</u>
401	Trinnity Steel Company, Incorporated - Track No.3	462	Springdale Farms Incorporated
413	Old Village Lumber Company	463	Gate City Steel Company - West end of plant
415	Center-Line Incorporated	464	Belger Cartage Service Incorporated
417	Maloney-Crowford Tank Corporation	466	Bankoff Pipe & Supply Incorporated
419	Independent Material Company	467	Open
422	Frisco Maintenance of Way	469	Gate City Steel Company - East end of plant
423	Maloney-Crowford Tank Corporation	470	Crose International Incorporated
425	Storage No.1 - Madison Avenue	471	Linde Division of Union Carbide Corporation
426	Trenton Street team track	473	Broomtown Industries
427	Storage No.2 - Madison Avenue	474	Crosby Group, The
428	Open	475	Universal Metal Fabricators Incorporated
431	Walters Produce	476	Americal Junk Company
434	Arco Warehouse Corporation	477	Pennant Petroleum Company
436	Slage Manufacturing Corporation	478	Central Energy Products Incorporated
439	Tulsa Fruit Company	479	Ozark Water Company
440	Adams Box Company	480	Love Company, Incorporated
442	Borg Compressed Steel Company	481	United Insulation Company
445	Tulsa Produce Company	482	Yuba Heat Transfer - Air Cooled Products
447	Moley Produce Company	483	Standard Industries Incorporated
450	Whisco Steel Fabricators	484	Public Supply Company
451	Trinnity Steel Company, Incorporated - West end	490	Acme Brick Company
453	Trinnity Steel Company, Incorporated - East end	491	Starr Weld-Ell Service
455	Insta-Box & Supply Company, Incorporated	495	United Insulation Company
457	Utica spur track	499	Forest Builders Supply Exteriors Incorporated

TULSA TERMINAL
ZONE -4

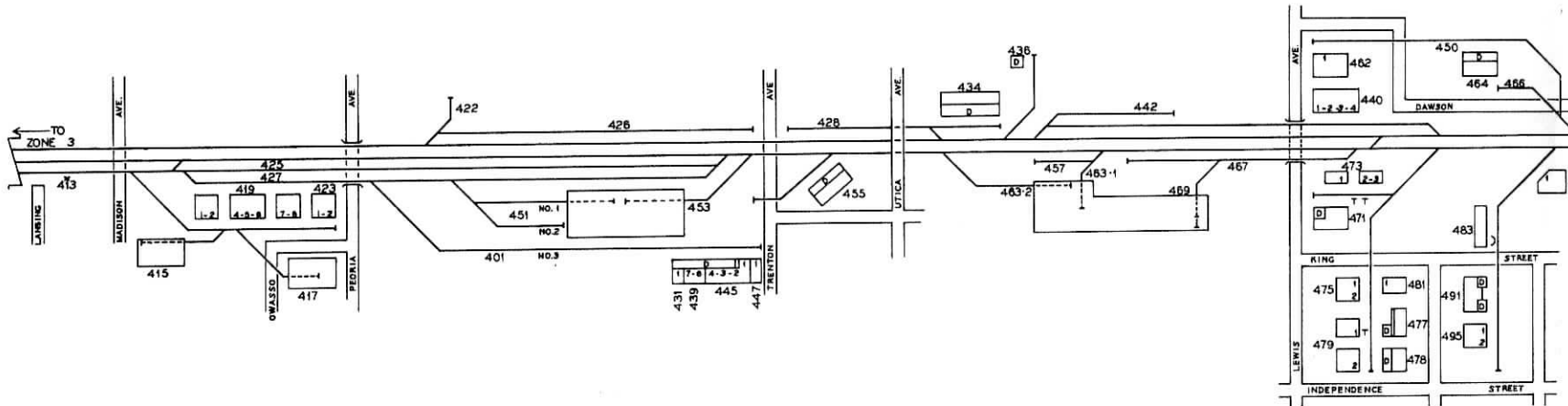

TULSA TERMINAL
ZONE -4

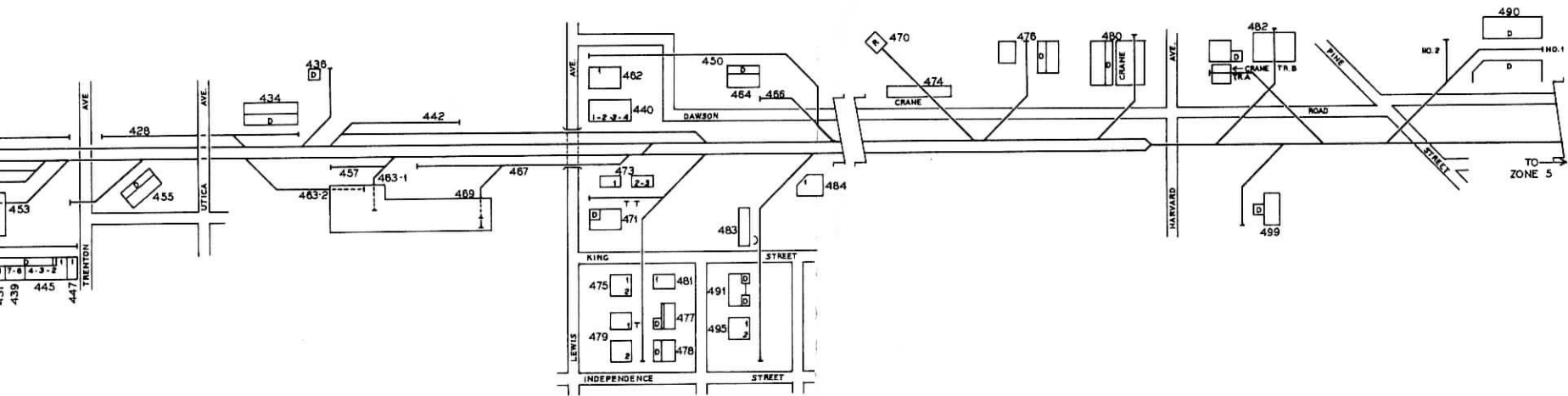

TULSA TERMINAL

ZONE 5

EAST PINE STREET to NORTH MINGO ROAD

ZONE 5 - PINE STREET TO MINGO ROAD

<u>SPOT No.</u>	<u>INDUSTRY NAME</u>
500	Sanders Feed Mills
501	Dawson Pass (Switch removed at west end)
503	Dawson runaround track
505	Dawson team track
509	Industrial lead track
511	Jarboe Lales Company
512	Maxwell Supply of Tulsa
513	All-States Insulation Corporation
515	Metro-Port Warehouse Corporation
519	Metro-Port Warehouse Corporation Annex
521	Brandt Equipment & Supply Company, Incorporated
523	Metal Goods Corporation
525	Open
527	Jorgensen, Earl M., Company
529	Newmans Incorporated
532	McMichael Concrete Company
533	Bomber Pass (Switch removed at east end)
540	Douglas Aircraft Company, Incorporated
542	North American Rockwell
550	Hale-Halsell Company
551	Lawhon, John F., Furniture Warehouse & Showroom
553	Open
570A	Metro-Port Warehouse Corporation No.3
570B	United Plate Glass Company
571	Beer Distributors Incorporated
573	Whittaker Metals Division of Whittaker Corporation
575	Stationers Distributing Company
580	Kilsby Tube Supply Company
581	Oklahoma Tire & Supply Company (OTASCO)
582	Fig M Warehouse
583	Midvale Mining & Manufacturing Company
584	Ecodyne Corporation, Cooling Products Division

TULSA TERMINAL
ZONE -5

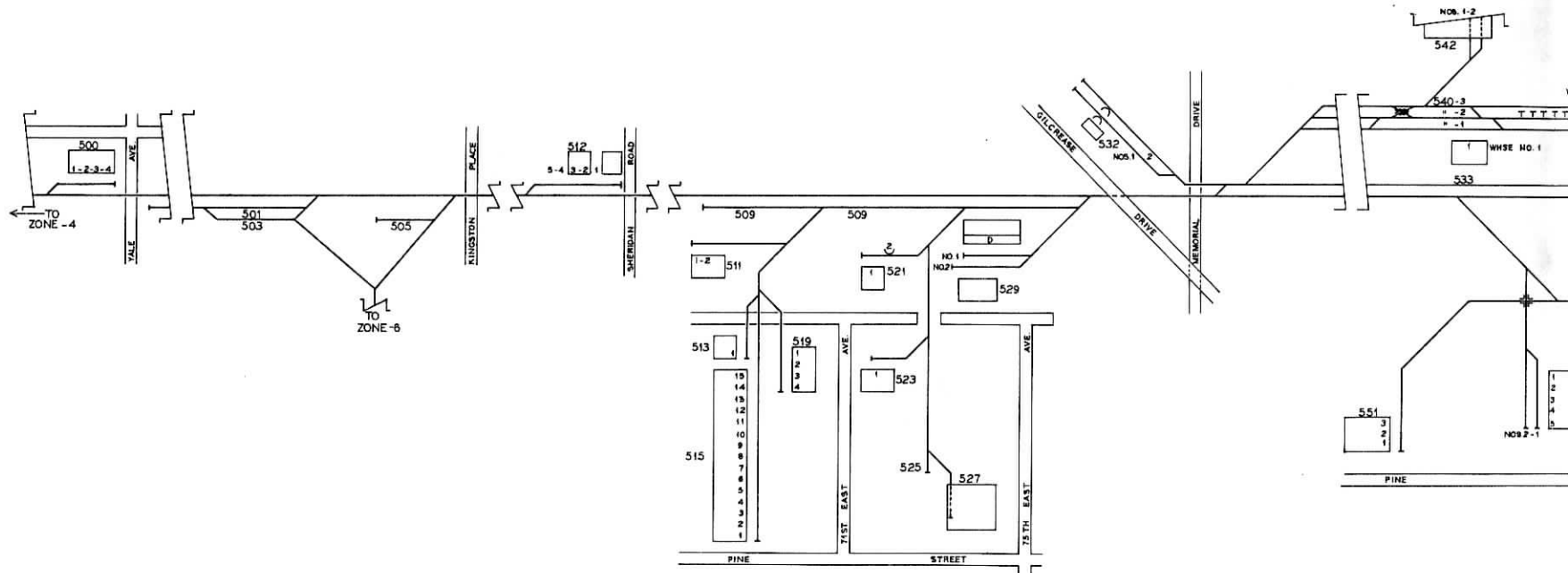

TULSA TERMINAL
 ZONE -5

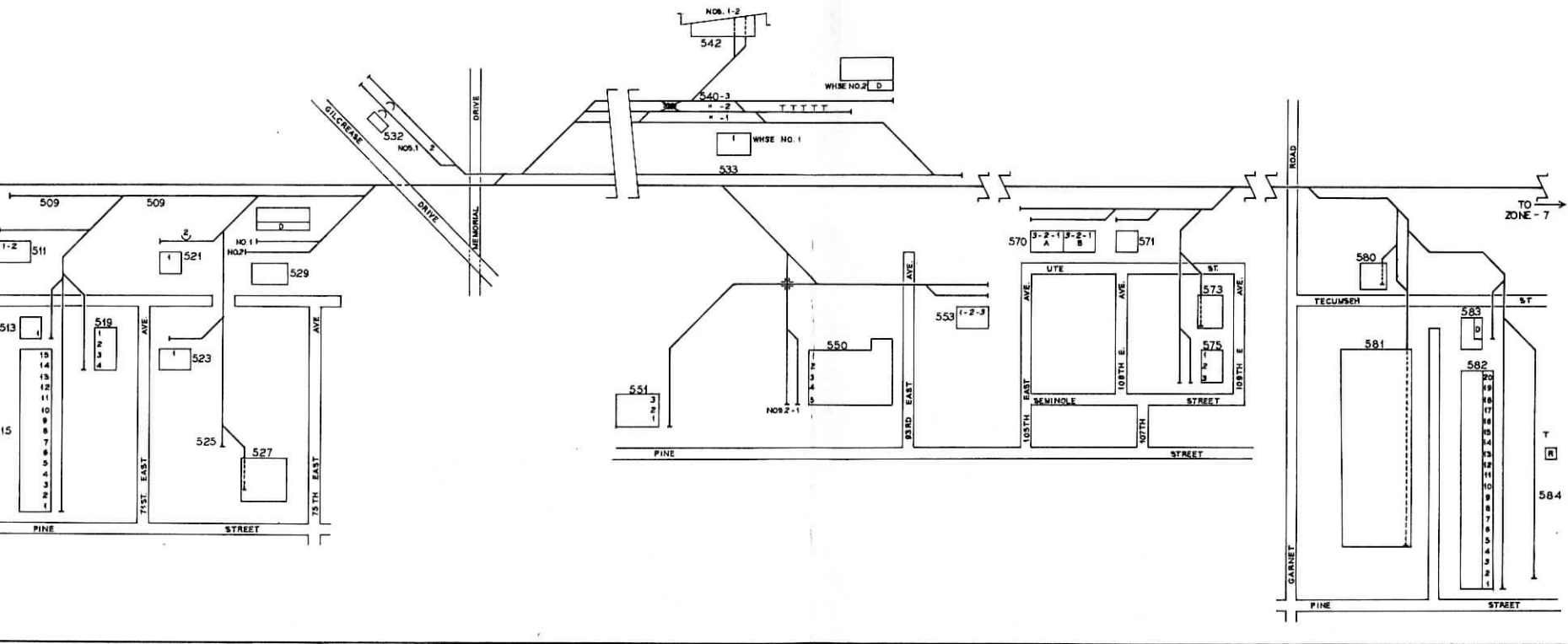

TULSA TERMINAL

ZONE 6

HOWARD BRANCH

ZONE 6 - HOWARD BRANCH

SPOT No.	INDUSTRY NAME
602	Hughes-Anderson Engineering Corporation
604	Dixon Concrete Products
608	Booster Feed Mills, Incorporated
609	Third Street runaround track
610	Admiral team track
616	Curtis Acoustics Company
618	Eleventh Street team track
622	Luttrell Oil Company
624	Downtown Warehouse Company
628	Chandler Materials Company No.2
629	Hanna Lumber Company
630	Tyler-Dawson Supply Company
632	Hope Lumber & Supply Company
633	Utility Supply Company
634	Anchor Paint Company
635	Petroleum Publishing Company
636	Tayloe Paper Company
637	Heatwave Supply Company, Incorporated
640	Champion Building Products
641	Oklahoma Natural Gas Company
642	H- Fifty-five team track
644	General Electric Company
645	Tulsa Pipe Coating Incorporated
646	Industrial Uniform & Towel Supply Incorporated
647	Best Warehouse Incorporated
648	Cam-Coors Incorporated
649	Tulsa N. O. Nelson Company
650	Mill Creek Lumber & Supply Company - Spot 1
654	Mill Creek Lumber & Supply Company - Spots 2 & 3
656	Public Service Company of Oklahoma
657	Mid-West Mill & Supply Company
658	Yale team track
660	Mill Creek Lumber & Supply Company - Spot 4
664	H- Sixty-two runaround track

TULSA TERMINAL
ZONE -6

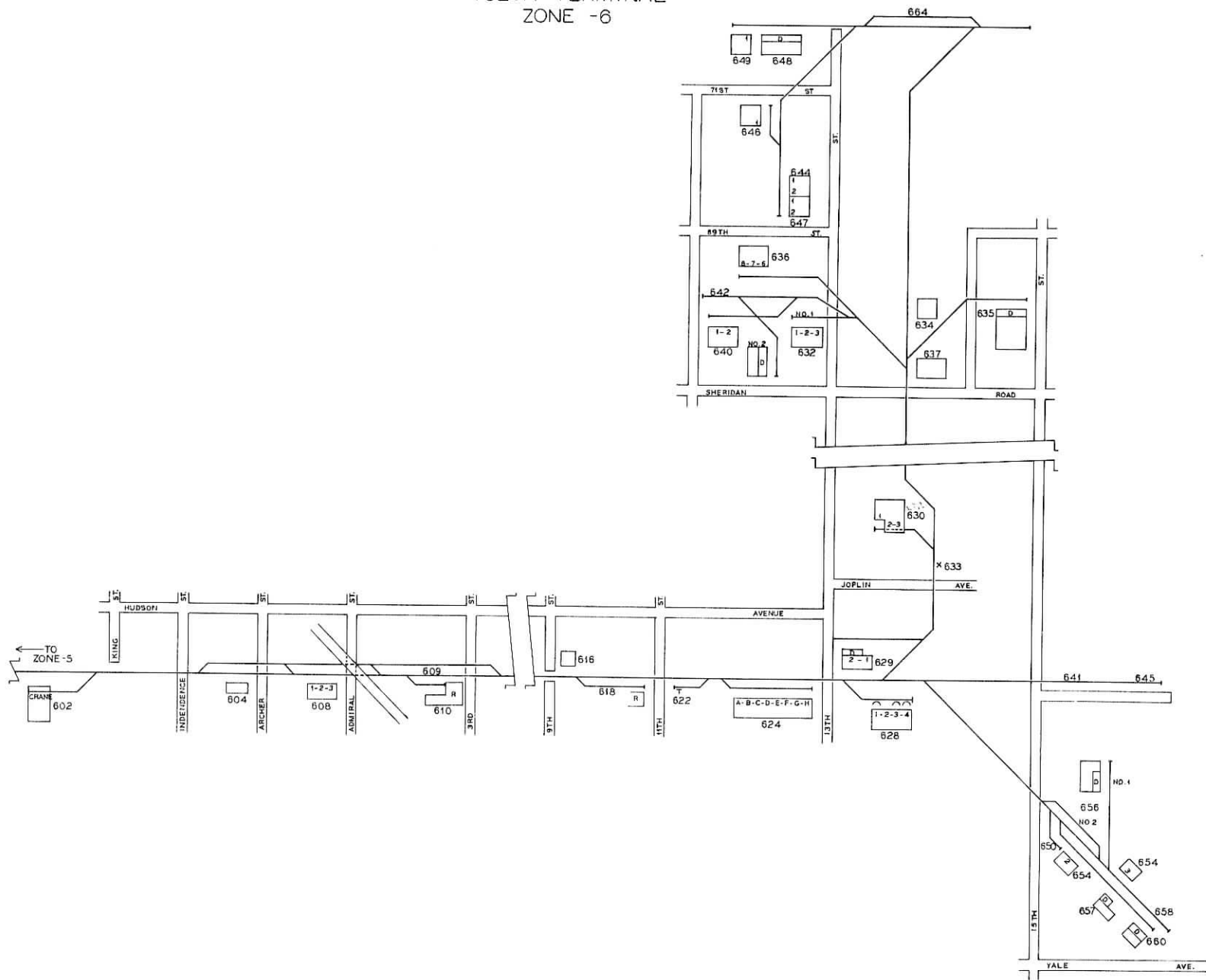

TULSA TERMINAL

ZONE 7

INDUSTRIES EAST of MINGO ROAD

ZONE 7 - INDUSTRIES EAST OF MINGO ROAD

<u>SPOT No.</u>	<u>INDUSTRY NAME</u>
710	Open
712	Chandler Materials Company No.3
714	Garnett team track
721	Standard Industries Incorporated
730	Garnett passing track
731	Martin-Marietta Corporation - Cement Western Division
732	Yuba Heat Transfer No.2 - Feedwater Heater Section
741	Tiger passing track
751	Universal Steel Corporation
753	Commercial Resins Company

TULSA TERMINAL
ZONE -7

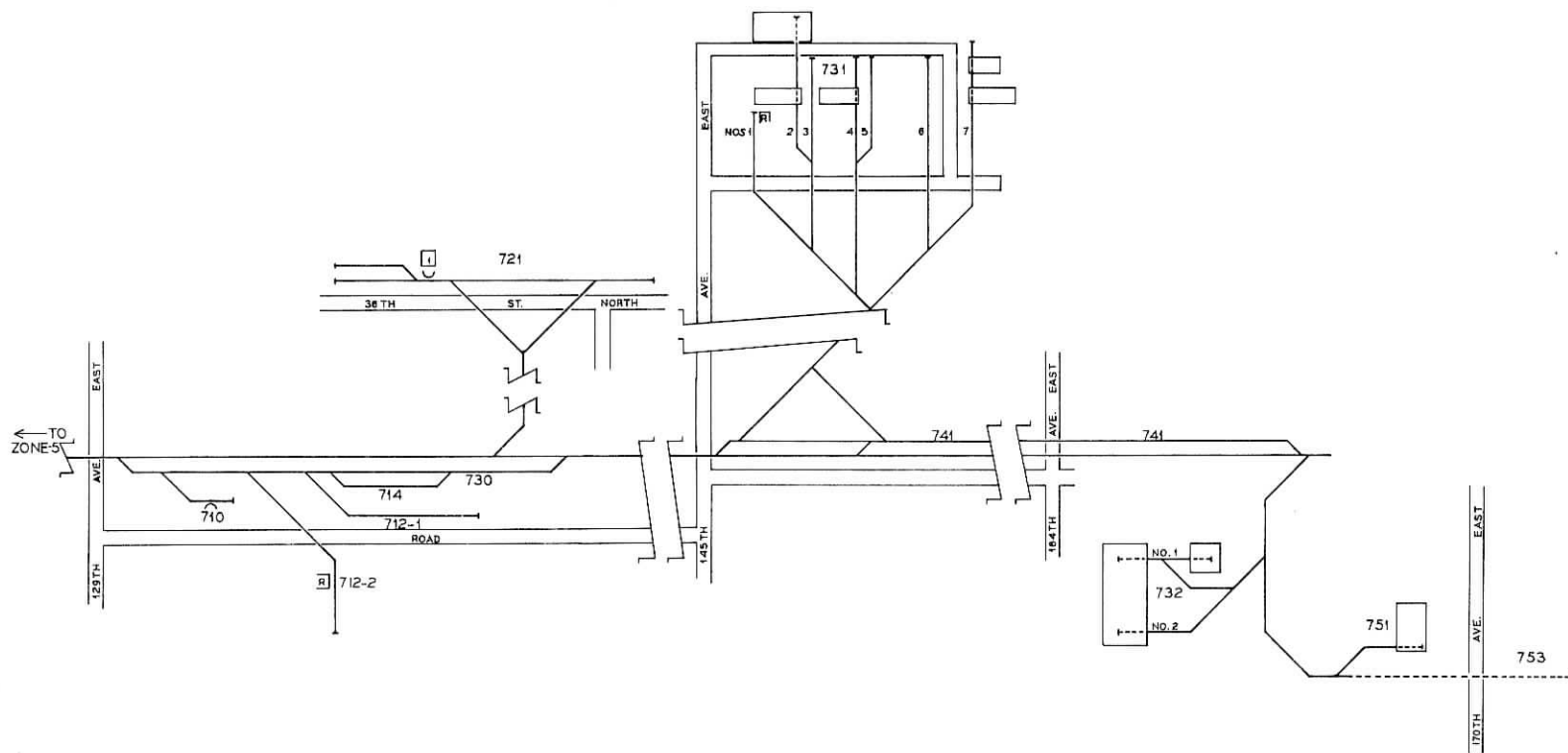

TULSA TERMINAL

ZONE 12

SUNRAY D-X OIL COMPANY

TULSA TERMINAL ZONE -12

